

Addison!

SPECIFICATIONS AND CONTRACT DOCUMENTS

FOR THE CONSTRUCTION OF

**BELT LINE ROAD UNDERGROUND
ELECTRICAL**

PHASE 1

**TOWN OF ADDISON, TEXAS
INFRASTRUCTURE OPERATIONS & SERVICES
RE-BID NUMBER 14-10**

MARCH 2014

PREPARED BY



**1201 North Bowser Road
Richardson, Texas 75081
(214) 346-6200**



M. E. Romanowski
3/21/14

Addison!

TOWN OF ADDISON, TEXAS

MAYOR

Todd Meier

COUNCILMEMBERS

Blake Clemens

Neil Resnik

Bruce Arfsten

Chris DeFransisco

Margie Gunther

Janelle Moore

CITY MANAGER

Lea Dunn

DIRECTOR OF INFRASTRUCTURE OPERATIONS AND SERVICES

Lisa Pyles

TABLE OF CONTENTS

Section AB	Advertisement for Bids
Section IB	Instructions to Bidders
Section PF	Proposal Form
Section BB	Bid Bond
Section CI	Indemnification Agreement (Void – provided in Special Provisions)
Section CA	Contract Agreement
Section PrB	Performance Bond
Section PyB	Payment Bond
Section MB	Maintenance Bond
Section BP	Contractor's Affidavit of Bills Paid
Section GP	General Provisions <i>Standard Specifications for Public Works Construction – North Central Texas</i>
Section SP	Special Provisions
Section PS	Project Sign
Section TS	Technical Specifications
Section IS	Additional Insurance Requirements, Town of Addison
Attachment	Geotechnical Investigation – 1/29/14

SECTION AB

ADVERTISEMENT FOR BIDS

ADVERTISEMENT FOR BIDS

1. The Town of Addison is requesting bids for Belt Line Road Underground Electrical Phase I – From Marsh Lane to Midway Road. Bids will be accepted until 2:00 p.m., April 17, 2014 at the Finance Building, 5350 Belt Line Rd., Addison, Texas 75001 – Attention Purchasing Department, at which time responders names and bids will be publicly read aloud. Late bids will not be considered. The plans, specifications, quantities, pre-bid time and date, and other information are available on www.bidsync.com. The plans, specifications, and quantities for the work to be done are also on file with Lisa A. Pyles, Director of Infrastructure Operations and Services, Town of Addison, 16801 Westgrove Drive, Addison, Texas 75001, and such plans, specifications, and quantities may be examined without charge. The Town of Addison reserves the right to waive any formalities, to reject any and all bids, and to select the proposal deemed most advantageous to the Town of Addison.
2. The Contractor shall identify his bid on the outside of the envelope by writing the words **INFRASTRUCTURE OPERATIONS & SERVICES RE-BID NUMBER 14-10, BELT LINE ROAD UNDERGROUND ELECTRICAL, PHASE 1 – FROM MARSH LANE TO MIDWAY ROAD.**

PAPER BIDS SHALL BE REQUIRED.

3. Bids shall be accompanied by a cashier's check or certified check upon a national or state bank in an amount not less than five percent (5%) of the total maximum bid price payable without recourse to the Town of Addison, or a bid bond in the same amount from a reliable surety company licensed by the State of Texas to act as a Surety and be listed on the current U.S. Treasury Listing of Approved Sureties, or a Binder of Insurance executed by a surety company licensed by the State of Texas to act as a surety or its authorized agent as a guarantee that the bidder will enter into a contract and execute a Performance Bond within ten (10) days after notice of award of contract to him.
4. Plans, specifications and bidding documents may be downloaded from www.bidsync.com. The Town of Addison is a "free buyer", meaning that prospective bidders need only a free registration to sign up for plan updates. Bidders assume all risk for acquiring specs and/or plans from third party sites and plan rooms, as only Bidsync.com will be directly updated by Addison.
5. The right is reserved by the Mayor and the City Council as the interests of the City may require to reject any or all bids and to waive any formality in bids received and to select the proposal deemed most advantageous to the City.
6. The Bidder (Proposer) must supply all the information required by the Proposal Form.
7. A Performance Bond, Labor and Material Payment Bond, and Maintenance Bond will be required by the Owner; each Bond shall be in the amount of 100% of the total contract amount. Bonds shall be issued by a surety company licensed by the State of Texas to act as a Surety and be listed on the current U.S. Treasury Listing of Approved Sureties.
8. For information on bidding, call Caitlan Smelly, Management Analyst and Procurement, Town of Addison, (972) 450-7087. For information on the work to be performed, call Lisa Pyles, Director of Infrastructure Operations & Services, Town of Addison, (972) 450-2878, or Mike Romanowski, P.E., Halff Associates, (214) 346-6270.

9. The project consists of Belt Line Road Underground Electrical Duct Banks and related improvements in accordance with the plans and specifications.
10. A **Pre-Bid Conference** will be held at **2:00 p.m. on Thursday, April 3, 2014** in the Large Conference Room of the Town of Addison Service Center, 16801 Westgrove Dr., Addison, Texas 75001, (972) 450-2871.

Advertise

March 28, 2014

SECTION IB

INSTRUCTIONS TO BIDDERS

INSTRUCTIONS TO BIDDERS

- A. PROJECT: BELT LINE ROAD**, in the Town of Addison. The bids will be evaluated as stated in Section "O" of these Instructions to Bidders.
- B. PROJECT DESCRIPTION:** The project consists of Construction of paving, grading, drainage, utilities, landscape and irrigation for Belt Line Road Underground Electrical – Phase 1, from Marsh to Midway.
- C. PROPOSALS:** Proposals must be in accordance with these instructions in order to receive consideration.
- D. DOCUMENTS:** Bidding Documents include the Project Manual (consisting of the Advertisement for Bids, these Instructions to Bidders, Proposal Forms, Contract Agreement, Performance Bond, Payment Bond, Maintenance Bond, Contractor's Affidavit of Bills Paid, General Provisions, Special Provisions, Project Sign, Technical Specifications, and Geotechnical Report), a Waiver of Lien, Drawings, and Addenda which may be issued by the Town of Addison during the bidding period. Bidding Documents may be viewed and/or obtained under the terms and conditions set forth in the Advertisement for Bids, Section AB of this Project Manual.
- E. EXAMINATION OF DOCUMENTS AND SITE:** Bidders shall carefully examine the Bidding Documents and the construction site to obtain firsthand knowledge of the scope and the conditions of the Work. Each Contractor, Subcontractor and Sub-subcontractor, by submitting a proposal to perform any portion of the Work, represents and warrants that he has examined the Drawings, Specifications (Project Manual) and the site of the Work, and from his own investigation has satisfied himself as to the scope, accessibility, nature and location of the Work; the character of the equipment and other facilities needed for the performance of the Work; the character and extent of other work to be performed; the local conditions; labor availability, practices and jurisdictions; and other circumstances that may affect the performance of the Work. No additional compensation will be allowed by the Owner for the failure of such Contractor, Subcontractor or Sub-subcontractor to inform himself as to conditions affecting the Work. **A Pre-Bid Conference will be held at 2:00 P.M. on Thursday, April 3, 2014** in the Large Conference Room of the Town of Addison Service Center, 16801 Westgrove Drive, Addison, Texas 75001, (972) 450-2871.
- F. INTERPRETATION OF DOCUMENTS:** If any person contemplating submitting a bid for the proposed Contract is in doubt as to the meaning of any part of the Drawings, Specifications (Project Manual) or other proposed Contract Documents, he may submit to the Town of Addison, not later than three (3) working days prior to the date set for opening bids, a written request for an interpretation or clarification. Bidders should act promptly and allow sufficient time for a reply to reach them before preparing their bids. Any interpretation or clarification will be in the form of an Addendum duly issued. No alleged verbal interpretation or ruling will be held binding upon the Owner.
- G. SUBSTITUTIONS:** Conditions governing the submission of substitutions for specific materials, products, equipment and processes are in the Special Provisions. Requests for

substitutions must be received by the Town of Addison seven (7) calendar days prior to the established bid date.

- H. ADDENDA:** Interpretations, clarifications, additions, deletions and modifications to the Documents during the bidding period will be issued in the form of Addenda and a copy of such Addenda will be released through www.bidsync.com. It will be the responsibility of each person who has been issued a set of bid documents to secure all Addenda from www.bidsync.com. Addenda will be a part of the Bidding Documents and the Contract Documents, and receipt of them shall be acknowledged in the Bid Form. All such interpretations and supplemental instructions will be in the form of written addenda to the contract documents which, if issued, will be released through www.bidsync.com not later than three (3) calendar days prior to the date fixed for the opening of bids. If any bidder fails to acknowledge the receipt of such addenda in the space provided in the bid form, his bid will nevertheless be construed as though the receipt of such addenda had been acknowledged.
- I. COMPLETION TIME:** The completion time of the project will be 15 Calendar Months.
- J. PREPARATION OF BIDS:** Prices quoted shall include all items of cost, expense, taxes, fees and charges incurred by, or arising out of, the performance of the work to be performed under the Contract. Bids shall be submitted in duplicate and shall be signed in ink. Any bid on other than the required form will be considered informal and may be rejected. Erasures or other changes in a bid must be explained or noted over the initials of the bidder. Bids containing any conditions, omissions, unexplained erasures and alterations, or irregularities of any kind may be rejected as informal. The prices should be expressed in words and figures or they may be deemed informal and may be rejected. In case of discrepancy between the price written in the bid and that given in the figures, the price in writing will be considered as the bid. In the case of a discrepancy between a unit price and its extension, the unit price will govern. Failure to submit all requested information will make a bid irregular and subject to rejection. Bids shall be signed with name typed or printed below signature, and, if a partnership, give full name of all partners. Where bidder is a corporation, bids must be signed with the legal name of the corporation followed by the name of the state of incorporation and the legal signature of an officer authorized to bind the corporation to a contract.

NOTE: AN ELECTRONIC SPREADSHEET IS POSTED ON BIDSYNC FOR CONTRACTORS CONVENIENCE TITLED BID SCHEDULE RE-BID 14-10.XLSX. THIS SPREADSHEET MAY BE USED IN LIEU OF THE MANUAL HANDWRITTEN PROPOSAL FORM IN THE SPECIFICATIONS AND SHALL BE ATTACHED TO THE PROPOSAL AND MADE PART OF THE CONTRACT DOCUMENTS. USING THE SPREADSHEET OPTION SHALL NOT AMEND OR MODIFY ANY WORDING IN THE PROPOSAL FORM OR THE PLANS AND THE CONTRACTOR SHALL BE RESPONSIBLE FOR CONFIRMING THAT THE SPREADSHEET ADEQUATELY CONVEYS THEIR BID.

SUBMITTAL OF BIDS: Sealed proposals will be received at the time, date and place stated in the Advertisement for Bids. Proposals shall be made on unaltered Proposal Forms furnished by the Town of Addison. Bidders shall submit proposals in an opaque, sealed envelope

addressed to the Owner and plainly mark on the outside of the envelope the name and address of the bidder. The envelopes shall also be marked with the following project description:

INFRASTRUCTURE OPERATIONS & SERVICES RE-BID NUMBER 14-10
BELT LINE ROAD UNDERGROUND ELECTRICAL – PHASE 1

The Bid Bond must be completed and signed by each bidder and submitted with the bid. Submit Bids by mail or in person prior to the time for receiving bids set forth in the Advertisement for Bids issued by the Town.

Electronic bidding on bidsync.com will not be considered for this project. The Town of Addison uses bidsync to distribute bids and proposals. There will be NO COST to the contractor for standard bids or proposals. Re-Bid number 14-10 is considered a standard bid. For Cooperative Bids and Reverse Auctions ONLY, the successful contractor/supplier agrees to pay bidsync a transaction fee of one percent (1%) of the total amount of all contracts for goods and/or services. Cooperative Bids and Reverse Auctions will be clearly marked on the bid documents. To assure that all contractors/suppliers are treated fairly, the fee will be payable whether the bid/proposal is submitted electronically, or by paper means. Refer to www.bidsync.com for further information.

- K. MODIFICATION AND WITHDRAWAL OF BIDS:** Prior to the time set for bid opening, bids may be withdrawn or modified. Bids may be modified only on the official bid form and must be signed by a person legally empowered to bind the bidder. No bidder shall modify, withdraw, or cancel his bid or any part thereof for sixty (60) calendar days after the time agreed upon for the receipt of bids.
- L. DISQUALIFICATION:** The Owner reserves the right to disqualify proposals, before or after the opening, upon evidence of collusion with intent to defraud or other illegal practices relating to this proposal upon the part of the bidder.
- M. SUBMISSION OF POST-BID INFORMATION:** Upon notification of acceptance, the selected bidder shall, within five (5) calendar days, submit the following:
1. A designation of the portions of the Work proposed to be performed by the bidder with his own force.
 2. A list of names of the Subcontractors or other persons or organizations, including those who are to furnish materials and equipment fabricated to a special design proposed for such portions of the Work as may be designated in the Bidding Documents or as may be requested by the Town of Addison. The bidder will be required to establish to the satisfaction of the Owner the reliability and responsibility of the proposed Subcontractors and suppliers to furnish and perform the Work.
 3. Other information as required.
- N. AWARD:** The Owner reserves the right to accept any or to reject any bids without compensation to bidders and to waive irregularities and informalities. The Town of Addison Infrastructure Operations & Services Department, in making its recommendation, will consider the following elements:

1. Whether the bidder is a contractor with experience in the type of work involved.
2. Whether the bidder has adequate plant, equipment and personnel to perform the work properly and expeditiously.
3. Whether the bidder has a suitable financial status and reputation for meeting obligations incident to work of the kind specified.
4. Whether the bidder has complied with the terms and conditions.

Alternate items may or may not be awarded. Addition or deletion of other items or schedules will be governed by the *Standard Specifications for Public Works Construction – North Central Texas, 4th Edition*, (hereinafter called SSPWC) Item 104.2 "Change or Modification of Contract".

- O. EXECUTION OF THE CONTRACT:** The successful bidder will be required to enter into a contract with the Owner within ten (10) days of notice by the Owner that his bid has been accepted. Failure to enter into a contract within the established time limit shall be considered grounds for forfeiture of the bid bond.
- P. CONSTRUCTION SCHEDULE:** It is the Owner's desire to have the project completed and operational in as short a time as possible. The number of calendar days for completion of the project will begin with the date specified in the Notice to Proceed. The Notice to Proceed will be issued in a manner to facilitate a smooth construction of the project. The Contractor shall begin construction within ten (10) calendar days of the issuance of the Notice to Proceed.
- Q. COST PLUS TIME BIDDING:** N/A
- R. FORM OF CONTRACT:** The contract for the construction of the project will be drawn up by the Owner. A sample form of agreement is included in the Contract Agreement Section.
- S. BONDS:** A Performance Bond, a Labor and Material Payment Bond and a Maintenance Bond will be required by the Owner. The Performance Bond and Payment Bond shall name the Town of Addison, and others as directed by the Town, as joint obligees. Sample forms have been included in the Performance Bond, Payment Bond, and Maintenance Bond sections. (Contractor shall confirm the legal names of obligees prior to execution of Bonds.)
- T. BID SECURITY:** Bids shall be accompanied by a cashier's check or certified check upon a national or state bank in an amount not less than five percent (5%) of the total maximum bid price payable without recourse to the Town of Addison, or a bid bond in the same amount from a surety company licensed to do business in the State of Texas as a guarantee that the bidder will enter into a contract and execute a Performance Bond and Payment Bond within ten (10) calendar days after notice of award of contract to him. Such checks or bid bonds will be returned to all except the three lowest bidders within three (3) days after the opening of bids, and the remaining checks or bid bonds will be returned promptly after the Owner has made an award of contract, or, if no award has been made within thirty (30) calendar days after the date of the opening of bids, upon demand of the bidder at any time thereafter, so long as he has not been notified of the acceptance of his bid.

- U. RESOLUTIONS:** If the bidder is a corporation, a copy of the resolution empowering the person submitting the bid to bind the bidder must be included with the bid.
- V. CONSTRUCTION STAKING:** Construction staking and re-staking will not be provided by the Owner. Benchmarks and Horizontal Control are shown on the plans. There is no separate bid item for staking, therefore, the contractor must include value for staking in the various bid items as subsidiary to the contract. Any staking or re-staking that is required shall be the responsibility of the Contractor and shall be at no cost to the Owner.
- W. FINAL PAYMENT:** The general provisions for Final Payment shall be as stated in Item 109.5.4 of the SSPWC including all Amendments and Additions. Prior to final payment the Contractor shall provide the Owner with the following items:
1. A Contractor's Affidavit of Bills Paid in accordance with Section BP.
 2. A Consent of Surety Company to Final Payment.
 3. A complete set of record plans which indicate all construction variations from the original construction documents in accordance with the Special Provisions.
 4. A two (2) year Maintenance Bond in accordance with Section MB.
 5. Acknowledgement that the project has been reviewed and accepted by TDLR.
- X. PREVAILING WAGE RATES:** Wage rates paid on this project shall not be less than specified in the schedule of general prevailing rates of per diem wages as attached in the Special Provisions.
- Y. PRIORITY OF CONTRACT DOCUMENTS:** In case of conflict between contract documents, priority of interpretation shall be in the following order: signed agreement; performance and payment bonds; proposal; special provisions (or conditions); technical specifications; general provisions; advertisement for bids; project drawings; *Standard Specifications for Construction and Maintenance of Highways, Streets, and Bridges* adopted by the Texas Department of Transportation June 1, 2004; Standard Specifications for Public Works Construction (NCTCOG, October 2004); Town of Addison Standard Drawings. This priority list shall take precedence over Item 105.1.1 of the SSPWC.

SECTION PF
PROPOSAL FORM

PROPOSAL FORM

_____, 2014

TO: The Honorable Mayor and Town Council
Town of Addison, Texas

Gentlemen:

The undersigned bidder, having examined the plans, specifications and contract documents, and the location of the proposed work, and being fully advised as to the extent and character of the work, proposes to furnish all equipment and to perform labor and work necessary for completion of the work described by and in accordance with the Plans, Specifications and Contract for the following prices, to wit:

Signed by: _____

ACKNOWLEDGMENT OF ADDENDA:

The Bidder acknowledges receipt of the following addenda:

Addendum No. 1 _____

Addendum No. 2 _____

Addendum No. 3 _____

The following pages contain all bid items for:

BID SCHEDULE – BELT LINE ROAD UNDERGROUND ELECTRICAL – PHASE 1

BID SCHEDULE

BELT LINE ROAD UNDERGROUND ELECTRICAL – PHASE 1

RE-BID NUMBER 14-10

Base Bid – Site Preparation and Miscellaneous

Item No.	Quantity	Unit	Description and Unit Price in Words	Unit Price in Figures	Total Amount
1.01	1	LS	Mobilization (no more than 5% of total bid) complete in place, the sum of _____ Dollars and _____ Cents per Unit.		
1.02	1	LS	Traffic Control complete in place, the sum of _____ Dollars and _____ Cents per Unit.		
1.03	1	LS	SW3P Including Maintenance, Inlet Protection and Erosion Control complete in place, the sum of _____ Dollars and _____ Cents per Unit.		
1.04	713	SY	Remove & Replace Median complete in place, the sum of _____ Dollars and _____ Cents per Unit.		
1.05	220	SY	Remove Existing Concrete Pavement complete in place, the sum of _____ Dollars and _____ Cents per Unit.		

Base Bid – Site Preparation and Miscellaneous

Item No.	Quantity	Unit	Description and Unit Price in Words	Unit Price in Figures	Total Amount
1.06	43,982	SF	Remove Existing Concrete Sidewalk complete in place, the sum of _____ _____ Dollars and _____ Cents per _____ Unit.		
1.07	2	EA	Project Signs complete in place, the sum of _____ _____ Dollars and _____ Cents per _____ Unit.		
1.08	5	EA	Remove and Relocate Light Poles complete in place, the sum of _____ _____ Dollars and _____ Cents per _____ Unit.		
Belt Line Road Site Preparation & Misc. Subtotal					

Base Bid – Paving and Sidewalks

Item No.	Quantity	Unit	Description and Unit Price in Words	Unit Price in Figures	Total Amount
2.01	0	TON	3/4" Novachip (95 lb/sy-in) complete in place, the sum of _____ Dollars and _____ Cents per Unit.		NOT USED
2.02	0	GAL	Asphalt Membrane (0.25 gal/sy) complete in place, the sum of _____ Dollars and _____ Cents per Unit.		NOT USED
2.03	0	SY	Milling complete in place, the sum of _____ Dollars and _____ Cents per Unit.		NOT USED
2.04	4,591	SY	Full Depth Repair complete in place, the sum of _____ Dollars and _____ Cents per Unit.		
2.05	13	EA	Median/Island Adjustment complete in place, the sum of _____ Dollars and _____ Cents per Unit.		
2.06	197	LF	Concrete Curb & Gutter complete in place, the sum of _____ Dollars and _____ Cents per Unit.		

Item No.	Quantity	Unit	Description and Unit Price in Words	Unit Price in Figures	Total Amount
2.07	1,170	LF	6" Concrete Edge complete in place, the sum of _____ Dollars and _____ Cents per Unit.		
2.08	44,687	SF	Concrete Sidewalk complete in place, the sum of _____ Dollars and _____ Cents per Unit.		
2.09	60	EA	Curb Ramp, - Directional, Non-Directional and Flared (including detectable warning plates) complete in place, the sum of _____ Dollars and _____ Cents per Unit.		
2.10	1	EA	Island Curb Ramp (including detectable warning plate) complete in place, the sum of _____ Dollars and _____ Cents per Unit.		
2.11	253	LF	Variable Height Sidewalk Wall complete in place, the sum of _____ Dollars and _____ Cents per Unit.		
2.12	275	LF	Variable Height Unit Paver Wall complete in place, the sum of _____ Dollars and _____ Cents per Unit.		

Item No.	Quantity	Unit	Description and Unit Price in Words	Unit Price in Figures	Total Amount
2.13	0	TON	Superpave Mixtures SP-D SAC-B PG70-22 (Rich Bottom Layer Asphalt Edge Repair) complete in place, the sum of _____ Dollars and _____ Cents per Unit.		NOT USED
Belt Line Road Paving and Sidewalks Subtotal					

Base Bid – Pavement Markings and Signs

Item No.	Quantity	Unit	Description and Unit Price in Words	Unit Price in Figures	Total Amount
3.01	0	EA	White Thermo Turn Arrow (125 mil. Thickness) complete in place, the sum of _____ _____ Dollars and _____ Cents per _____ Unit.		NOT USED
3.02	0	EA	White Thermo Lettering "ONLY" (125 mil. Thickness) complete in place, the sum of _____ _____ Dollars and _____ Cents per _____ Unit.		NOT USED
3.03	0	LF	4" Type I White Skip Thermo (90 mil. Thickness) complete in place, the sum of _____ _____ Dollars and _____ Cents per _____ Unit.		NOT USED
3.04	0	LF	4" Type I White Dot Thermo (90 mil. Thickness) complete in place, the sum of _____ _____ Dollars and _____ Cents per _____ Unit.		NOT USED
3.05	0	LF	4" Type I Yellow Solid Thermo (90 mil. Thickness) complete in place, the sum of _____ _____ Dollars and _____ Cents per _____ Unit.		NOT USED

Item No.	Quantity	Unit	Description and Unit Price in Words	Unit Price in Figures	Total Amount
3.06	0	LF	8" Type I White Solid Thermo (90 mil. Thickness) complete in place, the sum of _____ Dollars and _____ Cents per Unit.		NOT USED
3.07	0	LF	24" Type I White Thermo Stop Bar (125 mil. Thickness) complete in place, the sum of _____ Dollars and _____ Cents per Unit.		NOT USED
3.08	0	LF	12" Type I White Thermo Transverse Crosswalk (125 mil. Thickness) complete in place, the sum of _____ Dollars and _____ Cents per Unit.		NOT USED
3.09	0	LF	White Thermo Yield Line (125 mil. Thickness) complete in place, the sum of _____ Dollars and _____ Cents per Unit.		NOT USED
3.10	0	EA	Pavement Sealer (Arrow) complete in place, the sum of _____ Dollars and _____ Cents per Unit.		NOT USED
3.11	0	EA	Pavement Sealer (Word) complete in place, the sum of _____ Dollars and _____ Cents per Unit.		NOT USED

Item No.	Quantity	Unit	Description and Unit Price in Words	Unit Price in Figures	Total Amount
3.12	0	LF	Pavement Sealer 4" complete in place, the sum of _____ Dollars and _____ Cents per Unit.		NOT USED
3.13	0	LF	Pavement Sealer 8" complete in place, the sum of _____ Dollars and _____ Cents per Unit.		NOT USED
3.14	0	LF	Pavement Sealer 12" complete in place, the sum of _____ Dollars and _____ Cents per Unit.		NOT USED
3.15	0	LF	Pavement Sealer 24" complete in place, the sum of _____ Dollars and _____ Cents per Unit.		NOT USED
3.16	0	LF	Pavement Sealer Yield Line complete in place, the sum of _____ Dollars and _____ Cents per Unit.		NOT USED
3.17	0	EA	White R.P.M. Type II-C-R complete in place, the sum of _____ Dollars and _____ Cents per Unit.		NOT USED

Item No.	Quantity	Unit	Description and Unit Price in Words	Unit Price in Figures	Total Amount
3.18	0	EA	Yellow R.P.M Type II-A-A complete in place, the sum of _____ Dollars and _____ Cents per Unit.		NOT USED
3.19	0	EA	4"Round Non-Reflective Yellow Marker complete in place, the sum of _____ Dollars and _____ Cents per Unit.		NOT USED
3.20	10	EA	Small Aluminum Road Sign (includes mount) complete in place, the sum of _____ Dollars and _____ Cents per Unit.		
3.21	1	LS	Relocate Existing Signs complete in place, the sum of _____ Dollars and _____ Cents per Unit.		
3.22	0	EA	White RPM, Type 1-C Markers complete in place, the sum of _____ Dollars and _____ Cents per Unit.		NOT USED
Belt Line Road Pavement Markings & Signs Subtotal					

Base Bid – Drainage Improvements

Item No.	Quantity	Unit	Description and Unit Price in Words	Unit Price in Figures	Total Amount
4.01	119	LF	RC Pipe (CL III) (18 in) complete in place, the sum of _____ _____ Dollars and _____ Cents per Unit.		
4.02	70	LF	Trench Excavation Protection complete in place, the sum of _____ _____ Dollars and _____ Cents per Unit.		
4.03	1	EA	6' Standard Curb Inlet complete in place, the sum of _____ _____ Dollars and _____ Cents per Unit.		
4.04	7	EA	10' Recessed Curb Inlet complete in place, the sum of _____ _____ Dollars and _____ Cents per Unit.		
Belt Line Road Drainage Improvements Subtotal					

Base Bid – Water Improvements

Item No.	Quantity	Unit	Description and Unit Price in Words	Unit Price in Figures	Total Amount
5.01	128	LF	8" Water Line by Open Cut complete in place, the sum of _____ Dollars and _____ Cents per Unit.		
5.02	2	EA	8" Gate Valves complete in place, the sum of _____ Dollars and _____ Cents per Unit.		
5.03	0	EA	12" Gate Valves complete in place, the sum of _____ Dollars and _____ Cents per Unit.		NOT USED
5.04	0	LF	16" Steel Encasement pipe complete in place, the sum of _____ Dollars and _____ Cents per Unit.		NOT USED
5.05	3	EA	20" Butterfly Valve with 6" By-Pass and 6' Dia. Manhole complete in place, the sum of _____ Dollars and _____ Cents per Unit.		
5.06	2	EA	24" Butterfly Valve with 6" By-Pass and 6' Dia. Manhole complete in place, the sum of _____ Dollars and _____ Cents per Unit.		

Item No.	Quantity	Unit	Description and Unit Price in Words	Unit Price in Figures	Total Amount
5.07	80	LF	12" Sanitary Sewer Line by Open Cut complete in place, the sum of _____ Dollars and _____ Cents per Unit.		
5.08	208	LF	Trench Excavation Protection complete in place, the sum of _____ Dollars and _____ Cents per Unit.		
Belt Line Road Water Improvements Subtotal					

Base Bid – Oncor Duct Bank

Item No.	Quantity	Unit	Description and Unit Price in Words	Unit Price in Figures	Total Amount
6.01	142	LF	2E2 Duct Bank complete in place, the sum of _____ Dollars and _____ Cents per Unit.		
6.02	549	LF	2E4 Duct Bank complete in place, the sum of _____ Dollars and _____ Cents per Unit.		
6.03	76	LF	2E4-2E2 Duct Bank complete in place, the sum of _____ Dollars and _____ Cents per Unit.		
6.04	234	LF	4E4 Duct Bank complete in place, the sum of _____ Dollars and _____ Cents per Unit.		
6.05	65	LF	6E4 Duct Bank complete in place, the sum of _____ Dollars and _____ Cents per Unit.		
6.06	600	LF	2E6 Duct Bank complete in place, the sum of _____ Dollars and _____ Cents per Unit.		

Item No.	Quantity	Unit	Description and Unit Price in Words	Unit Price in Figures	Total Amount
6.07	54	LF	2E6-2E4 Duct Bank complete in place, the sum of _____ _____ Dollars and _____ Cents per Unit.		
6.08	1,294	LF	4E6 Duct Bank complete in place, the sum of _____ _____ Dollars and _____ Cents per Unit.		
6.09	45	LF	4E6-2E4 Duct Bank complete in place, the sum of _____ _____ Dollars and _____ Cents per Unit.		
6.10	20	LF	4E6-2E4-2E2 Duct Bank complete in place, the sum of _____ _____ Dollars and _____ Cents per Unit.		
6.11	85	LF	4E6-4E4 Duct Bank complete in place, the sum of _____ _____ Dollars and _____ Cents per Unit.		
6.12	32	LF	4E6-6E4 Duct Bank complete in place, the sum of _____ _____ Dollars and _____ Cents per Unit.		

Item No.	Quantity	Unit	Description and Unit Price in Words	Unit Price in Figures	Total Amount
6.13	107	LF	6E6 Duct Bank complete in place, the sum of _____ Dollars and _____ Cents per Unit.		
6.14	4,234	LF	8E6 Duct Bank complete in place, the sum of _____ Dollars and _____ Cents per Unit.		
6.15	684	LF	8E6-2E4 Duct Bank complete in place, the sum of _____ Dollars and _____ Cents per Unit.		
6.16	321	LF	8E6-4E4 Duct Bank complete in place, the sum of _____ Dollars and _____ Cents per Unit.		
6.17	50	LF	12E6 Duct Bank complete in place, the sum of _____ Dollars and _____ Cents per Unit.		
6.18	2	EA	3-Way Manhole complete in place, the sum of _____ Dollars and _____ Cents per Unit.		

Item No.	Quantity	Unit	Description and Unit Price in Words	Unit Price in Figures	Total Amount
6.19	23	EA	4-Way Manhole complete in place, the sum of _____ Dollars and _____ Cents per Unit.		
6.20	2	EA	Double stacked 4-Way Manhole complete in place, the sum of _____ Dollars and _____ Cents per Unit.		
6.21	167	LF	8E6 Duct Bank (BOTO) complete in place, the sum of _____ Dollars and _____ Cents per Unit.		
6.22	97	LF	8E6-2E4 Duct Bank (BOTO) complete in place, the sum of _____ Dollars and _____ Cents per Unit.		
6.23	0	EA	Vista Gear Pad (includes necessary duct bank bends & adjustments for connections) complete in place, the sum of _____ Dollars and _____ Cents per Unit.		NOT USED
6.24	0	EA	PME Pad (includes necessary duct bank bends & adjustments for connections) complete in place, the sum of _____ Dollars and _____ Cents per Unit.		NOT USED

Item No.	Quantity	Unit	Description and Unit Price in Words	Unit Price in Figures	Total Amount
6.25	0	EA	Transformer Pad (includes necessary duct bank bends & adjustments for connections) complete in place, the sum of _____ Dollars and _____ Cents per Unit.		NOT USED
6.26	61	LF	36" Steel Encasement Pipe with Spacers (for existing utility crossings) complete in place, the sum of _____ Dollars and _____ Cents per Unit.		
6.27	10	EA	Stainless Steel Cabinet (for Oncor provided meter) complete in place, the sum of _____ Dollars and _____ Cents per Unit.		
6.28	13	EA	Termination of Primary Conduit at Riser Pole complete in place, the sum of _____ Dollars and _____ Cents per Unit.		
6.29	29	EA	Three Phase Primary Subsurface Splice/Pull Box complete in place, the sum of _____ Dollars and _____ Cents per Unit.		

Item No.	Quantity	Unit	Description and Unit Price in Words	Unit Price in Figures	Total Amount
6.30	1	EA	Single Phase Primary Subsurface Splice/Pull Box complete in place, the sum of _____ _____ Dollars and _____ Cents per Unit.		
6.31	1	EA	Subsurface Secondary/Service Box complete in place, the sum of _____ _____ Dollars and _____ Cents per Unit.		
6.32	8,563	LF	Trench Excavation Protection complete in place, the sum of _____ _____ Dollars and _____ Cents per Unit.		
Belt Line Road Oncor Duct Bank Subtotal					

Base Bid – Traffic Signals

Item No.	Quantity	Unit	Description and Unit Price in Words	Unit Price in Figures	Total Amount
7.01	132	LF	Drill Shaft Traffic Signal Pole (48") complete in place, the sum of _____ Dollars and _____ Cents per Unit.		
7.02	52	LF	Drill Shaft Traffic Signal Pole (36") complete in place, the sum of _____ Dollars and _____ Cents per Unit.		
7.03	44	LF	Drill Shaft Traffic Signal Pole (30") complete in place, the sum of _____ Dollars and _____ Cents per Unit.		
7.04	178	LF	Conduit-2" Dia (Schd 40-Pvc) complete in place, the sum of _____ Dollars and _____ Cents per Unit.		
7.05	185	LF	Conduit-3" Dia (Schd 40-Pvc) complete in place, the sum of _____ Dollars and _____ Cents per Unit.		

Item No.	Quantity	Unit	Description and Unit Price in Words	Unit Price in Figures	Total Amount
7.06	203	LF	Conduit-4" Dia (Schd 40-Pvc) complete in place, the sum of _____ _____ Dollars and _____ Cents per Unit.		
7.07	1,192	LF	Conduit-4" Dia (Schd 40-Pvc) Bore complete in place, the sum of _____ _____ Dollars and _____ Cents per Unit.		
7.08	66	LF	Electric Conductor (No. 6 Bare) complete in place, the sum of _____ _____ Dollars and _____ Cents per Unit.		
7.09	128	LF	Electric Conductor (No. 6 Xhhw) complete in place, the sum of _____ _____ Dollars and _____ Cents per Unit.		
7.10	2,851	LF	Electric Conductor (No. 8 Bare) complete in place, the sum of _____ _____ Dollars and _____ Cents per Unit.		

Item No.	Quantity	Unit	Description and Unit Price in Words	Unit Price in Figures	Total Amount
7.11	3,200	LF	Tray Cable (ILSN) 3 Cndr #12 complete in place, the sum of _____ _____ Dollars and _____ Cents per Unit.		
7.12	17	EA	Ground Box, Type D complete in place, the sum of _____ _____ Dollars and _____ Cents per Unit.		
7.13	4	EA	Elc Srv Ty D 120/240 70 (Ns)Ss(E)Ps(U) complete in place, the sum of _____ _____ Dollars and _____ Cents per Unit.		
7.14	5	EA	Furnish & Install Traffic Signal Controller Foundation complete in place, the sum of _____ _____ Dollars and _____ Cents per Unit.		
7.15	5	EA	Relocate Existing Traffic Signal Controller And Cabinet complete in place, the sum of _____ _____ Dollars and _____ Cents per Unit.		

Item No.	Quantity	Unit	Description and Unit Price in Words	Unit Price in Figures	Total Amount
7.16	1	EA	Furnish & Install Traffic Signal Controller, Cabinet, and Foundation complete in place, the sum of _____ Dollars and _____ Cents per Unit.		
7.17	25	EA	Backplate (12" - 3 Section Head) complete in place, the sum of _____ Dollars and _____ Cents per Unit.		
7.18	12	EA	Backplate (12" - 4 Section Head) complete in place, the sum of _____ Dollars and _____ Cents per Unit.		
7.19	6	EA	Backplate (12" - HAWK Assembly Section Head) complete in place, the sum of _____ Dollars and _____ Cents per Unit.		
7.20	22	EA	Ped Sig Sec (12") Led (2 Indications) W/Countdown complete in place, the sum of _____ Dollars and _____ Cents per Unit.		

Item No.	Quantity	Unit	Description and Unit Price in Words	Unit Price in Figures	Total Amount
7.21	12	EA	Vehicle Signal Section (12" - Led Green/Yellow Bi-Model Arrow) complete in place, the sum of _____ Dollars and _____ Cents per Unit.		
7.22	37	EA	Vehicle Signal Section (12" - Led Green) complete in place, the sum of _____ Dollars and _____ Cents per Unit.		
7.23	43	EA	Vehicle Signal Section (12" - Led Yellow) complete in place, the sum of _____ Dollars and _____ Cents per Unit.		
7.24	49	EA	Vehicle Signal Section (12" - Led Red) complete in place, the sum of _____ Dollars and _____ Cents per Unit.		
7.25	2,932	LF	Traffic Signal Cable - Type A (20 Cond-14 Awg) complete in place, the sum of _____ Dollars and _____ Cents per Unit.		

Item No.	Quantity	Unit	Description and Unit Price in Words	Unit Price in Figures	Total Amount
7.26	1,580	LF	Traffic Signal Cable - Type A (7 Cond-14 Awg) complete in place, the sum of _____ _____ Dollars and _____ Cents per Unit.		
7.27	2,665	LF	Traffic Signal Cable - Type A (5 Cond-14 Awg) complete in place, the sum of _____ _____ Dollars and _____ Cents per Unit.		
7.28	267	LF	Traffic Signal Cable - Type A (2 Cond-14 Awg) complete in place, the sum of _____ _____ Dollars and _____ Cents per Unit.		
7.29	1	EA	Traffic Signal Pole, Mast Arm Assembly With ILSN (24 Ft) complete in place, the sum of _____ _____ Dollars and _____ Cents per Unit.		

Item No.	Quantity	Unit	Description and Unit Price in Words	Unit Price in Figures	Total Amount
7.30	3	EA	Traffic Signal Pole, Mast Arm Assembly With ILSN (28 Ft) complete in place, the sum of _____ _____ Dollars and _____ Cents per Unit.		
7.31	2	EA	Traffic Signal Pole, Mast Arm Assembly With ILSN (36 Ft) complete in place, the sum of _____ _____ Dollars and _____ Cents per Unit.		
7.32	1	EA	Traffic Signal Pole, Mast Arm Assembly With ILSN (40 Ft) complete in place, the sum of _____ _____ Dollars and _____ Cents per Unit.		
7.33	1	EA	Traffic Signal Pole, Mast Arm Assembly With ILSN (48 Ft) complete in place, the sum of _____ _____ Dollars and _____ Cents per Unit.		

Item No.	Quantity	Unit	Description and Unit Price in Words	Unit Price in Figures	Total Amount
7.34	5	EA	Traffic Signal Pole, Mast Arm Assembly With ILSN (55 Ft) complete in place, the sum of _____ _____ Dollars and _____ Cents per Unit.		
7.35	1	EA	Traffic Signal Pole, Mast Arm Assembly With ILSN (60 Ft) complete in place, the sum of _____ _____ Dollars and _____ Cents per Unit.		
7.36	22	EA	Ped Detect (2" Push Button) complete in place, the sum of _____ _____ Dollars and _____ Cents per Unit.		
7.37	3	EA	Vivds Processor System complete in place, the sum of _____ _____ Dollars and _____ Cents per Unit.		
7.38	12	EA	Vivds Camera Assembly (includes cable) complete in place, the sum of _____ _____ Dollars and _____ Cents per Unit.		

Item No.	Quantity	Unit	Description and Unit Price in Words	Unit Price in Figures	Total Amount
7.39	3	EA	Vivds Setup System complete in place, the sum of _____ Dollars and _____ Cents per Unit.		
7.40	3	EA	Salvage Traffic Signals per Intersection complete in place, the sum of _____ Dollars and _____ Cents per Unit.		
7.41	3,417	LF	Opticom Cable (12 Sensors) complete in place, the sum of _____ Dollars and _____ Cents per Unit.		
7.42	1,611	LF	Vivds Communication Cable complete in place, the sum of _____ Dollars and _____ Cents per Unit.		
7.43	26	EA	Aluminum Sign (Mast Arm Mount) complete in place, the sum of _____ Dollars and _____ Cents per Unit.		
Belt Line Road Traffic Signal Subtotal					

Base Bid – Hardscape

Item No.	Quantity	Unit	Description and Unit Price in Words	Unit Price in Figures	Total Amount
8.01	4,570	SF	Standard Grey Concrete w/ W.R. Grace #35 Beige Acid Etch Finish (4" Thick) complete in place, the sum of _____ _____ Dollars and _____ Cents per Unit.		
8.02	3,570	SF	Decorative Pavers complete in place, the sum of _____ _____ Dollars and _____ Cents per Unit.		
8.03	72	EA	24" x 36" Detectable Warning Plates (polymer concrete) complete in place, the sum of _____ _____ Dollars and _____ Cents per Unit.		
Belt Line Road Hardscape Subtotal					

Base Bid - Landscape and Irrigation

Item No.	Quantity	Unit	Description and Unit Price in Words	Unit Price in Figures	Total Amount
9.01	2,093	CY	6" Topsoil Import for Turf Area complete in place, the sum of <hr style="width: 80%; margin: 5px 0;"/> Dollars and <hr style="width: 80%; margin: 5px 0;"/> Cents per Unit.		
9.02	113,000	SF	Soil Prep Material and Landscape Grading complete in place, the sum of <hr style="width: 80%; margin: 5px 0;"/> Dollars and <hr style="width: 80%; margin: 5px 0;"/> Cents per Unit.		
9.03	113,000	SF	Common Bermuda 'Mid Iron' Sod complete in place, the sum of <hr style="width: 80%; margin: 5px 0;"/> Dollars and <hr style="width: 80%; margin: 5px 0;"/> Cents per Unit.		
9.04	113,000	SF	Turf Spray Irrigation repair complete in place, the sum of <hr style="width: 80%; margin: 5px 0;"/> Dollars and <hr style="width: 80%; margin: 5px 0;"/> Cents per Unit.		
9.05	104	EA	Tree Demolition complete in place, the sum of <hr style="width: 80%; margin: 5px 0;"/> Dollars and <hr style="width: 80%; margin: 5px 0;"/> Cents per Unit.		

Item No.	Quantity	Unit	Description and Unit Price in Words	Unit Price in Figures	Total Amount
9.06	1	LS	90 Day Establishment Period complete in place, the sum of _____ _____ Dollars and _____ Cents per _____ Unit.		
9.07	1	LS	1 Year Maintenance complete in place, the sum of _____ _____ Dollars and _____ Cents per _____ Unit.		
9.08	0	SF	Median Repair: Shrubs, Irrigation, Prep, Mulch and Trees (remove & repair to original state) complete in place, the sum of _____ _____ Dollars and _____ Cents per _____ Unit.		NOT USED
Belt Line Road Landscape and Irrigation Subtotal					

Base Bid - Telecom

Item No.	Quantity	Unit	Description and Unit Price in Words	Unit Price in Figures	Total Amount
10.01	26	EA	AT&T Handhole complete in place, the sum of _____ _____ Dollars and _____ Cents per Unit.		
10.02	31	EA	TWC Manhole complete in place, the sum of _____ _____ Dollars and _____ Cents per Unit.		
10.03	6	EA	TWC Vault/pedestal complete in place, the sum of _____ _____ Dollars and _____ Cents per Unit.		
10.04	4	EA	FiberLight Handhole complete in place, the sum of _____ _____ Dollars and _____ Cents per Unit.		
10.05	1,151	LF	2C4 Duct Bank complete in place, the sum of _____ _____ Dollars and _____ Cents per Unit.		

Item No.	Quantity	Unit	Description and Unit Price in Words	Unit Price in Figures	Total Amount
10.06	2,944	LF	4C4 Duct Bank complete in place, the sum of _____ _____ Dollars and _____ Cents per Unit.		
10.07	472	LF	4C4/2E4 Duct Bank complete in place, the sum of _____ _____ Dollars and _____ Cents per Unit.		
10.08	3,547	LF	6C4 Duct Bank complete in place, the sum of _____ _____ Dollars and _____ Cents per Unit.		
10.09	390	LF	6C4 Duct Bank (B.O.T.O.C.) complete in place, the sum of _____ _____ Dollars and _____ Cents per Unit.		

Item No.	Quantity	Unit	Description and Unit Price in Words	Unit Price in Figures	Total Amount
10.10	182	LF	6C4/2C3 Duct Bank complete in place, the sum of _____ _____ Dollars and _____ Cents per Unit.		
10.11	60	LF	6C4/2E2 Duct Bank complete in place, the sum of _____ _____ Dollars and _____ Cents per Unit.		
10.12	1054	LF	6C4/2E4 Duct Bank complete in place, the sum of _____ _____ Dollars and _____ Cents per Unit.		
10.13	395	LF	6C4/4E4 Duct Bank complete in place, the sum of _____ _____ Dollars and _____ Cents per Unit.		
10.14	126	LF	6C4/6E4 Duct Bank complete in place, the sum of _____ _____ Dollars and _____ Cents per Unit.		

Item No.	Quantity	Unit	Description and Unit Price in Words	Unit Price in Figures	Total Amount
10.15	2,288	LF	8C4 Duct Bank complete in place, the sum of _____ _____ Dollars and _____ Cents per _____ Unit.		
10.16	452	LF	8C4/2E2 Duct Bank complete in place, the sum of _____ _____ Dollars and _____ Cents per _____ Unit.		
10.17	50	LF	8C4/2C3/2E4 Duct Bank complete in place, the sum of _____ _____ Dollars and _____ Cents per _____ Unit.		
10.18	195	LF	8C4/2E4 Duct Bank complete in place, the sum of _____ _____ Dollars and _____ Cents per _____ Unit.		
10.19	182	LF	8C4/4E4 Duct Bank complete in place, the sum of _____ _____ Dollars and _____ Cents per _____ Unit.		

Item No.	Quantity	Unit	Description and Unit Price in Words	Unit Price in Figures	Total Amount
10.20	75	Lf	10C4 Duct Bank complete in place, the sum of _____ _____ Dollars and _____ Cents per _____ Unit.		
10.21	10	EA	Install Riser on existing power pole complete in place, the sum of _____ _____ Dollars and _____ Cents per _____ Unit.		
10.22	8	EA	Connect to existing underground line complete in place, the sum of _____ _____ Dollars and _____ Cents per _____ Unit.		
10.23	1	LS	Utility Adjustment Allowance complete in place, the sum of _____ _____ Dollars and _____ Cents per _____ Unit.	\$100,000.00	\$100,000.00
Belt Line Road Telecom Subtotal					

Add/Alternate Bid Items

Item No.	Quantity	Unit	Description and Unit Price in Words	Unit Price in Figures	Total Amount
11.01	1	EA	Tree Transplant complete in place, the sum of _____ Dollars and _____ Cents per Unit.		
11.02	4	EA	Yaupon Holly (10'-12' ht.) (Max 3-5 canes) complete in place, the sum of _____ Dollars and _____ Cents per Unit.		
11.03	1	EA	Bald Cypress (4" caliper) complete in place, the sum of _____ Dollars and _____ Cents per Unit.		
11.04	3	EA	Live Oak (4" caliper) complete in place, the sum of _____ Dollars and _____ Cents per Unit.		
11.05	13	EA	Red Oak (4" caliper) complete in place, the sum of _____ Dollars and _____ Cents per Unit.		

Item No.	Quantity	Unit	Description and Unit Price in Words	Unit Price in Figures	Total Amount
11.06	2	EA	Red Oak (8" caliper) complete in place, the sum of _____ _____ Dollars and _____ Cents per _____ Unit.		
Belt Line Road Add/Alternate Bid Items Subtotal					

SUMMARY

**BID SCHEDULE – BELT LINE ROAD UNDERGROUND ELECTRICAL –
PHASE 1**

- 1. Removal, Site Preparation and Miscellaneous Subtotal..... _____
 - 2. Paving and Sidewalks Subtotal..... _____
 - 3. Pavement Markings and Signs Subtotal..... _____
 - 4. Drainage Improvements Subtotal..... _____
 - 5. Water Improvements Subtotal..... _____
 - 6. ONCOR Duct Bank Subtotal..... _____
 - 7. Signal Improvements Subtotal..... _____
 - 8. Hardscape Improvements/Enhanced Subtotal..... _____
 - 9. Landscape Improvements Subtotal..... _____
 - 10. Telecom Duct bank (AT&T, TWC and Fiberlight Subtotal... _____
- TOTAL BID** _____

Written in Words: _____

- 11. Add/Alternate Bid Items Subtotal..... _____

The pay items included in this proposal form comprise all of the pay items for the project. Any additional required work shall be considered subsidiary to the related pay items provided herein.

- NOTES: 1. All items, labor, materials, equipment, facilities, incidentals and work required for construction of the project are to be provided and installed by the Contractor as part of the project and payment for the cost of such shall be included in the price bid for the construction of the project.
2. Prices must be shown in words and figures for each item listed in the Proposal. In the event of discrepancy, the words shall control.
3. Materials, which are "tax exempt", are those items which are physically incorporated into the facilities constructed for the Town of Addison, as set forth in the Special Provisions. Materials include, but are not limited to purchased items such as water pipe, sanitary sewer pipe, storm drain pipe, etc.

Services, which are "not tax exempt", are those items which are used by the Contractor but are not physically incorporated into the Town of Addison's facility and/or items which are consumed by construction, as set forth in the Special Provisions. Services include, but are not limited to, items such as supplies, tools, skill and labor, the purchase, rental or lease of equipment, etc.

Name of Person Signing Bid

Signature of Person Signing Bid

Address

Telephone No.

Fax No.

T.I.N. (Tax Identification or Employer's Number)

If BIDDER is:

AN INDIVIDUAL

By _____
(Individual's Name)

(Seal)

doing business as _____

Business address: _____

Phone No. _____

A PARTNERSHIP

By _____
(Firm Name)

(Seal)

(General Partner)

doing business as _____

Business address: _____

Phone No. _____

A CORPORATION

By _____
(Corporation Name)

(State of Incorporation)

By _____
(Name of Person Authorized to Sign)

(Title)

(Corporate Seal)

Attest _____
(Secretary)

Business address: _____

Phone No. _____

A JOINT VENTURE

By _____
(Name)

(Address)

By _____
(Name)

(Address)

(Each joint venture must sign. The manner of signing for each individual, partnership and corporation that is a party to the joint venture should be in the manner indicated above.)

SECTION BB
BID BOND

BID BOND

Bidder shall submit a bid bond equal to five percent (5%) of the bid price. Failure to submit a bid bond when required may deem the bid non-responsive. Bid Bonds may be submitted electronically with the executed original provided immediately upon request.

SECTION CI
INDEMNIFICATION AGREEMENT

SEE SECTION SP

SECTION CA

CONTRACT AGREEMENT

CONTRACT AGREEMENT

STATE OF TEXAS

COUNTY OF DALLAS

THIS AGREEMENT is made and entered into this _____ day of _____, 2014, by and between the Town of Addison, of the County of Dallas and State of Texas, acting through its City Manager, thereunto duly authorized so to do, Party of the First Part, hereinafter termed the OWNER, and _____, of the City of _____, County of _____, State of _____, Party of the Second Part, hereinafter termed CONTRACTOR.

WITNESSETH: That for and in consideration of the payment and agreement hereinafter mentioned, to be made and performed by the OWNER, the said CONTRACTOR hereby agrees with the said OWNER to commence and complete construction of certain improvements as follows:

BELT LINE ROAD UNDERGROUND ELECTRICAL – PHASE 1

INFRASTRUCTURE OPERATIONS & SERVICES RE-BID NUMBER 14-10

and all extra work in connection therewith, under the terms as stated in the General and Specific Conditions of the AGREEMENT; and at his own proper cost and expense to furnish all the materials, supplies, machinery, equipment, tools, superintendence, labor, insurance and other accessories and services necessary to complete the said construction, in accordance with the conditions and prices stated in the Proposal attached hereto and in accordance with the Advertisement for Bids, Instructions to Bidders, General Provisions, Special Provisions, Plans, and other drawings and printed or written explanatory matter thereof, and the Technical Specifications and Addenda thereto, as prepared by the OWNER, each of which has been identified by the endorsement of the CONTRACTOR and the OWNER thereon, together with the CONTRACTOR's written Proposal and the General Provisions, all of which are made a part hereof and collectively evidence and constitute the entire AGREEMENT.

The CONTRACTOR hereby agrees to commence work within ten (10) calendar days after the date of written notice to do so shall have been given to him, to complete the work within _____ (____) calendar days, after he commences work, subject to such extensions of time as are provided by the General Provisions.

The OWNER agrees to pay the CONTRACTOR _____ Dollars (\$ _____) in current funds for the performance of the Contract in accordance with the Proposal submitted thereof, subject to additions and deductions, as provided in the General Provisions, and to make payments of account thereof as provided therein.

IN WITNESS WHEREOF, the parties of these presents have executed this AGREEMENT in the year and day first above written.

TOWN OF ADDISON, TEXAS (OWNER)

ATTEST:

By: _____
Lea Dunn, City Manager

By: _____

(CONTRACTOR)

ATTEST:

By: _____

By: _____

The following to be executed if the CONTRACTOR is a corporation:

I, _____ certify that I am the secretary of the corporation named as CONTRACTOR herein; that _____, who signed this Contract on behalf of the CONTRACTOR is the _____ (official title) of said corporation; that said Contract was duly signed for and in behalf of said corporation by authority of its governing body, and is within the scope of its corporate powers.

Signed: _____

Corporate Seal

SECTION PrB
PERFORMANCE BOND

PERFORMANCE BOND

STATE OF TEXAS }
COUNTY OF DALLAS }

WHEREAS, _____ as principal ("Contractor") and _____ a corporation organized under the laws of _____ and being duly authorized to do business in the State of Texas, as surety ("Surety")(whether one or more), do hereby expressly acknowledge themselves to be held and bound to pay to the Town of Addison, Texas, a home-rule municipality organized and operating under the Constitution and laws of the State of Texas (the "Town"), its successors and assigns, and to all persons, firms, subcontractors and corporations who may furnish materials or labor under the contract as more fully described below, the sum of _____ Dollars in the lawful currency of the United States of America (\$) for the payment of which Contractor and Surety are liable to the Town, jointly and severally; and

WHEREAS, Contractor has this day entered into a written contract with the Town to build and construct _____

which contract and the plans and specifications therein mentioned (collectively referred to hereinafter as the "Contract") are hereby expressly incorporated into and made a part hereof as though set forth at length; and

WHEREAS, this bond is given pursuant to Chapter 2253 of the Texas Government Code;

NOW, THEREFORE, if Contractor shall well, truly and faithfully perform all of the undertakings, duties, terms, conditions and agreements of the Contract; shall satisfy all claims and demands incurred under the Contract; shall fully indemnify and hold the Town harmless; shall reimburse and repay the Town for any outlay or expense which the Town may incur in making good any default, and shall promptly make payment to all persons, firms, subcontractors and corporations who may furnish materials or labor under the Contract, then this obligation shall be void; otherwise to remain in full force and effect. The obligations of Contractor and Surety under this bond apply both to the original Contract and to any extension or modification of the Contract and Surety agrees that no change, extension of time, addition, expansion or other modification of the Contract, the work to be done under the Contract, or the plans and specifications which are a part of the Contract shall in any manner affect the obligations of Surety under this bond, and Surety waives notice of any such change, extension of time, addition, expansion or other modification. The obligations of Contractor and Surety under this bond are performable and payable in Dallas County, Texas such that exclusive venue for any legal action pertaining to this bond shall lie in Dallas County, Texas. By their signatures below, the persons signing this bond warrant and represent that they are, respectively, duly authorized to sign on behalf of Contractor and Surety.

EXECUTED this the ____ day of _____, 2_____.

CONTRACTOR:

SURETY: 1

By: _____

By: _____

Title: _____

Title: _____

ACKNOWLEDGMENTS
[Contractor]

STATE OF TEXAS }
COUNTY OF DALLAS }

Before me _____ (insert the name of the officer) on this day _____ personally appeared _____ known to me (or proved to me on the oath of _____) or through _____ (description of identity card or other document) to be the person whose name is subscribed to the forgoing instrument and acknowledged to me that he/she executed the same for the purpose and consideration therein expressed.

Given under my hand and seal of office this _____ day of _____, 2_____.

Notary Public in and for the State of Texas
My Commission Expires: _____

Typed or Printed Name of Notary

[Surety]

STATE OF TEXAS }
COUNTY OF DALLAS }

This instrument was acknowledged before me on the ____ day of _____, 2_____ by _____ who is the _____ of the Surety, on behalf of Surety.

GIVEN UNDER MY HAND AND SEAL OF OFFICE this the ____ day of _____, 2_____.

Notary Public in and for the State of Texas
My Commission Expires: _____

Typed or Printed Name of Notary

1 Please see attached contact sheet for Surety and the Texas Department of Insurance.

Payment and Performance Bond Contact Sheet

(1) Claims:

All notices of claims shall be sent to the surety at the following address:

(Name of surety)

(Mailing address)

(Physical address)

(Phone number)

(2) Texas Department of Insurance Contact Number:

The address and contact information of the surety may otherwise be obtained by contacting the Texas Department of Insurance at the following toll free telephone number:

1-800-252-3439.

SECTION PyB
PAYMENT BOND

PAYMENT BOND

STATE OF TEXAS }
COUNTY OF DALLAS }

WHEREAS, _____, as principal ("Contractor") and _____, a corporation organized under the laws of _____ and being duly authorized to do business in the State of Texas, as surety ("Surety")(whether one or more), do hereby expressly acknowledge themselves to be held and bound to pay to the Town of Addison, Texas, a home-rule municipality organized and operating under the Constitution and laws of the State of Texas (the "Town"), its successors and assigns, and to all persons, firms, subcontractors and corporations who may furnish materials or labor under the contract as more fully described below, the sum of _____ Dollars in the lawful currency of the United States of America (\$) for the payment of which Contractor and Surety are liable to the Town, jointly and severally; and

WHEREAS, Contractor has this day entered into a written contract with the Town to build and construct _____

which contract and the plans and specifications therein mentioned (collectively referred to hereinafter as the "Contract") are hereby expressly incorporated into and made a part hereof as though set forth at length; and

WHEREAS, this bond is given pursuant to Chapter 2253 of the Texas Government Code;

NOW, THEREFORE, if Contractor shall promptly make payment to all persons, firms, subcontractors and corporations who may furnish materials or labor under the Contract, then this obligation shall be void; otherwise to remain in full force and effect. The obligations of Contractor and Surety under this bond apply both to the original Contract and to any extension of time or modification of the Contract and Surety agrees that no change, extension of time, addition, expansion or other modification of the Contract, the work to be done under the Contract, or the plans and specifications which are a part of the Contract shall in any manner affect the obligations of Surety under this bond, and Surety waives notice of any such change, extension of time, addition, expansion or other modification. The obligations of Contractor and Surety under this bond are performable and payable in Dallas County, Texas such that exclusive venue for any legal action pertaining to this bond shall lie in Dallas County, Texas. By their signatures below, the persons signing this bond warrant and represent that they are, respectively, duly authorized to sign on behalf of Contractor and Surety.

EXECUTED this the _____ day of _____, 2_____.

CONTRACTOR: _____ SURETY: 1
By: _____ By: _____
Title: _____ Title: _____

ACKNOWLEDGMENTS
[Contractor]

STATE OF TEXAS }
COUNTY OF DALLAS }

Before me _____ (insert the name of the officer) on this day _____ personally appeared _____ known to me (or proved to me on the oath of _____) or through _____ (description of identity card or other document) to be the person whose name is subscribed to the forgoing instrument and acknowledged to me that he/she executed the same for the purpose and consideration therein expressed.

Given under my hand and seal of office this _____ day of _____, 2_____.

Notary Public in and for the State of Texas _____ Typed or Printed Name of Notary
My Commission Expires: _____

[Surety]

STATE OF TEXAS }
COUNTY OF DALLAS }

This instrument was acknowledged before me on the _____ day of _____, 2_____ by _____ who is the _____ of the Surety, on behalf of Surety.

GIVEN UNDER MY HAND AND SEAL OF OFFICE this the _____ day of _____, 2_____.

Notary Public in and for the State of Texas _____ Typed or Printed Name of Notary
My Commission Expires: _____

1 Please see attached contact sheet for Surety and the Texas Department of Insurance

Payment and Performance Bond Contact Sheet

(1) Claims:

All notices of claims shall be sent to the surety at the following address:

(Name of surety)

(Mailing address)

(Physical address)

(Phone number)

(2) Texas Department of Insurance Contact Number:

The address and contact information of the surety may otherwise be obtained by contacting the Texas Department of Insurance at the following toll free telephone number:

1-800-252-3439.

SECTION MB
MAINTENANCE BOND

MB 1

MAINTENANCE BOND – TWO YEAR

STATE OF TEXAS

COUNTY OF DALLAS

WHEREAS, _____ as principal ("Contractor") and _____ a corporation organized under the laws of _____ and being duly authorized to do business in the State of Texas, as surety ("Surety")(whether one or more), do hereby expressly acknowledge themselves to be held and bound to pay to the Town of Addison, Texas, a home-rule municipality organized and operating under the Constitution and laws of the State of Texas (the "Town"), its successors and assigns the sum of _____ Dollars in the lawful currency of the United States of America (\$)) for the payment of which Contractor and Surety are liable to the Town, jointly and severally; and

WHEREAS, Contractor has this day entered into a written contract with the Town to build and construct which contract and the plans and specifications therein mentioned (collectively referred to hereinafter as the "Contract") are hereby expressly incorporated into and made a part hereof as though set forth at length; and

WHEREAS, under the Contract it is provided that the Contractor will maintain and keep in good repair all work to be performed and done under the Contract for a period of two (2) year from the date of acceptance of the completed work by the Town, and to do and perform all necessary work and repair any defective condition, it being understood that the purpose of this maintenance bond is to insure all warranties, express or implied, made or given by the Contractor to the Town and to cover all defective, inadequate or non-conforming conditions arising by reason of any materials or labor installed, provided, constructed or performed by the Contractor and in case the Contractor shall fail to correct any such conditions it is agreed that the Town may make such corrections and charge the cost of making those corrections against the Contractor and the Surety on this obligation, and the Contractor and Surety shall be subject to the liquidated damages provided in the contract, the plans and the specifications for each day's failure on its part to comply with the terms and provisions of the Contract;

NOW, THEREFORE, if the Contractor shall keep and perform its obligation to maintain the work and keep the work in repair for the full maintenance period of two (2) year as herein provided, then these presents shall be null and void and have no further effect, but if default shall be made by Contractor in the performance of its obligations, then these presents shall have full force and effect, and the Town shall have and recover from the Contractor and its Surety damages in the premises as provided and it is further understood and agreed that this obligation shall be a continuing one against the Contractor and the Surety and that successive recoveries may be had hereon for successive breaches until the full amount of this bond shall have been exhausted; and it is further understood that the obligation under this bond to maintain the work shall continue throughout the maintenance period and shall not be changed, diminished, or in any other manner affected during the term of this bond. The obligations of Contractor and Surety under this bond apply both to the original Contract and to any extension or modification of the Contract and Surety agrees that no change, extension of time, addition, expansion or other modification of the Contract, the work to be done under the Contract, or the plans and specifications which are a part of the Contract shall in any manner affect the obligations of Surety under this bond, and Surety waives notice of any such change, extension of time, addition, expansion or other modification. The obligations of Contractor and Surety under this bond are performable and payable in Dallas County, Texas such that exclusive venue for any legal action pertaining to this bond shall lie in Dallas County, Texas. By their signatures below, the persons signing this bond warrant and represent that they are, respectively, duly authorized to sign on behalf of Contractor and Surety.

EXECUTED this the _____ day of _____, 2_____.
CONTRACTOR: _____ SURETY: _____

By: _____ By: _____
Printed Name: _____ Printed Name: _____
Title: _____ Title: _____

Address of Principal: _____ Address of Surety: _____

ACKNOWLEDGMENTS
[Contractor]

STATE OF TEXAS
COUNTY OF DALLAS

Before me _____ (insert the name of the officer) on this day _____ personally appeared _____ known to me (or proved to me on the oath of _____) or through _____ (description of identity card or other document) to be the person whose name is subscribed to the forgoing instrument and acknowledged to me that he/she executed the same for the purpose and consideration therein expressed.

Given under my hand and seal of office this _____ day of _____, 2_____.

Notary Public in and for the State of Texas _____ Typed or Printed Name of Notary
My Commission Expires: _____

[Surety]

STATE OF TEXAS
COUNTY OF DALLAS

This instrument was acknowledged before me on the ___ day of _____, 2____ by _____ who is the _____ of the Surety, on behalf of Surety.

GIVEN UNDER MY HAND AND SEAL OF OFFICE this the _____ day of _____, 2_____.

Notary Public in and for the State of Texas _____ Typed or Printed Name of Notary

SECTION BP

CONTRACTOR'S AFFIDAVIT OF BILLS PAID

CONTRACTOR'S AFFIDAVIT OF BILLS PAID

STATE OF TEXAS

COUNTY OF DALLAS

Personally, before me the undersigned authority, on this day appeared _____ who, being
duly sworn, on oath, says that he is a legal representative of _____
(full name of Contractor as in contract)

and that the contract for the construction of the project, designated as

BELT LINE ROAD UNDERGROUND ELECTRICAL – PHASE 1

**INFRASTRUCTURE OPERATIONS & SERVICES
BID NUMBER 14-10**

has been satisfactorily completed and that all bills for materials, apparatus, fixtures, machinery and labor used
in connection with the construction of this project have, to the best of my knowledge and belief, been fully
paid.

Signature

Title

Sworn to and subscribed before me this _____ day of _____, 201_.

Notary Public in and for

County, Texas

Instructions:

If the contractor is an individual, he shall sign the affidavit. If the contractor is a partnership, any partner may sign the affidavit. If the contractor is a corporation, a person authorized by the by-laws or by the Board of Directors shall sign the affidavit. If the Contractor is a joint-venture of individuals, any of the individuals may sign the affidavit. If the Contractor is a joint-venture of partnerships, or of individuals and partnerships, the affidavit may be signed by the individual or any partner of any partnership. If the contractor is a joint-venture in which a corporation is a party, separate affidavits must be executed in the name of the joint-venture: one by each corporation and one by each individual or partnership. Signatures for corporations should be by a duly authorized officer. If signature is by another, a showing of authority to sign must accompany the affidavit.

SECTION GP

GENERAL PROVISIONS

GENERAL PROVISIONS

The General Provisions of the Contract shall be as stated in the *Standard Specifications for Public Works Construction – North Central Texas, 4th Edition (2004)*, under Division 100, "General Provisions," Items 101.1 through 109.6 inclusive, as amended or supplemented and except as modified by the Special Provisions or Instructions to Bidders.

SECTION SP

SPECIAL PROVISIONS

Belt Line Road Underground Electrical Phase I – Marsh Lane to Midway Road

SPECIAL PROVISIONS
TABLE OF CONTENTS

<u>Section</u>	<u>Title</u>	<u>Page</u>
1.	<u>SCOPE OF WORK</u>	6
2.	<u>GENERAL</u>	6
3.	<u>EXAMINATION OF SITE</u>	6
4.	<u>SPECIFICATIONS</u>	6
5.	<u>SUBSURFACE INVESTIGATION</u>	7
6.	<u>HISTORICAL, SCIENTIFIC AND ARCHAEOLOGICAL DISCOVERIES</u>	7
7.	<u>ENVIRONMENTAL REQUIREMENTS</u>	8
8.	<u>COMPLIANCE WITH LAWS</u>	10
9.	<u>PERMITS, LICENSES. AND REGULATIONS</u>	10
10.	<u>RIGHTS-OF-WAY AND EASEMENTS</u>	10
11.	<u>RESTRICTED WORK HOURS</u>	11
12.	<u>COMPLIANCE WITH IMMIGRATION LAWS</u>	11
13.	<u>NON-DISCRIMINATION POLICY</u>	11
14.	<u>ANTITRUST LAWS</u>	11
15.	<u>ABANDONMENT</u>	12
16.	<u>DISCREPANCIES</u>	12
17.	<u>PREPARATION OF STORM WATER POLLUTION PREVENTION PLAN</u>	12
18.	<u>ADDENDA</u>	13
19.	<u>PAY ITEMS</u>	13
20.	<u>INCREASE OR DECREASE IN QUANTITIES</u>	13
21.	<u>SUBSIDIARY WORK</u>	13
22.	<u>QUALIFICATION OF BIDS</u>	14
23.	<u>AWARD AND EXECUTION OF CONTRACT</u>	14
24.	<u>EXPLANATION OF CONTRACT TIME</u>	15
25.	<u>COPIES OF PLANS FURNISHED</u>	15
26.	<u>PRE-CONSTRUCTION CONFERENCE</u>	15
27.	<u>MOBILIZATION</u>	15
28.	<u>GENERAL SEQUENCE OF CONSTRUCTION</u>	16
29.	<u>PROJECT REPRESENTATIVE</u>	16

Belt Line Road Underground Electrical Phase I – Marsh Lane to Midway Road

30. COORDINATION WITH OTHERS.....16

31. INSURANCE/ WORKERS COMPENSATION INSURANCE COVERAGE....16

32. RESOLUTION OF DISPUTES.....21

33. SHOP DRAWINGS.....21

34. PROJECT VIDEO22

35. SAMPLES AND TESTS OF MATERIALS22

36. INSPECTION22

37. ACCESS ROUTES, STAGING AREAS AND STORAGE AREAS.....23

38. PROPERTY ACCESS.....23

39. PLANT, PROCEDURES, METHODS AND EQUIPMENT.....23

40. PARKING OF CONSTRUCTION EQUIPMENT.....23

41. ZONING REQUIREMENTS24

42. IN PUBLIC ROADS AND PRIVATE DRIVES24

43. HAULING ON TOWN OF ADDISON STREETS24

44. EXISTING POWER POLES & GUY WIRES.....24

45. SAFETY RESTRICTIONS - WORK NEAR HIGH VOLTAGE LINES25

46. PROTECTION OF EXISTING UTILITIES AND STRUCTURES.....25

47. PUBLIC UTILITIES AND OTHER PROPERTY TO BE CHANGED.....26

48. MAINTENANCE AND REPAIRS26

49. PROTECTION OF WORK.....27

50. PUBLIC CONVENIENCE AND SAFETY27

51. PROTECTION OF PERSONS AND PROPERTY.....28

52. TRAFFIC CONTROL.....29

53. BARRICADES, WARNING SIGNS, DETOURS AND SEQUENCE OF CONSTRUCTION.....29

54. EXCAVATION SAFETY SYSTEMS30

55. TRENCH EXCAVATION, BACKFILL AND COMPACTION.....31

56. TRENCH WALLS.....31

57. SUSPENSION OF WORK RELATED TO DANGER.....31

58. PROPERTY LINES AND MONUMENTS32

59. CONSTRUCTION STAKING32

60. VENDOR’S CERTIFICATION33

61. WATER PIPE33

62. WASTEWATER PIPE33

63. STORM DRAINAGE PIPE.....33

Belt Line Road Underground Electrical Phase I – Marsh Lane to Midway Road

64.	<u>POLYETHYLENE WRAPPING</u>	33
65.	<u>PIPE CLEANING</u>	33
66.	<u>PLUGS</u>	33
67.	<u>CEMENT STABILIZED BACKFILL</u>	33
68.	<u>NON-METALLIC WATER PIPE DETECTION</u>	34
69.	<u>PIPE EMBEDMENT</u>	34
70.	<u>REMOVALS, ADJUSTMENTS AND REPLACEMENTS</u>	34
71.	<u>PAVEMENT REPAIR</u>	35
72.	<u>PAVEMENT REMOVAL AND REPLACEMENT</u>	35
73.	<u>WATER FOR CONSTRUCTION</u>	35
74.	<u>EXISTING STOCKPILES OF MATERIAL ON SITE</u>	35
75.	<u>BORROW SOURCE</u>	35
76.	<u>EXCESS MATERIAL</u>	35
77.	<u>DURING CONSTRUCTION</u>	36
78.	<u>CONSTRUCTION TRAFFIC OVER PIPE LINES</u>	36
79.	<u>CONTRACTOR’S CONTINUING OBLIGATION</u>	36
80.	<u>TOP SOILING, SEEDING AND FERTILIZING</u>	37
81.	<u>IRRIGATION AND SPRINKLER REPAIR</u>	37
82.	<u>REMOVAL OF DEFECTIVE AND UNAUTHORIZED WORK</u>	37
83.	<u>DISPOSITION AND DISPOSAL OF MATERIALS</u>	37
84.	<u>CLEAN-UP FOR FINAL ACCEPTANCE</u>	38
85.	<u>TV INSPECTION OF SANITARY SEWER AND STORM DRAIN SYSTEMS</u>	38
86.	<u>MATERIALS TO BE FURNISHED BY AT&T, TWC AND FIBERLIGHT</u>	38
87.	<u>TESTING REQUIREMENTS</u>	38
88.	<u>SILICONE JOINT SEALANT</u>	38
89.	<u>CLAIMS FOR DAMAGES OR INJURY</u>	39
90.	<u>WAIVER OF CLAIMS</u>	39
91.	<u>MECHANICS AND MATERIALMEN’S LIEN</u>	40
92.	<u>CONTRACTOR’S AFFIDAVIT OF BILLS PAID</u>	40
93.	<u>PRODUCT RECORD DOCUMENTS</u>	40
94.	<u>OWNERSHIP OF WORK AND MATERIALS</u>	41
95.	<u>DRAWINGS AND OTHER DATA</u>	41
96.	<u>TOWN OF ADDISON APPROVAL</u>	42
97.	<u>USE OF EXPLOSIVES</u>	42

Belt Line Road Underground Electrical Phase I – Marsh Lane to Midway Road

98. POWER FOR CONSTRUCTION.....42

99. LIQUIDATED DAMAGES42

100. CONTRACT DELAY42

101. SUBCONTRACTORS42

102. PAYMENTS TO SUBCONTRACTORS43

103. USE OF COMPLETED PORTIONS OF THE WORK43

104. COMPLETE AGREEMENT.....44

105. WAIVER.....44

106. EXECUTION OF THE CONTRACT44

107. DEFINITIONS.....44

108. MODIFICATIONS TO THE LANGUAGE OF THE
GENERAL PROVISIONS45

109. CONTRACTOR REPRESENTATIONS54

110. PREVAILING WAGE RATES.....55

111. BID ITEMS / REFERENCE SPECIFICATIONS.....58-107

SPECIAL PROVISIONS

1. **SCOPE OF WORK:** The Work to be performed under the provisions of these Contract Documents shall consist of furnishing all materials, labor, equipment, supplies and appurtenances; providing all construction, plant, equipment and tools; performing all necessary labor and supervision; and the construction complete, including all Work appurtenant thereto, the proposed improvements for: *Belt Line Road Underground Electrical Phase I* (“Project”).
2. **GENERAL:** This Work shall conform to the requirements of the Specifications and the details as shown on the Plans. These Contract Documents are intended to be complementary. The Contractor shall do all work as provided in the plans, specifications, special provisions, bid and contract, and shall do such additional Extra work as may be considered necessary to complete the work in a satisfactory and acceptable manner. The Contractor shall furnish all labor, tools, materials, machinery, equipment, and incidentals necessary to the satisfactory prosecution and completion of the Work. Requirements of any of the Contract Documents are as binding as if called for by all. In the event of conflict between the Plans and the Specifications, the Contractor will be deemed to have assumed the more expensive way of doing the Work unless, before submitting a bid, the Contractor shall have asked for and obtained (by addendum) a written decision as to which method or material is intended.

In cases of discrepancies, calculated dimensions shall govern over scaled dimensions; Special Provisions and special Specifications shall govern over both General Provisions and standard Specifications; and quantities shown on the Plans shall govern over those shown in the proposal.

3. **EXAMINATION OF SITE:** The Contractor acknowledges that he has investigated and satisfied himself as to the conditions affecting the Work, including but not restricted to those bearing upon transportation, disposal, handling and storage of materials, availability of labor, water, electric power, roads and uncertainties of weather, or similar physical conditions at the site, conditions of the ground, the character of equipment and facilities needed preliminary to and during prosecution of the Work. The Contractor acknowledges that he has inspected the site of the Work and is familiar with the soil conditions to be encountered. Any failure by the Contractor to acquaint himself with the available information will not relieve him from responsibility for estimating properly the difficulty or cost of successfully performing the Work. The Town of Addison assumes no responsibility for any conclusions or interpretations made by the Contractor on the basis of the information made available by the Town and the Engineer.
4. **SPECIFICATIONS:** Construction improvements shall be governed by the following published specifications and details (except as modified by these Special Provisions):

Standard Specifications for Public Works Construction, North Central Texas - North Central Texas Council of Governments (latest edition);

Belt Line Road Underground Electrical Phase I – Marsh Lane to Midway Road

Standard Specifications for Construction and Maintenance of Highways, Streets, and Bridges – Texas Department of Transportation, 2004;

Town of Addison Standard Construction Details;

The Contractor shall keep copies of applicable Specifications on the Project site at all times.

Where reference is made to specifications compiled by other agencies, organizations or departments, such referenced specifications are hereby made a part of the Project Specifications.

5. **SUBSURFACE INVESTIGATION:** Subsurface exploration to ascertain the nature of soils, including the amount of rock, if any, is the responsibility of any and all prospective Bidders. It shall be the responsibility of the Bidders to make such subsurface investigations as he deems necessary to determine the nature of the material to be encountered. Some preliminary subsurface exploration has been performed by the Town of Addison and the Engineer, and is provided to the Contractor in the Contract Documents. This information is provided only as preliminary and all bids shall be based on information obtained by the Contractor. The Town of Addison and the Engineer disclaim any responsibility for the accuracy, true location and extent of the soils information that has been prepared by others. They further disclaim responsibility for interpretation of that data by Bidders, as in projecting soil bearing values, rock profiles, soils stability and the presence, level and extent of underground water.

6. **HISTORICAL, SCIENTIFIC AND ARCHAEOLOGICAL DISCOVERIES:** Contractor shall immediately give an oral and written report to the Town of Addison of the discovery of any articles of historical, scientific, or archaeological significance. Contractor shall take all necessary steps to preserve the article and shall cease operations, which would affect the find until otherwise directed by the Town of Addison but continue with all other unaffected operations. The future operations of Contractor with respect to the discovery, including disposition of the articles, shall be decided by the Town of Addison. The Town of Addison shall have sole and exclusive title to any discovered articles.

The Town of Addison shall investigate the site conditions promptly after receiving the notice. If the conditions do materially so differ and cause an increase or decrease in Contractor's cost of, or the time required for performing any part of the work under the Contract, whether or not changed as a result of conditions, an equitable adjustment will be made and the Contract modified in writing accordingly.

No request by Contractor for an equitable adjustment to the Contract under this Section shall be allowed unless Contractor has given the written notice required. No request by Contractor for an equitable adjustment of the Contract for differing site conditions will be allowed or shall be made after final payment under the Contract.

Belt Line Road Underground Electrical Phase I – Marsh Lane to Midway Road

7. **ENVIRONMENTAL REQUIREMENTS:** In addition to requirements set forth in other sections of the Contract, including the Plans and Specifications, Contractor shall ensure that the requirements of this Section are fulfilled and incorporated into its procedures and processes as well as those of any Subcontractors. All materials utilized by Contractor on the Project shall comply with all applicable local, state and federal laws and regulations.
- A. Contractor is responsible for compliance with any requirements included in the Contract Documents regarding Hazardous Materials. If Contractor encounters a hazardous material or substance not addressed in the Contract Documents and if reasonable precautions will be inadequate to prevent foreseeable bodily injury or death to persons resulting from a material or substance, including but not limited to asbestos or polychlorinated biphenyl (PCB), encountered on the site by Contractor, Contractor shall, upon recognizing the condition, immediately stop Work in the affected area and report the condition to the Town of Addison in writing.
1. The term “Hazardous Materials” means any substance or compound, whether solid, liquid or gaseous: (i) which is listed, defined or regulated as a “hazardous substance”, “hazardous waste”, “extremely hazardous waste”, “solid waste”, “toxic substance”, “hazardous substance”, “hazardous material” or “regulated substance” or otherwise classified as hazardous or toxic, in or pursuant to any Environmental Law; or (ii) which is or contains asbestos, radon, any polychlorinated biphenyl, urea formaldehyde foam insulation, explosive or radioactive material, lead, or motor fuel or other volatile organic compounds; or (iii) which causes or poses a threat to cause a contamination or nuisance on the Project Site or any adjacent property, or (iv) which causes or poses a threat to cause a hazard to the environment or to the health, safety or welfare of persons on or about the Project Site.
 2. The term “Environmental Law” means any federal, state or local law, statute, guidance or policy statement, ordinance, code, rule, regulation, license, authorization, decision, order, injunction or decree, which pertains to health, safety or the environment (including, but not limited to, ground, air, water or noise pollution or contamination, and underground or aboveground tanks) and shall include without limitation, the Comprehensive Environmental Response, Compensation and Liability Act of 1980, as amended, the Resource Conservation and Recovery Act of 1976, as amended, the Occupational Health and Safety Act, the Toxic Substances Control Act, the Texas Water Code and the Texas Solid Waste Disposal Act and any other state or federal environmental statutes.
- B. If the material or substance was on the site prior to the issuance of the Notice to Proceed, the Town of Addison shall obtain the services of a licensed laboratory to verify the presence or absence of the material or substance reported by Contractor and, in the event such material or substance is found to be present, to verify that it

Belt Line Road Underground Electrical Phase I – Marsh Lane to Midway Road

has been remediated to levels required by the Texas Commission on Environmental Quality. When the material or substance has been remediated, Work in the affected area shall resume upon written direction of the Town of Addison.

- C. Except as provided in Subparagraph B., Contractor (with the Town of Addison's prior written approval of the laboratory) shall obtain the services of a licensed laboratory to verify the presence or absence of the material or substance reported by Contractor and, in the event such material or substance is found to be present, the Town of Addison shall determine whether Contractor or the Town of Addison shall have the substance remediated to levels required by the Texas Commission on Environmental Quality. When the material or substance has been remediated, Work in the affected area shall resume upon written direction of the Town of Addison. The Contract time shall not be extended and the Contract Price shall not be increased, unless the material or substance to be remediated were not introduced to the Work Site by Contractor, and Contractor shall then pay for (or reimburse the Town of Addison for) the testing and remediation.
- D. The Town of Addison shall not be responsible under this Section for materials or substances Contractor brings or introduces to the Project Site. Contractor shall be responsible for the fault or negligence in the use and handling of materials or substances of Contractor, Subcontractor, Sub-subcontractor, or anyone directly or indirectly employed by any of them.
- E. Contractor shall indemnify the Town of Addison and its affiliates for any and all damages incurred by the Town of Addison as a result of Contractor's actions with respect to all applicable state and federal environmental laws related to materials or substances Contractor brings to the Project Site, including but not limited to fines, penalties, costs of remediation and reasonable attorney's fees. No time extension shall be granted for breach of this provision.
- F. Contractor agrees that it shall not transport to, use, generate, dispose of, or install at the Project Site any Hazardous Materials, except in accordance with applicable environmental laws. Further, in performing the Work, Contractor shall not cause any release of Hazardous Materials into, or contamination of, the environment, including the soil, the atmosphere, any water course or ground water unless required by the Contract Documents. In the event Contractor engages in any of the activities prohibited in this Section or fails to stop Work as provided in this Section, to the fullest extent permitted by law, Contractor hereby indemnifies and holds the Town of Addison, its affiliates and their respective officers, agents, employees and tenants harmless from and against any and all claims, damages, losses, causes of action, suits and liabilities of every kind, including but not limited to, expenses of litigation, court costs, punitive damages and attorneys' fees, arising out of, incidental to or resulting from the activities prohibited in this Section or Contractor's failure to stop Work as required. Contractor shall obtain from manufacturers and furnish to the Town of Addison Materials Safety Data Sheets (OSHA Form 20) for all materials incorporated into the Project by

Belt Line Road Underground Electrical Phase I – Marsh Lane to Midway Road

Contractor. The Town of Addison hereby agrees that, as between the Town of Addison and Contractor, the Town of Addison will be responsible for Hazardous Materials on site which existed prior to Contractor performing Work on the Project Site or which are introduced to the Project Site by the Town of Addison, except as provided in this Section. Contractor will not be considered the generator of Hazardous Materials on site which existed prior to Contractor performing Work on the Work Site or which are introduced to the Project Site by the Town of Addison. If the Hazardous Materials were on the Project Site prior to Contractor's presence on the Project Site or were introduced to the Project Site by the Town of Addison, then, if appropriate, the Town of Addison will make an equitable adjustment to the Contract.

- G. Include in all construction subcontracts exceeding \$100,000, the following requirement: "Contractor is responsible for compliance with all applicable standards, orders, or requirements issued under Section 306 of the Clean Air Act, Section 505 of the Clean Water Act, Executive Order 11738, and Environmental Protection Agency regulations."
 - H. No request by Contractor for an equitable adjustment to the Contract under this Section shall be allowed unless Contractor has given the written notice required.
 - I. No request by Contractor for an equitable adjustment of the Contract for Hazardous Materials will be allowed or shall be made after final payment under the Contract.
8. **COMPLIANCE WITH LAWS:** The Contractor shall familiarize himself with the nature and extent of the Specifications, Plans, Project Site conditions, traffic and safety requirements, and shall fully comply with all local, state and federal laws, including all codes, ordinances, rules and regulations applicable to this Contract and the Work to be done hereunder, which exist or which may be enacted later by governmental bodies having jurisdiction or authority for such enactment. The Contractor shall comply with all federal, state and local laws, rules and regulations of every kind and nature applicable to the performance of its Work hereunder, and shall hold the Town of Addison and the Engineer harmless therefrom. No plea of ignorance or misunderstanding thereof will be considered.
9. **PERMITS, LICENSES. AND REGULATIONS:** Permits and licenses for the prosecution of the Work shall be secured and paid for by the Contractor. Any required permit fees will still be paid by the Contractor. Wherever the Work under this contract requires the obtaining of permits from the Town of Addison or other public authorities, duplicate copies of such permits shall be furnished to the Engineer by the Contractor hereunder before the Work covered thereby is started. **NO WORK WILL BE ALLOWED TO PROCEED BEFORE SUCH PERMITS ARE OBTAINED.**
10. **RIGHTS-OF-WAY AND EASEMENTS:** Rights-of-way and permanent easements, dedicated to the Town of Addison, will be secured for this Project and made a part of thereto. The Contractor shall obtain a right-of-way permit from the Town of Addison

Belt Line Road Underground Electrical Phase I – Marsh Lane to Midway Road

prior to beginning Work. When working within the public rights-of-way and easements, the Contractor shall at all times observe and comply with all Federal and State Laws, and Town of Addison ordinances and regulations which in any way affect the conduct of the Work or its operations, and shall observe and comply with all orders, laws, ordinances and regulations which exist or which may be enacted later by bodies having jurisdiction or authority for such enactment. No plea of misunderstanding or ignorance thereof will be considered. The Contractor and his Sureties shall indemnify and save harmless the Town of Addison, the Engineer and all of their officers, agents, and employees against any and all claims or liability arising from or based on the violation of any such law, ordinance, regulation, or order, whether it be by itself or its employees.

It shall be the responsibility of the Contractor, prior to the initiation of construction on easements through private property, to inform the property owner of its intent to begin construction. Before beginning construction in areas of public dedication, the Contractor shall inform the agency having jurisdiction in the area forty-eight (48) hours prior to initiation of the Work. All easements shall be cleaned up after use and restored to their original conditions or better.

11. **RESTRICTED WORK HOURS:** Per the Town of Addison Building Regulations, “It shall be unlawful for a person, firm or corporation to excavate, erect, build, construct, alter, repair or demolish any building or structure which has been issued or which is required to be issued a building permit by the Town of Addison between the hours of 7:00 p.m. and 7:00 a.m. Monday through Friday, and between the hours of 7:00 p.m. and 8:00 a.m. on Saturday and Sunday, if such activity is performed within a residential, apartment, or townhouse zoned area, or within three hundred (300) feet of an occupied residence, except in cases of urgent necessity or in the interest of public safety and convenience, and then only by permit of the City Manager.”

It is in the interest of the public safety and convenience for the Work under this Project to occur outside the standard Work hours. However, the contractor will must present a detailed Work schedule and obtain written approval from the Town.

12. **COMPLIANCE WITH IMMIGRATION LAWS:** Contractor shall take all steps necessary to ensure that all of the Contractor’s employees are authorized to work in the United States as required by the Immigration Reform and Control Act of 1986.
13. **NON-DISCRIMINATION POLICY:** It is the policy of the Town of Addison to afford all people an equal opportunity to bid on any contract being let by the Town. The Town of Addison has a policy that prohibits discrimination against any person because of race, color, sex, or national origin, in the award or performance of any contract. The Town of Addison will require its employees, agents, and Contractors to adhere to this policy.
14. **ANTITRUST LAWS:** The Contractor hereby assigns to the Town of Addison any and all claims for overcharges associated with this contract which arise under the antitrust laws of the United States 15 U.S.C.A. Sec. 1, et seq. (1973).

Belt Line Road Underground Electrical Phase I – Marsh Lane to Midway Road

15. **ABANDONMENT:** The Town of Addison reserves the right to abandon, without obligation to the Contractor, any part of the Project, or the entire Project, at any time before the Contractor begins any construction Work authorized by the Town of Addison. In case of total abandonment of the Project, the Contract becomes void. The Town of Addison may abandon portions of the Project at any time during the Project duration. In case of such partial abandonment, the Contractor shall not be due any payment for lost or unrealized profits on the abandoned portions of the Project.

16. **DISCREPANCIES:** If the Contractor, in the course of the Work, finds any discrepancy between the Contract Documents and the physical conditions of the Project, or any errors or omissions in Plans or in the layout as given by survey points and instructions, or if it appears that any Plan, Specification or other Contract Document is or may not be in compliance with any building code or other requirement of any governmental body, he shall immediately inform the Town of Addison and the Engineer in writing, and the Town of Addison and the Engineer shall promptly verify the same. Any Work done after such discovery, until authorized, will be done at the Contractor's risk.

17. **PREPARATION OF STORM WATER POLLUTION PREVENTION PLAN:** A Storm Water Pollution Prevention Plan (SW3P) will be prepared by the Contractor in accordance with the Texas Pollution Discharge Elimination System, General Permit Number TXR150000 relating to Discharges from Construction Activities issued by the Texas Commission on Environmental Quality (TCEQ). The SW3P will include the following information as required by the TCEQ Permit: Project description that includes: description of the construction activities, intended schedule or sequence of major soil disturbing activities, number of total acres of the Project area and number of acres where soil will be disturbed, estimate of the runoff coefficient of the site for pre-construction and post-construction conditions, data describing the soil, a general location map, the name of receiving waters at or near the site, and a copy of the TPDES General Permit.

A Best Management Plan is provided in the Plans with minimum elements for perspective Bidders. The contractor is required to prepare a detailed site map will be prepared showing drainage patterns and approximate slopes after grading, areas where soil disturbance will occur, locations of major structural controls, locations where stabilization practices are expected to be used, surface waters, and locations where storm water discharges from the site directly to a surface water.

The Contractor shall prepare a SW3P and submit a Notice of Intent (NOI) as required by the TPDES Permit if the total disturbed area is 5 acres or more.

A three-ring SW3P binder will be prepared containing all information and reports that are required as part of the SW3P. The Contractor will be required to prepare and utilize the SW3P as listed above, and maintain all records on-site during the Project including performing inspections and maintaining all required documentation required by the TPDES General Permit.

Belt Line Road Underground Electrical Phase I – Marsh Lane to Midway Road

This specification is not all inclusive of the requirements for an SW3P. The Contractor shall comply with all requirements of the TCEQ TPDES permit and the local authorities' storm water ordinance and/or regulations.

The SW3P plan provided by the Contractor shall be designed, signed, and sealed by a professional engineer registered in Texas.

18. **ADDENDA:** Bidders desiring further information, or interpretation of the Plans and Specifications, must make written request for such information to the Engineer (not later than three (3) working days prior to the date set for the Bid opening. The ability to ask questions will close at 2:00 PM, Monday April 14, 2014. Answers to all such requests will be issued in the form of Addenda and a copy of such Addenda will be released through *www.bidsync.com*. It will be the responsibility of each person who has been issued as set of Bidding Documents to secure all Addenda from *www.bidsync.com*. Addenda will be bound with and made a part of the Contract Documents. No other explanation or interpretation will be considered official or binding. Should a Bidder find discrepancies in, or omissions from, the Plans, Specifications or Contract Documents, or should it be in doubt as to their meaning, it shall at once notify the Engineer in writing in order that a written addendum may be sent to all Bidders.
19. **PAY ITEMS:** Pay items provided are intended to be all-inclusive of the Work required on this Project. Work required by the Plans or Specifications but not provided with a specific pay item shall be considered incidental to other items of Work. Final payment to the construction Contractor shall not be made until all Work has been finally completed and verified in accordance with the construction contract, Plans and Specifications and have been finally accepted by the Town of Addison.

See bid item descriptions/reference specifications for details.

20. **INCREASE OR DECREASE IN QUANTITIES:** The quantities shown in the proposal are approximate. Final payment will be based on quantities determined by measurement methods described for each Work item.

When the quantity of Work to be done or materials to be furnished under any major pay item or contract is more than 125% of the quantity stated in the contract, whether stated by Town of Addison or by Contractor, then either party to the contract, upon demand, shall be entitled to negotiate for revised consideration on the portion of Work above 125% of the quantity stated in the contract.

When the quantity of the Work to be done or materials to be furnished under any major pay item of the contract is less than 75% of the quantity stated in the contract, whether stated by Town of Addison or by Contractor, then either party to the contract, upon demand, shall be entitled to negotiate for revised consideration on the portion of Work below 75% of the quantity stated in the contract. This paragraph shall not apply in the event Town of Addison deletes a pay item in its entirety from this contract.

21. **SUBSIDIARY WORK:** Any and all Work specifically governed by documentary requirements for the Project, such as conditions imposed by the Plans or these Special

Belt Line Road Underground Electrical Phase I – Marsh Lane to Midway Road

Provisions, in which no specific item for bid has been provided for in the Proposal, shall be considered as a subsidiary item of Work, the cost of which shall be included in the various bid items in the Proposal. Costs of permits, inspection fees, traffic control, construction staking, surface restoration and cleanup are general items of Work which fall in the category of subsidiary Work. Any repairs or replacement of items damaged during demolition or as a result of new construction will be considered subsidiary. Limits of all Work requiring repair will be determined by the Town of Addison staff or the inspector. Extreme care should be taken during all demolition and construction operations.

22. **QUALIFICATION OF BIDS:** The Town of Addison reserves the right to reject any and all Bids, to waive any and all informalities not involving price, time or changes in the Work, and the right to disregard all nonconforming, non-responsive, unbalanced, or conditional Bids. The Town reserves the right to reject the Bid of any Bidder if the Town believes that it would not be in the best interest of the Project to make an award to that Bidder, whether because the Bid is not responsive or the Bidder is unqualified or of doubtful financial ability or fails to meet any other pertinent standard or criteria established by the Town. Discrepancies in the multiplication of units of Work and unit prices will be resolved in favor of the unit prices. Discrepancies between the indicated sum of any column of figures and the correct sum thereof will be resolved in favor of the correct sum.

To be considered responsive, the apparent three lowest Bidders are required to submit the Statement of Experience per Spec 00 45 16 within 5 days.

The apparent low three Bidders will be notified by the Engineer to request the information.

23. **AWARD AND EXECUTION OF CONTRACT:** For the purpose of award, each bid submitted shall consist of three parts whereby the correct summation of the products of the estimated quantities shown in the proposal, multiplied by their bid unit prices for the following parts:

- Base Bid – Parts 1 thru 10**
- Additive Alternative No. 1 – Part 11**

The method of Award will be as shown below:

**Award = Total Base Bid or
Total Base Bid + Additive Alternative No. 1**

The Town reserves the right to accept whichever bid is determined to be in the best interest of the public and to reject all bids.

All payments will be based on actual quantities and bid unit prices.

Belt Line Road Underground Electrical Phase I – Marsh Lane to Midway Road

24. **EXPLANATION OF CONTRACT TIME:** The term “Contract Time” as used in this Provision will mean the 458 calendar days for completion of the Work of the Contract from the date the Contract was executed. The term “calendar day” as used in this Article will mean every day shown on the calendar. Calendar days will be consecutively counted from commencement of Contract Time regardless of weather, weekends, holidays, suspensions of Contractor’s operations, delays or other events as described herein.

In the event of a catastrophic event (i.e., war, invasion, riot, declared state of emergency, national strike, or other situations as declared by the Town of Addison) directly and substantially affecting the Contractor’s operations on the Contract, the Contractor and the Town shall agree as to the number of calendar days to extend the Contract Time. In the event the Contractor and Town are unable to agree to the number of calendar days to extend the Contract Time, the Town shall unilaterally determine the number of calendar days to extend the Contract Time reasonably necessary and due solely to such catastrophic event and the Contractor shall have no right whatsoever to contest such determination, save and except that the Contractor establishes that the number of calendar days determined by the Town were arbitrary or without any reasonable basis.

Should the Contractor fail to complete the Contract on or before expiration of the Allowable Contract Time, as adjusted in accordance with the provisions above, the Town shall deduct from the moneys due the Contractor the Daily Value as shown in provision 99 for each calendar day completion exceeds the Allowable Contract Time. The term “Allowable Contract Time” as used in this Article shall mean the Original Contract Time plus adjustments pursuant to the statements above. This deduction shall be the disincentive for the Contractor’s failing to timely complete the Contract. **This shall be strictly enforced.**

25. **COPIES OF PLANS FURNISHED:** One (1) copy of 11” x 17” and one (1) electronic copy of the Plans shall be furnished to the successful Contractor, at no charge, for construction purposes. Additional copies may be obtained at cost of \$150.00 per set upon request.
26. **PRE-CONSTRUCTION CONFERENCE:** The successful Contractor, Engineer, and Town of Addison shall meet for a pre-construction conference before any of the Work begins on this Project. At this time, details of sequencing of the Work, contact individuals for each party, testing requirements, submittals, and pay requests will be covered. Prior to the meeting, the Contractor shall prepare schedules showing the sequencing and progress of their Work and its effect on others. A final composite schedule will be prepared during this conference to allow an orderly sequence of Project construction.
27. **MOBILIZATION:** The Work specified in this item consists of the preparatory Work and operations in mobilizing for beginning Work on the Project, including, but not limited to, those operations necessary for the movement of personnel, equipment, supplies and incidentals to the Project site, and for the establishment of temporary offices, utilities, and other facilities, if necessary, for the construction of proposed improvements. The provisions of TxDOT Standard Specification Item (TxDOT Item

Belt Line Road Underground Electrical Phase I – Marsh Lane to Midway Road

500) “Mobilization” shall apply, except the maximum amount allowed will be 5% of the total bid amount.

28. **GENERAL SEQUENCE OF CONSTRUCTION:** Prior to the start of Work, the Contractor shall develop a detailed construction and sequence of construction schedule using the critical path method (CPM) and submit to the Town of Addison for approval. The CPM shall reflect all definable features of Work and activities that shall cause minimum interference with traffic along, across and adjacent to the Project during construction. If the schedule or sequence becomes unworkable or unsatisfactory as Work proceeds, adjustments shall be made. During all phases of construction access to all existing residences and businesses must be maintained at all times unless otherwise authorized in writing by the Town of Addison. Erosion control devices must be properly installed and maintained during all stages of construction.

The Contractor must comply with all lane closure and traffic movement restrictions as indicated in the Plans unless specifically authorized in writing by the Town of Addison.

The general intent is for the contractor to begin at one end and steadily progress limiting the area of construction to minimize disruptions to the traveling public, residences and businesses along the route.

29. **PROJECT REPRESENTATIVE:** The Town of Addison, the Engineer, the Contractor(s), and any applicable public utilities shall designate a single individual within their organization to act as liaison for the Project. This individual shall be aware of the day to day activities on the Project, have authority to make decisions binding on the party, and serve as single point for coordination of activities with the other team members. The Contractor’s representative must be available to meet and discuss construction related issues on site or at the Town’s offices within 20 minutes of a request during working hours and throughout the entire construction period. Upon repeated failure of attendance at requested meetings, Contractor will be required to have a Project representative on-site at all times.
30. **COORDINATION WITH OTHERS:** In the event that other Contractors are doing Work in the same area simultaneously with this Project, the Contractor shall coordinate his proposed construction with that of the other Contractors. The Town of Addison and/or the Engineer shall mediate any disputes, and the Contractors shall comply with their decisions.
31. **INSURANCE:** Each insurance policy that the Contractor must furnish in accordance with these contract documents shall name the Town of Addison and the Engineer as additional insured. Contractor shall include in their bid package, a copy of their certificate of insurance showing compliance to the limits established by the Town of Addison.

1.0 The Contractor shall agree to furnish and maintain continuously during the period of this agreement, any renewals or extension, insurance coverage meeting all of the following requirements:

Belt Line Road Underground Electrical Phase I – Marsh Lane to Midway Road

1.1 Commercial General Liability Insurance at minimum combined single limits of \$1,000,000 per occurrence and \$2,000,000 general aggregate for Bodily Injury and Property Damage, which coverage shall include Products/Completed Operations, and XCU Hazards. Coverage for product/completed operations must be maintained for at least two (2) years after the construction Work has been completed. Coverage must be amended to provide for an each-project aggregate limit of insurance. Contractual Liability must be included.

1.2 Workers Compensation Insurance at statutory limits, including employer's liability coverage at minimum limits of \$1,000,000 each occurrence-each accident, \$1,000,000 by disease-each occurrence and \$1,000,000 by disease aggregate

1.3 Commercial Automobile Liability Insurance at minimum combined single limits of \$1,000,000 per occurrence for bodily injury and property damage, including owned, non-owned, and hired car coverage.

1.4 Umbrella Liability at minimum limits of \$1,000,000 each-occurrence \$4,000,000 aggregate with respect to primary commercial general liability, automobile liability and employer's liability policies.

1.5 Any Subcontractor(s) hired by the Contractor shall maintain insurance coverage equal to that required by the Contractor. It is the responsibility of the Contractor to assure compliance with this provision. The Town accepts no responsibility arising from the conduct, or lack of conduct, of the Subcontractor.

1.6 A comprehensive general liability insurance form may be used in lieu of a commercial general liability form. In this event, coverage must be written on an occurrence basis, at limits of \$1,000,000 each-occurrence, combined single limit and coverage must include a broad form comprehensive general liability endorsement, products/completed operations, XCU hazards and contractual liability.

2.0 With reference to the foregoing insurance requirements, Contractor shall specifically endorse applicable insurance policies as follows:

2.1 The Town shall be named as an additional insured with respect to general liability and automobile liability.

2.2 All liability policies shall contain no cross liability exclusions or insured versus insured restrictions.

2.3 A waiver of subrogation in favor of the Town of Addison shall be contained in the workers compensation and all liability policies.

2.4 All insurance policies shall be endorsed to require the insured to immediately notify the Town of Addison of any material changes in the insurance coverage.

Belt Line Road Underground Electrical Phase I – Marsh Lane to Midway Road

- 2.5 All insurance policies shall be endorsed to the effect that the Town will receive at least thirty (30) days notice prior to cancellation or non-renewal of the insurance.
- 2.6 All certificates shall be mailed to Town of Addison, Purchasing Dept., P.O. Box 9010, Addison, Texas 75001 or emailed to purchasing@addisontx.gov.
- 2.7 All insurance policies, which name the Town as an additional insured, must be endorsed to read as primary coverage regardless of the application of other insurance.
- 2.8 Required limits may be satisfied by any combination of primary and umbrella liability insurances.
- 2.9 Contractor may maintain reasonable and customary deductibles, subject to approval by the Town.
- 3.0 All insurance shall be purchased from an insurance company who meets the following requirements:
- 3.1 Must be issued by a carrier, which is rated “A-” VII or better by A.M. Best’s Key Rating Guide.
- 3.2 Licensed and admitted to do business in the State of Texas and is a subscriber to the Texas Guaranty Fund.
- 4.0 All insurance must be written on forms filed with and approved by the Texas State Board of Insurance. Certificates of insurance shall be prepared and executed by the insurance company or its authorized agent and shall contain provisions representing and warranting the following:
- 4.1 Set forth all endorsements and insurance coverages according to requirements and instruction contained herein.
- 4.2 Shall specifically set forth the notice-of-cancellation or termination provisions to the Town.
- 5.0 Upon request, Contractor shall furnish the Town of Addison with certified copies of all insurance policies.

WORKERS’ COMPENSATION INSURANCE COVERAGE:

A. Definitions.

Certificate of Coverage (“certificate”) - A copy of a certificate of insurance, a certificate of authority to self insure issued by the Texas Workers’ Compensation Commission (the “TWCC”), or a coverage agreement (TWCC-81, TWCC-82, TWCC-83 or TWCC-84), showing statutory workers’ compensation insurance coverage for the person’s or entity’s employees providing services on a Project, for the duration of the Project.

Belt Line Road Underground Electrical Phase I – Marsh Lane to Midway Road

Duration of the Project - includes the time from the beginning of the Work on the Project until the Contractor's/person's Work on the Project has been completed and accepted by the governmental entity.

Persons Providing Services on the Project ("Subcontractor" in Section 406.096 of the Texas Labor Code) - includes all persons or entities performing all or part of the services the Contractor has undertaken to perform on the Project, regardless of whether that person contracted directly with the Contractor and regardless of whether that person has employees. This includes, without limitation, independent Contractors, Subcontractors, leasing companies, motor carriers, Town-operators, employees of any such entity or employees of any entity which furnishes persons to provide services on the Project. "Services" include, without limitation, providing, hauling, or delivering equipment or materials, or providing labor, transportation, or other service related to a Project. "Services" does not include activities unrelated to the Project, such as food/beverage vendors, office supply deliveries, and delivery of portable toilets.

B. The Contractor shall provide coverage, based on property reporting of classification codes and payroll amounts and filing of any coverage agreement, which meets the statutory requirements of Texas Labor Code, 401.011(44) for all employees of the Contractor providing services on the Project, for the duration of the Project.

C. The Contractor must provide a certificate of coverage to the Town of Addison prior to being awarded the contract.

D. If the coverage period shown on the Contractor's current certificate of coverage ends during the duration of the Project, the Contractor must, prior to the end of the coverage period, file a new certificate of coverage with the Town of Addison, showing that the coverage has been extended.

E. The Contractor shall obtain from each person providing services on the Project, and provide to the Town of Addison:

(1) a certificate of coverage, prior to that person beginning Work on the Project, so that the Town of Addison will have on file certificates of coverage showing coverage for all persons providing services on the Project; and,

(2) no later than seven days after receipt by the Contractor, a new certificate of coverage showing extension of coverage, if the coverage period shown on the current certificate of coverage ends during the duration of the Project;

F. The Contractor shall retain all required certificates of coverage on file for the duration of the Project and for one year thereafter.

G. The Contractor shall notify the Town of Addison in writing by certified mail or personal delivery, within 10 days after the Contractor knew or should have known, of any change that materially affects the provision of coverage of any person providing services on the Project.

Belt Line Road Underground Electrical Phase I – Marsh Lane to Midway Road

H. The Contractor shall post on each Project site a notice, in the text, form and manner prescribed by the TWCC, informing all persons providing services on the Project that they are required to be covered, and stating how a person may verify current coverage and report failure to provide coverage.

I. The Contractor shall contractually require each person with whom it contracts to provide Services on a Project to:

(1) provide coverage, based on proper reporting of classification codes and payroll amounts and filing of any coverage agreements, which meets the statutory requirements of Texas Labor Codes 401.011 (44) for all its employees providing services on the Project, for the duration of the Project;

(2) provide to the Contractor, prior to that person beginning Work on the Project, a certificate of coverage showing that coverage is being provided for all employees of the person providing services on the Project, for the duration of the Project;

(3) provide the Contractor, prior to the end of the coverage period, a new certificate of coverage showing extension of coverage, if the coverage period shown on the current certificate of coverage ends during the duration of the Project;

(4) obtain from each person with whom it contracts, and provide to the Contractor;

a. a certificate of coverage, prior to the other person beginning Work on the Project; and,

b. a new certificate of coverage showing extension of the coverage period, prior to the end of the coverage period, if the coverage period shown on the current certificate of coverage ends during the duration of the Project.

(5) retain all required certificates of coverage on file for the duration of the Project and for one year thereafter;

(6) notify the Town of Addison in writing by certified mail or personal delivery, within 10 days after the person knew or should have known, of any change that materially affects the provision of coverage of any person providing services on the Project; and

(7) contractually require each other person with whom it contracts to perform as required by paragraphs (1) - (7) with the certificate of coverage to be provided to the person for whom they are providing services.

J. By signing this contract or providing or causing to be provided a certificate of coverage, the Contractor is representing to the Town of Addison that all employees of the Contractor who will provide services on the Project will be covered by worker's compensation coverage for the duration of the Project, that the coverage will be based on proper reporting of classification codes and payroll amounts, and that all coverage agreements will be filed with the appropriate insurance carrier or, in the case of a self-insured, with the TWCC's Division of Self-Insurance Regulation. Providing false or

Belt Line Road Underground Electrical Phase I – Marsh Lane to Midway Road

misleading information may subject the Contractor to administrative penalties, criminal penalties, civil penalties or other civil actions.

K. The Contractor's failure to comply with any of these provisions is a breach of contract by the Contractor which entitles the Town of Addison to declare the contract void if the Contractor does not remedy the breach within ten days after receipt of notice of breach from the Town.

The following is the form of notice of workers' compensation coverage prescribed by the TWCC. Pursuant to Section 110.110 (d) (7), this notice must be printed with a title in at least 30-point bold type, and text in at least 19-point nominal type, and shall be in both English and Spanish and any other language common to the worker population.

REQUIRED WORKERS' COMPENSATION COVERAGE

"The law requires that each person working on this site or providing services related to this construction Project must be covered by workers' compensation insurance. This includes persons providing, hauling or delivering equipment or materials, or providing labor or transportation or other service related to the Project, regardless of the identity of their employer or status as an employee.

"Call the Texas Workers' Compensation Commission (TWCC) at (512) 440-3789 to receive further information on the legal requirements for coverage, to verify whether your employer has provided the required coverage, or to report an employer's failure to provide coverage."

32. **RESOLUTION OF DISPUTES:** The parties hereby covenant and agree that in the event of any controversy, dispute, or claim, of whatever nature arising out of, in connection with or in relation to the interpretation, performance or breach of this Contract, including but not limited to any claims based on contract, tort or statute, before filing a lawsuit, the parties agree to submit the matter to Alternative Dispute Resolution pursuant to the laws of the State of Texas. The parties shall select a third party arbitrator or mediator from the current list of neutrals on file with the Alternative Dispute Resolution Administrator of the Dallas County District Courts or other mutually agreeable mediator or arbitrator. All forms of Alternative Dispute Resolution may be used except binding arbitration. The proceedings shall be conducted in accordance with the laws of the State of Texas.
33. **SHOP DRAWINGS:** The Contractor shall provide, review, approve and submit all shop drawings, product data and samples required by the Town of Addison, the Engineer and the Contract Documents in accordance with Item 1.28 of the Standard Specifications for Public Works Construction, North Central Texas Council of Governments. The Contractor shall furnish a minimum of four and a maximum of six copies of shop drawings for review by the Engineer, who will review, approve and forward to the Town of Addison for acceptance. Approved submittals will be returned as follows:

Belt Line Road Underground Electrical Phase I – Marsh Lane to Midway Road

Two (2) – Town of Addison

One (1) – Contractor

One (1) – Halff Associates

Maximum size of submittals shall be 11 x 17 inch. No fax copies are acceptable. Shop drawings shall include all items to be installed in the Project, including but not limited to:

- | | | |
|---|---|---|
| <input type="checkbox"/> Paving Mix Designs | <input type="checkbox"/> Traffic Control Plan | <input type="checkbox"/> Water Main Pipe |
| <input type="checkbox"/> Storm Sewer Pipe | <input type="checkbox"/> Sanitary Sewer Pipe/Fittings | <input type="checkbox"/> Valves & Boxes |
| <input type="checkbox"/> Fire Hydrants | <input type="checkbox"/> Manholes & Vaults | <input type="checkbox"/> Backfill Materials |
| <input type="checkbox"/> Conduit | <input type="checkbox"/> Finishes | <input type="checkbox"/> Signal components |

34. **PROJECT VIDEO:** Prior to the start of construction, Contractor shall video the construction area and property adjacent to construction in the presence of the City Inspector. The format shall be DVD. The video shall be narrated. The Contractor shall furnish the Town of Addison a copy of the video in DVD format prior to commencement of Project. This shall be subsidiary to Project.

35. **SAMPLES AND TESTS OF MATERIALS:** The Town of Addison shall designate and pay an independent testing laboratory to furnish testing for this Project. Random testing will be provided by the independent lab as necessary for compliance with the Specifications. The Contractor shall coordinate construction with the testing lab and the Town of Addison, and shall provide assistance to the testing labs by providing excavation, access, trench safety, materials for testing and any other Work required to insure all testing requirements are met. Work performed to accommodate testing will be a subsidiary item and no extra payment will be authorized. All costs for the field quality control testing shall be paid for by the Town of Addison, except for any and all re-testing, which shall be paid by the Contractor and such cost shall be deducted from monthly pay requests. As a guide, the Contractor shall be responsible for providing any test required by the Specifications.

All samples and tests shall be performed in accordance with the Standard Specifications for Public Works Construction, North Central Texas Council of Governments (Latest Edition) as amended or supplemented.

36. **INSPECTION:** The Town of Addison and the Engineer reserve the right to inspect, test, measure or verify the construction Work for this Project as they deem necessary to ascertain that the Work is being accomplished in accordance with the standards and requirements set forth in the Contract Documents. Notwithstanding such reviews, the Contractor will be held responsible for the finished Work and any acceptance of the Work by the Town or governmental agencies will not relieve the Contractor from responsibility for the Work. The Town reserves the right to place full-time construction inspectors at the site of the Work. Costs for inspection services will be paid by the Town of Addison. The Contractor shall provide assistance to the Town of Addison and the Engineer by providing excavation, trench safety, or other Work necessary to facilitate

Belt Line Road Underground Electrical Phase I – Marsh Lane to Midway Road

inspection activities, and shall give sufficient notice well in advance of pending construction activities for scheduling of inspection services.

If the Specifications, the Town's instructions, laws, ordinances, or any public authority require any Work to be specially tested, the Contractor shall give the Town timely notice of its readiness for testing, and if the testing is by an authority other than the Town, of the date fixed for such testing. Tests by the Town shall be made promptly, and where practicable at the source of supply.

37. **ACCESS ROUTES, STAGING AREAS AND STORAGE AREAS:** All haul roads and access routes and the location of job site trailers, staging areas, and storage areas shall be subject to the approval of the Town and the Engineer. The Contractor shall be responsible for maintaining and repairing all roads and other facilities used during construction. Upon completion of the Project all existing roads and other disturbed areas shall be left in a condition equal to that at the time the Contractor commences Work on this Project.
38. **PROPERTY ACCESS:** Access to adjacent properties shall be maintained at all times unless otherwise directed by the Engineer and/or Town of Addison. Contractor shall also maintain sufficient access throughout the Project limits to the existing apartment buildings and businesses during construction operations.
39. **PLANT, PROCEDURES, METHODS AND EQUIPMENT:** The Contractor shall determine the methods to be employed, the procedures to be followed, and equipment to be used on the Work under this contract, subject to the requirements of these Specifications and approval of the Engineer and Town of Addison. Only adequate and safe procedures, methods and equipment shall be used.

The Contractor shall so arrange his Work and provide such plant and equipment as is necessary in order to meet the progress requirements of the approved time schedule and to complete the Work within the period of time as specified in the Contract. Only such materials and equipment as are necessary for the construction of the Work under this contract shall be placed, stored or allowed to occupy any space at the site of the Work.

It is expressly agreed that the acceptance or approval of any order of procedure, methods or equipment submitted or employed by the Contractor shall not in any manner relieve the Contractor of responsibility for the safety, maintenance and repairs of any Work, or for the construction maintenance and safety of the Work hereunder, or from any liability whatsoever on account of any procedure or method employed by the Contractor.

Where the Work under this contract requires permits from the Town of Addison, the State of Texas, or other public authorities, duplicate copies of such permits shall be furnished to the Engineer by the Contractor before the Work covered thereby is started.

NO WORK WILL BE ALLOWED TO PROCEED BEFORE REQUIRED PERMITS ARE OBTAINED AND DISTRIBUTED.

40. **PARKING OF CONSTRUCTION EQUIPMENT:** At night and during all other periods of time when equipment is not being actively used on the construction Work, the

Belt Line Road Underground Electrical Phase I – Marsh Lane to Midway Road

Contractor shall park the equipment at locations which are approved by the Town of Addison. The Contractor shall provide adequate barricades, markers and lights to protect the Town of Addison, the Engineer, the public and other Work. All barricades, lights, and markers must meet the requirements of the Town of Addison, State and Federal regulations.

41. **ZONING REQUIREMENTS:** During the construction of this Project, the Contractor shall comply with the present zoning requirements of the Town of Addison in the use of vacant property for storage purposes.
42. **IN PUBLIC ROADS AND PRIVATE DRIVES:** No public road shall be entirely closed overnight. It shall be the responsibility of the Contractor to build and maintain all weather bypasses and detours, if necessary, and to properly light, barricade and mark all bypasses and detours that might be required on and across the roads involved in the Work included in this Contract. No interference with traffic flow on city streets shall be permitted during the hours of 6:30 a.m. to 9:30 a.m. and 3:30 p.m. to 7:30 p.m., Mondays through Fridays.

The Contractor shall make every effort to complete construction and allow immediate access to adjacent property at driveway entrances located along the roadways. Towns or tenants of improvements where access and/or entrance drives are located shall be notified at least twenty-four (24) hours prior to the time the construction will be started at their driveways or entrances and informed as to the length of time driveways will be closed. Contractor shall at all times maintain at least one point of access into all properties, unless obtaining written permission from property Town to do otherwise with such written permission being provided to the Town's inspector.

The Contractor shall be responsible for all road and entrance reconstruction and repairs and maintenance of same for a period of two years from the date of Town of Addison's acceptance of the Work. In the event the repairs and maintenance are not made immediately to the satisfaction of the Town, and it becomes necessary for the Town to make such repairs, the Contractor shall reimburse the Town for the cost of such repairs.

The Contractor shall, at all times, keep a sufficient width of the roadway clear of dirt and other material to allow the free flow of traffic. The Contractor shall assume any and all responsibility for damage, personal or otherwise, that may be caused by the construction along roads and private drives.

43. **HAULING ON TOWN OF ADDISON STREETS:** The Contractor shall receive approval of its haul routes and type of equipment to be used prior to beginning construction. The Contractor shall be responsible for maintaining the cleanliness of existing paved roadways and shall provide equipment and manpower for that purpose.
44. **EXISTING POWER POLES & GUY WIRES:** The Contractor shall have the responsibility of coordinating with the proper authorities for the bracing, replacing or relocating of all utility poles and guy wires which interfere with the Work on this Project

Belt Line Road Underground Electrical Phase I – Marsh Lane to Midway Road

prior to beginning its construction operations. The Contractor will also be responsible for all damage to poles, guy wires, etc. that are damaged or destroyed by Contractor's operations.

45. SAFETY RESTRICTIONS - WORK NEAR HIGH VOLTAGE LINES: The following procedures shall be followed for Work near high voltage lines on this contract:

- a. A warning sign not less than five (5) inches by seven (7) inches, painted yellow with black letters that are legible at twelve (12) feet shall be placed inside and outside vehicles such as cranes, derricks, power shovels, drilling rigs, pile driver, hoisting equipment or similar apparatus. The warning sign shall read as follows: "Warning - Unlawful to Operate This Equipment Within Six Feet of High Voltage Lines."
- b. Equipment that may be operated within ten (10) feet of high voltage lines shall have an insulating cage guard protecting the boom or arm, except backhoes or dippers, and insulator links on lift hook connections.
- c. When necessary to Work within six (6) feet of high voltage electric lines, notify the power company who will erect temporary mechanical barriers, de-energize the line, or raise or lower the line. All such Work done by the power company shall be at the expense of the Contractor. The Contractor shall maintain an accurate log of all such calls to the power company.
- d. The Contractor is required to make arrangements with the power company for the temporary relocation or raising of high voltage lines at the Contractor's sole expense.
- e. No person shall Work within six (6) feet of high voltage lines without protection measures having been taken as outlined in Paragraph c.

46. PROTECTION OF EXISTING UTILITIES AND STRUCTURES: The location and dimensions shown on the Plans relative to existing utilities and subsurface structures are based on the best records and/or field information available and are not guaranteed by the Town of Addison or the Engineer to be accurate as to location and depth. It shall be the Contractor's responsibility to verify locations of adjacent and conflicting utilities sufficiently in advance of its activities in order that he may negotiate such restrictive locations with the Town of Addison of the conflicting utility and/or make local adjustments to provide adequate clearances. The Contractor shall take all necessary precautions in order to protect all utilities and services encountered, whether or not they are indicated on the Plans. All damage to utilities resulting from Contractor's operations shall be restored at its expense. The Town of Addison and the Engineer assume no responsibility for failure to show any or all of these utilities or structures on the Plans, or to show them in their exact locations. It is mutually agreed that such failure shall not be considered sufficient basis for claims for additional compensation for Extra Work or for increasing the pay quantities in any manner whatsoever, unless the obstruction encountered is such as to necessitate changes in the lines or grades, or requires the

Belt Line Road Underground Electrical Phase I – Marsh Lane to Midway Road

building of special Work, provisions for which are not made in the Plans, in which case, provisions in these Specifications for Extra Work shall apply.

47. **PUBLIC UTILITIES AND OTHER PROPERTY TO BE CHANGED:** In case it is necessary to change or move the property of a public utility, such property shall not be moved or interfered with until authorized by the Town of Addison or the Engineer. The right is reserved for the Owner of public utilities to enter upon the limits of the Project for the purpose of making such changes or repairs of their property that may be made necessary by performance of the Contract. The Contractor shall be responsible for coordination with the Town of Addison and the Engineer, and all utility companies whose utility lines or streets may be affected by the proposed improvements. The Contractor shall observe the following:
- a. Prior to any excavation, the Contractor shall determine the locations of all existing water, gas, sewer, electric, telephone, telegraph, television, pipelines and other underground utilities and structures.
 - b. After commencing Work, the Contractor shall use every precaution to avoid interference with existing underground and surface utilities and structures, and protect them from damage.
 - c. Where the locations of existing underground and surface utilities and structures are indicated, these locations are generally approximate, and all items which may be encountered during the Work are not necessarily indicated. The Contractor shall determine the exact locations of all items indicated, and the existence and locations of all items not indicated.
 - d. The Contractor shall repair or pay for all damage caused by its operations to all existing utility lines, public property, and private property, whether it is below ground or above ground, and he shall defend and settle in total the cost of all lawsuits which may arise as a result of its operations.
 - e. To avoid unnecessary interferences or delays, the Contractor shall coordinate all utility removals, replacements and construction with the appropriate utility company, and then request written authorization from the Town of Addison or the Engineer. The Town of Addison and the Engineer will not be liable for damages due to delay as a result of the above.
48. **MAINTENANCE AND REPAIRS:** The Contractor shall maintain and keep in good repair all Work contemplated under these Plans, Specifications, and Plans which shall include the maintenance and repair of all existing streets, storm sewer crossings, utility crossings, temporary crossings for access to adjacent property, barricades, lights, and danger signals, and all Work which is necessary for the well being of the general public. In the event the Contractor fails in its obligations to properly maintain the Work, the Town of Addison shall make such repairs as are necessary and the cost of such repairs shall be deducted from payment due the Contractor.

Belt Line Road Underground Electrical Phase I – Marsh Lane to Midway Road

49. **PROTECTION OF WORK:** During performance and up to date of final acceptance, the Contractor shall be under the absolute obligation to protect the finished Work against damage, loss or injury. In the event of damage, loss or injury, the Contractor shall promptly replace or repair such Work, whichever the Town of Addison shall determine to be preferable. The obligation to deliver finished Work in strict accordance with the contract prior to final acceptance shall be absolute and shall not be affected by the Town of Addison's approval of or failure to prohibit means and methods of construction used by the Contractor. All risk of loss or damage to the Work shall be borne solely by the Contractor until final acceptance of all Work by the Town of Addison, as evidenced by the Town of Addison's issuance of a certificate of acceptance.

50. **PUBLIC CONVENIENCE AND SAFETY:** In accordance with generally accepted construction practices, the Contractor shall be solely and completely responsible for conditions of the Project site, including safety of all persons and property during performance of the Work. This requirement shall apply continuously and not be limited to normal Work hours.

Materials stored about the Work site shall be so placed, and the Work shall at all times be so conducted, as to cause no greater obstruction to the traveling public than is considered necessary by the Town of Addison. The materials excavated shall be placed so as not to endanger the Work or prevent free access to all fire hydrants, water valves, gas valves, manholes (telephone, telegraph or electrical conduits, and sanitary sewers) and fire alarm or police call boxes in the vicinity.

The Town of Addison reserves the right to remedy any neglect on the part of the Contractor as regards to the public convenience and safety which may come to the Town of Addison's attention, after 24 hours notice in writing to the Contractor, save in cases of emergency, when the Town of Addison shall have the right to remedy any neglect without notice; and, in either case, the cost of such Work done by the Town of Addison shall be deducted from the monies due or to become due the Contractor. The Contractor shall notify the Town of Addison and the Engineer when any street is to be closed or obstructed. The Contractor shall provide for emergency vehicle access at all times.

Where the Work passes over or through private property, the Town of Addison shall provide such right-of-way. The Contractor shall notify the proper representatives of any public utility, corporation, company or individual, not less than 48 hours in advance of Work which might damage or interfere with the operation of their property along or adjacent to the Work. The Contractor shall be responsible for all damage or injury to property of any character (except such as may be required by the provisions of the Contract Documents, or caused by agents or employees or the Town of Addison) by reason of any negligent act or omission on the part of the Contractor, its employees, agents or Subcontractors, or at any time due to defective Work or materials, or due to its failure to reasonably or properly prosecute the Work, and said responsibility shall not be released by the fact that the Work shall have been completed and accepted.

Belt Line Road Underground Electrical Phase I – Marsh Lane to Midway Road

When and where any such damage or injury is done to public or private property on the part of the Contractor, he shall restore or have restored at its own cost and expense such property to a condition similar or equal to that existing before such damage was done, by repairing, rebuilding or otherwise restoring as he may be directed, or he shall make good such damage or injury in a manner acceptable to the property Town of Addison and the Engineer. In case of failure on the part of the Contractor to restore such property or make good such damage or injury, the Town of Addison may, upon 48 hour written notice under ordinary circumstances, and without notice when a nuisance or hazardous condition results, proceed to repair, rebuild or otherwise restore such property as may be determined necessary, and the cost thereof shall be deducted from any monies due or to become due to the Contractor under this contract; or where sufficient contract funds are unavailable for this purpose, the Contractor or its surety shall reimburse the Town of Addison for all such costs.

51. **PROTECTION OF PERSONS AND PROPERTY:** The Contractor shall have the responsibility to provide and maintain all warning devices and take all precautionary measures required by law or otherwise necessary to protect the Work and persons and property while said persons or property are approaching, leaving or within the Work site or any area adjacent to said Work site. No separate compensation shall be paid to the Contractor for the installation or maintenance of any protective measures, warning devices, barricades, lights, signs, or any other precautionary measures required by law or otherwise necessary for the protection of persons or property.

The Contractor shall assume all responsibilities to the general public in connection with the general public's immediate approach to and travel through the Work site and the area adjacent to said Work site.

Where the Work is in or adjacent to any street, alley, sidewalk, public right-of-way or public place, the Contractor shall at its own cost and expense provide such flagmen and watchmen and furnish, erect and maintain such warning devices, barricades, lights, signs, and other precautionary measures for the protection of persons or property as may be prudent or necessary, or as required by law. The Contractor's responsibility for providing and maintaining flagmen, watchmen, warning devices, barricades, signs and lights and other precautionary measures shall not cease until the Project shall have been completed and accepted by the Town of Addison, and shall cease when the Town of Addison notifies the Contractor in writing of final Project acceptance.

If the Town of Addison discovers that the Contractor has failed to comply with applicable federal or state laws (by failing to furnish the necessary flagmen, warning devices, barricades, lights, signs or other precautionary measures for the protection of persons or property), the Town of Addison may order the Contractor to take such additional precautionary measures as required by law to protect persons and property. In addition, the Contractor shall be held responsible for all damages to the Work and other public or private property due to the failure of warning devices, barricades, signs, lights or other precautionary measures in protecting said property; and whenever evidence is found of

Belt Line Road Underground Electrical Phase I – Marsh Lane to Midway Road

such damage, the Town of Addison may order the damaged portion immediately removed and replaced by and at the cost and expense of the Contractor.

52. TRAFFIC CONTROL: It shall be the responsibility of the Contractor to provide traffic control during the construction as required by the State of Texas, the Town of Addison, and in accordance with the following additional requirements:

- a. The Contractor shall be required to furnish barricades, flares, flagmen, etc., for the protection of the public, employees and the Work.
- b. The Contractor shall prosecute its Work in such a manner as to create a minimum of interruption to traffic along adjacent roadways.
- c. The unit price bid under the appropriate bid item of the proposal shall cover all cost for providing signage, markings, lighting, barricades, flagmen and other devices and personnel required for traffic control during construction of the Project.
- d. The Contractor shall not remove any regulatory sign, instructional sign, warning sign, street name sign or any other sign or signal which currently exists.
- e. The Contractor shall provide a comprehensive Traffic Control Plan to the Town of Addison and Engineer for review, comment, and approval in the event the planned sequence of work is different in any way from that sequence of work provided for in the plans or where additional details are required. The Traffic Control Plan shall be designed in accordance with established standards and regulations and signed and sealed by a professional engineer, registered in the State of Texas. The plan should reflect the Contractor's proposed construction phasing and methodology and include the design layout for all proposed detour and traffic situations.

53. BARRICADES, WARNING SIGNS, DETOURS AND SEQUENCE OF CONSTRUCTION: Throughout the construction operations, streets and intersections will remain open to traffic by constructing the Work in stages. All streets, driveways, adjacent business and alleys shall remain open to traffic as far as is practicable.

A. General Construction: The Contractor shall plan its Work sequence in a manner that will cause minimum interference with traffic during construction operations. Before beginning Work on this Project, the Contractor shall submit, for approval by the Town of Addison, a plan of construction operations outlining in detail a sequence of Work to be followed; setting out the method of handling traffic on streets, roads and driveways along, across and adjacent to the Work. If at any time during the construction, the Contractor's proposed plan of operation for handling traffic does not provide for safe comfortable movement, the Contractor shall immediately change its operations to correct the unsatisfactory conditions.

Ditches across the traffic lanes will be kept covered with a portable traffic-bearing surface at all times unless Work in the ditch is in progress. Only one lane of traffic may be closed at a time when Work is in progress in a ditch.

Belt Line Road Underground Electrical Phase I – Marsh Lane to Midway Road

B. Safety: The Contractor shall provide, construct and maintain barricades and signs at locations set out in the Plans and in the Special Provisions in accordance with the Texas Manual on “Uniform Traffic Control Devices for Streets and Highways”. In addition, he shall provide and maintain such other barricades and signs as deemed necessary by the Town or the Engineer, and provide and maintain, between sunset and sunrise, a sufficient number of lights at barricades and points of danger for the protection of vehicular and pedestrian traffic.

Barricades shall be placed in such a manner as not to interfere with the sight distance of drivers entering the street from side streets.

The Contractor shall keep traveled surfaces used in its hauling operation clear and free of dirt or other material.

The Contractor shall provide and maintain qualified flagmen at such points and for such periods of time as may be required to provide for the safety and convenience of public travel and Contractor’s personnel.

54. EXCAVATION SAFETY SYSTEMS:

The Work performed under this section of the Specifications consists of providing trench safety systems consisting of shoring, sheeting, trench shield, and/or laid back slopes to meet the trench safety requirements of the Occupational Safety and Health Administration (O.S.H.A.), as required for this Project and specified herein.

A. General: Trench safety systems shall be provided by the Contractor as provided in Subpart P - Excavation, Trenching and Shoring, Part 1926 of the Code of Federal Regulations which describes safety and health regulations as administered by the U.S. Department of Labor Occupational Safety and Health Administration (O.S.H.A.). The standards specified by the O.S.H.A. Regulations shall be the minimum allowed on this Project. It shall be the responsibility of the Contractor to design and install adequate trench safety systems for all trenches excavated on this Project.

The Contractor shall furnish to the Town for review, prior to beginning construction activity, a Trench Safety Plan for the entire Project. The trench safety plan must be prepared and sealed by a Professional Engineer registered in the State of Texas. In addition, all trench safety systems utilized in this Project must be designed by a Professional Engineer registered in the State of Texas. The Contractor shall be totally responsible for the safety of all persons involved in the construction of this Project.

B. Core Borings: Any core borings and soil data furnished by the Town are for the convenience of the Contractor. The Contractor shall be responsible for any additional soil or geotechnical information required. The Contractor shall be responsible for properly designed trench safety systems to be utilized for any type of subsurface condition found on this Project. The furnishing of soil information by the Town of Addison in no way relieves the Contractor of this obligation. If no core borings or soil

Belt Line Road Underground Electrical Phase I – Marsh Lane to Midway Road

data are furnished by the Town, it shall be the Contractor's responsibility to obtain whatever geotechnical information required for preparation of trench safety systems.

C. Inspections: In addition to the inspections of the trench and trench safety systems required of the Contractor by the O.S.H.A. Regulations, the Town may further inspect the Work. The Town shall have the right to reject any trench safety systems which he finds to be inadequate, and the Contractor shall immediately improve the system to comply with this specification.

D. Measurement and Payment: Measurement and payment of Trench Safety Systems shall be based on the actual linear footage of the pipe installed on the Project. The payment shall be full compensation for all planning, engineering, materials, equipment, fabrications, installation, recovery and all incidental Work required. All excavation and backfill in addition to that specified elsewhere in these Specifications shall be considered subsidiary to this bid item.

55. TRENCH EXCAVATION, BACKFILL AND COMPACTION: Trench excavation, backfill and compaction of storm drain and utility trenches shall be in accordance with Town of Addison Standards and with details shown on the Construction Plans.

A. Trench Excavation: If the stated maximum trench widths are exceeded, either through accident or otherwise, and if the Engineer determines that the design loadings of the pipe will be exceeded, the Contractor will be required to support the pipe with an improved trench bottom. The expense of such remedial measures shall be entirely the Contractor's own. All trenching operations shall be confined to the width of permanent rights-of-way, permanent easements and any temporary construction easements. All excavation shall be in strict compliance with the Trench Safety Systems Special Condition of this document.

B. Trench Backfill: Trenches shall be backfilled above the top of the embedment material with approved backfill material per Town of Addison Standards for the appropriate pipe size, pipe material, depth, and soil condition.

C. Compaction: All trenches under proposed or existing pavement shall be compacted to within a range of 95% to 100% Standard Proctor Density. Trenches which lie outside limits of pavement shall be compacted to a minimum of 90% Standard Proctor Density (ASTM D-698).

56. TRENCH WALLS: The Contractor shall use shoring or a drag box in those areas where it is required to protect existing improvements. This shall be subsidiary to the linear foot cost of the pipe and not a separate pay item.

57. SUSPENSION OF WORK RELATED TO DANGER: In addition to the other remedies for suspension of the Work as provided for in the General Provisions and Special Provisions, the Town of Addison has the authority to suspend all work immediately if, in the Town of Addison's opinion, there is imminent danger to workers or the general public. If there is no imminent danger to workmen or the general public, but

Belt Line Road Underground Electrical Phase I – Marsh Lane to Midway Road

trench conditions are not in compliance with Federal Regulations 29 C.F.R. 1926.650-1926.652, the Town of Addison shall warn the Contractor who shall then immediately order all workmen in and adjacent to the trench away from the area. The Contractor must then bring the trench into compliance with the regulations. If the Contractor does not make the required corrections, all work on the Contract shall cease and the Town of Addison will issue a letter of Temporary Suspension of Work. The only work authorized after issuance of this letter is work approved by the regulations. Other work shall not be permitted until the Town of Addison issues a letter of Release of Temporary Suspension of Work. The Contractor shall not be entitled to additional compensation, an extension of time or payment of damages as a result of a temporary suspension of work under this provision.

58. **PROPERTY LINES AND MONUMENTS:** The Contractor shall protect all property corner markers, and when any such markers or monuments are in danger of being disturbed, they shall be properly referenced and if disturbed shall be reset at expense of the Contractor.
59. **CONSTRUCTION STAKING:** Construction staking will not be provided by the Town of Addison or Engineer. This item will be performed by the Contractor and shall be subsidiary to other bid items. The Contractor will also be responsible for maintaining stakes. If re-staking is required for any reason, it will be the Contractor's responsibility, including associated costs.

All construction staking shall be done under the supervision of a Registered Professional Land Surveyor registered in the State of Texas. The Contractor shall submit copies of cut sheets and field books for the construction of all paving, water, wastewater, and stormwater improvements to the Town of Addison for review prior to construction of the improvements. The information on the cut sheets and field books shall include but not be limited to the following:

- a. Heading to include date, contract number, Project name, surveying firm, Contractor, and construction plan sheet number.
- b. Location, description of street/line and street/line name, number, letter, etc. designation.
- c. Benchmark Data: Location, description, and elevation.
- d. Slope or percent of grade of each curb line or utility line.
- e. Stations at 50 foot intervals and including all PC, PT, PI, PVC, PVI, PVT, PRC, grade changes, etc.
- f. Offset description including distance to center line or back of curb and direction of offset; left, right, east, west, etc,
- g. Cut to subgrade, pavement, top of curb, or flowline of the street or utility being staked.

Belt Line Road Underground Electrical Phase I – Marsh Lane to Midway Road

- h. Clarifying remarks such as top of curb, gutter, pavement, subgrade, manhole, cleanout, valve, tee, cross, fire hydrant, wastewater lateral, water service, etc.
 - i. Cut sheets shall be signed by a Texas Registered Professional Land Surveyor.
60. **VENDOR'S CERTIFICATION:** All materials used in construction shall have a vendor's certified test report. Test reports shall be delivered to the Engineer before permission will be granted for use of the material. All vendors' test reports shall be subject to review by the Engineer, and shall be subject to verification by testing of samples of materials as received for use on the Project. In the event additional tests are required, they shall be performed by an approved independent testing laboratory and shall be paid for by the Contractor.
61. **WATER PIPE:** All water mains twelve-inch (12") diameter and smaller shall be AWWA C-900 PVC pressure pipe with cast iron o.d. or when pipe penetrates meter vault walls it shall be ductile iron. Pipe joints shall be rubber ring and integral thickened bell, assembled with a factory supplied lubricant. Water mains shall have a minimum class rating of 165-psi for domestic use and a minimum class rating of 235-psi for fire line applications. Joint material for PVC shall conform to ASTM F471.
62. **WASTEWATER PIPE:** All wastewater main piping shall meet the extra strength requirements of ASTM specification D3034 (SDR-35). Pipe shall have the bell and spigot type joints, consisting of integral wall section with factory installed compression rubber ring gasket, securely locked in bell groove to provide positive seal under all installation conditions. Pipe shall be laid with the bell end on the upstream side.
63. **STORM DRAINAGE PIPE:** All pipe for storm drainage improvements shall be reinforced concrete pipe (RCP), Class III, unless otherwise noted on the Plans.
64. **POLYETHYLENE WRAPPING:** All valves, ductile iron pipe, cast iron fittings, and specials, shall be polyethylene wrapped. Payment for the polyethylene wrapping for these components shall be subsidiary to the various items bid for the furnishing and installing pipe complete in place. Polyethylene wrap shall precede blocking.
65. **PIPE CLEANING:** Joints shall be wiped and then inspected for proper installation by the inspectors. Each joint shall be swept daily and kept clean during installation. A temporary night plug shall be installed on all exposed pipe ends during any period of Work stoppage.
66. **PLUGS:** Pipe plugs for water and wastewater lines shall be considered incidental and shall not be a separate pay item. Plugs for storm drain lines do have separate pay items established for each size provided and shall be paid for accordingly.
67. **CEMENT STABILIZED BACKFILL:** Two (2) sack cement stabilized backfill shall be provided in wastewater pipe trenches at locations of crossings with water lines where shown on the Plans and in conformance with Texas Commission on Environmental Quality (TCEQ) for Public Water Systems. Payment for such Work including all labor,

Belt Line Road Underground Electrical Phase I – Marsh Lane to Midway Road

tools, equipment and material necessary to complete the Work shall be included in the linear foot price bid for Cement Stabilized Backfill.

68. **NON-METALLIC WATER PIPE DETECTION:** Detectable underground utility warning tapes, which can be located from the surface by a pipe detector, shall be installed directly above non-metallic pipe. The detectable tape shall be “Detect Tape” as manufactured by Allen Systems, Inc. or an approved equal, and shall consist of a minimum thickness of 0.35-mil. Solid aluminum foil encased in a protective inert plastic jacket that is impervious to all known alkalis, acids, chemical reagents and solvents found in the soil. The minimum overall thickness of the tape shall be 5.5-mils. And the width shall not be less than two-inch with a medium unit weight of 2 ½ pounds per inch x 1,000 feet. The tape shall be color coded and imprinted with the messages as follow:

<u>Type of Utility</u>	<u>Color Coded</u>	<u>Legend</u>
Water	Safety Precaution Blue	CAUTION BURIED WATER LINE BELOW
Sanitary	Safety Green	CAUTION BURIED SEWER LINE BELOW

Installation of detectable tapes shall be per manufacturer’s recommendations, and shall be as close to the grade as is practical for optimum protection and detectability. Allow a minimum of 18 inches between the tape and the water line. Payment for detectable tapes shall be included in the linear foot price bid for applicable pipe(s).

69. **PIPE EMBEDMENT:** All storm drain and utility construction shall be installed with embedment per the details shown on the Plans for the appropriate pipe size, pipe material, depth and soil condition unless otherwise directed by the Town of Addison or the Engineer.

70. **REMOVALS, ADJUSTMENTS AND REPLACEMENTS:** Existing pavements, driveways, curbs, gutters, sidewalks, etc., to be demolished and removed to facilitate the construction of the improvements shall be broken up and disposed of. Care shall be exercised to leave a neat, uniform edge or joint at the excavation limits or sections removed where only portions are to be removed. The Engineer will designate the limits to be removed. Where pavements, driveways, curbs, gutters, sidewalks, etc., shall be replaced, then said replacements shall be to the standard of the previously removed portion or better. Re-sawing of damaged edges will be at the Contractor’s expense.

Existing structures such as manholes, inlets, cleanouts, valve boxes, etc. which are not the property of a private firm or company, or an individual required to move their own property, shall be adjusted, altered or reset to the required elevation and alignment. New materials and workmanship necessary shall conform to the requirements of these Specifications covering the particular Work. Salvaged materials in good condition may be used in rebuilding such structures, provided the materials are thoroughly cleaned

Belt Line Road Underground Electrical Phase I – Marsh Lane to Midway Road

before their use. These items shall be subsidiary to other bid items unless quantified in the proposal as a separate bid item.

All private obstructions which are indicated on the Plans to be moved, will be removed and replaced, or moved to new permanent locations by the Contractor, without additional payment to the Contractor. Any such additional item which the Contractor moves or causes to be moved for its own convenience shall be at its own expense.

71. **PAVEMENT REPAIR:** The unit price bid under the appropriate bid item of the proposal shall cover all cost for providing pavement repair per the pavement repair detail provided in the Plans.
72. **PAVEMENT REMOVAL AND REPLACEMENT:** The Contractor will be responsible for any pavement that is damaged or destroyed by the Contractor's operations. Concrete street or sidewalk repair shall be full panel replacement to the standard of the previously removed portion or better. In the event the Contractor fails in its obligations to properly repair the Work in a timely manner, the Town of Addison shall make such repairs as are necessary and the cost of such repairs shall be deducted from payment due the Contractor.
73. **WATER FOR CONSTRUCTION:** The Contractor shall acquire a meter and make the necessary arrangements with the Town of Addison for securing and transporting all water required for construction, including water required for mixing of concrete, sprinkling, testing or flushing. There will be no separate pay item for connection into the existing water system and quantity of water required for construction purposes. The Town of Addison will furnish water for initial cleaning and sterilization of water lines. All additional water used by the Contractor for compaction or any other purpose incidental to this Project may be obtained from existing hydrants along adjacent roadways. Note that the Contractor will be responsible for supplying chlorine gas or chlorinated lime (HTH) for water line sterilization.
74. **EXISTING STOCKPILES OF MATERIAL ON SITE: N/A**
75. **BORROW SOURCE:** If additional sources of earthen material are required for construction of embankment areas to complete the Project to the alignment, grades and cross sections indicated on the Plans, Contractor will be required to locate, obtain, excavate, deliver and place suitable fill material from an off-site source. Borrow materials should be compatible with existing on-site materials and shall be tested by the Geotechnical Engineer (employed and paid for by the Town of Addison) for acceptance as an approved source of borrow prior to borrow operations. Item 3.6 - Borrow of the Standard Specifications for Public Works Construction, North Central Texas Council of Governments shall apply for all Work performed.
76. **EXCESS MATERIAL:** Suitable excess material (if any) may be disposed of on this site at locations directed by the Engineer. Topsoil shall be stripped and stockpiled from locations where excess material is to be placed. The Contractor shall scarify the spoil area to a depth of 6 inches and shall place the spoil material in 6-inch lifts, compacted to

Belt Line Road Underground Electrical Phase I – Marsh Lane to Midway Road

ninety-five percent (95%) of the maximum density as determined by ASTM D-698 Standard Proctor Test Method at or slightly above optimum moisture content.

Rock shall be broken or crushed so that the maximum dimension is 2” for use. No rock larger than 2” will be allowed in the upper 12” of fill. After completion of filling, replace topsoil and smooth grade.

Tree stumps and limbs, concrete debris, discarded materials and all unsuitable excess spoil material, including rock measuring larger than 12” in the largest dimension, shall become the property of the Contractor and shall be removed from the site and disposed of by the Contractor at its expense. The Contractor shall also comply with all applicable laws governing spillage of debris while transporting to a disposal site, and shall indemnify and save harmless the Town of Addison and the Engineer from all suits, actions, or claims of any character resulting from its arrangements for the disposal of spoil.

77. **DURING CONSTRUCTION:** During construction of the Work, the Contractor shall, at all times, keep the site of the Work and adjacent premises as free from material, debris and rubbish as is practicable and shall remove same from any portion of the site if, in the opinion of the Town of Addison or the Engineer, such material, debris or rubbish constitutes a nuisance or is objectionable. In case of failure on the part of the Contractor to maintain a clean site, the Town of Addison may, upon 24 hour written notice, clean the site, and the cost thereof shall be deducted from any monies due or to become due to the Contractor under its contract; or where sufficient contract funds are unavailable for this purpose, the Contractor or its surety shall reimburse the Town of Addison for all such costs.

78. **CONSTRUCTION TRAFFIC OVER PIPE LINES:** The design of the new pipes and the design of the existing pipe have been taken into account and provided for highway live loads. It is apparent, however, that certain construction vehicles could exceed this highway load condition under shallow bury conditions. It will be the responsibility of the Contractor to protect both the new line and the existing lines from these possibly excessive loads. The Contractor shall not at any time cross the existing or new pipe with a truck delivering new pipe to the site. Any damage to the existing or new pipe will be repaired or replaced by the Contractor to the satisfaction of the Town of Addison.

In locations where it is not permissible to cross the existing or proposed pipes without additional protection, the Contractor may elect to provide additional protection of the pipes so that more frequent crossings of the pipes are allowed. It still is, however, the responsibility of the Contractor to repair any damage to the existing or proposed lines if the damage results from any phase of its construction operation.

79. **CONTRACTOR’S CONTINUING OBLIGATION:** Contractor’s obligation to perform and complete the Work in accordance with the Contract Documents shall be absolute. Neither recommendation of any progress or final payment by the Town of Addison, nor the issuance of a certificate of Substantial Completion, nor any payment by Town of Addison to Contractor under the Contract Documents, nor any use or occupancy

Belt Line Road Underground Electrical Phase I – Marsh Lane to Midway Road

of the Work or any part thereof by Town of Addison, nor any act of acceptance by Town of Addison nor any failure to do so, nor any review and approval of a Shop Drawing or sample submission, nor the issuance of a notice of acceptability by the Town of Addison pursuant to final payment nor any correction of defective Work by Town of Addison will constitute an acceptance of Work not in accordance with the Contract Documents or a release of Contractor's obligation to perform the Work in accordance with the Contract Documents.

80. **TOP SOILING, SEEDING AND FERTILIZING:** This item shall cover the topsoiling, seeding, fertilizing, watering and required maintenance for the grassing of all unpaved areas of the right-of-way and the easements, and all other areas of the Project site that have been disturbed by this Contractors' operations including batch plant site, haul roads, etc. excluding building pad sites and lots which will not require seeding and fertilizing. The pay item shall only include that area which is within the right-of-way and the easements. All other disturbed areas requiring seeding and fertilizing shall be considered subsidiary to the cost of the Project. Top soiling, seeding and fertilizing shall be provided in accordance with NCTCOG Items 202.2, 202.4 and 202.6, respectively.
81. **IRRIGATION AND SPRINKLER REPAIR:** The Contractor shall maintain all existing irrigation systems within the limits of the Project during the duration of the contract. The Contractor shall employ a licensed irrigator who is responsible for the repair or replacement of any damage to irrigation lines, valves, controllers, sprinklers, wiring and appurtenances which are damaged during construction. This repair is subsidiary to the various other items bid. The Contractor will be responsible for any vegetation that dies as a result of damage to the irrigation system and replace it with equal vegetation at its own cost.
82. **REMOVAL OF DEFECTIVE AND UNAUTHORIZED WORK:** All Work which has been rejected or condemned shall be repaired; or if it cannot be repaired satisfactorily, it shall be removed and replaced at the Contractor's expense. Defective materials shall be immediately removed from the Work site. Work done without line and grade having been provided; Work done beyond the line or not in conformity with the grades shown on the Plans or as provided, Work done without proper inspection; or any Extra or unclassified Work done without written authority and prior agreement in writing as to prices, shall be at the Contractor's risk and will be considered unauthorized, and at the option of the Town of Addison may not be measured and paid for and may be ordered removed at the Contractor's expense. Upon failure of the Contractor to repair satisfactorily or to remove and replace, if so directed, rejected, unauthorized or condemned Work or materials immediately after receiving notice from the Town of Addison, the Town will, after giving written notice to the Contractor, have the authority to cause defective Work to be remedied or removed and replaced, or to cause unauthorized Work to be removed and to deduct the cost thereof from any monies due or to become due the Contractor.
83. **DISPOSITION AND DISPOSAL OF MATERIALS:** All materials to be removed from the site including refuse and other debris shall become the property of the Contractor and shall be disposed of outside the limits of the Project. Contractor shall also

Belt Line Road Underground Electrical Phase I – Marsh Lane to Midway Road

comply with all applicable laws governing the spillage of debris while transporting to a disposal site.

84. **CLEAN-UP FOR FINAL ACCEPTANCE:** The Contractor shall make a final cleanup of all parts of the Work before acceptance by the Town of Addison. This cleanup shall include removal of all objectionable rock and other construction materials, and in general preparing the site of the Work in an orderly manner and appearance.
85. **TV INSPECTION OF SANITARY SEWER AND STORM DRAIN SYSTEMS:** Part of the final inspection of the wastewater and storm drain systems on this Project shall include a closed circuit TV survey of the completed pipe installation, exclusive of services, and all imperfections in the installed facility revealed by the TV survey of the imperfections in the installed facilities revealed by the TV survey shall be remedied by the Contractor prior to acceptance of the Project as complete. All TV survey Work, including furnishing of necessary personnel, equipment and material shall be performed by the Contractor.
86. **MATERIALS TO BE FURNISHED BY AT&T, TWC and FIBERLIGHT:** **FIBERLIGHT ONLY will provide limited appurtenances necessary for the construction of the telephone duct bank system. Appurtenances shall include manholes and pull boxes. The appurtenances will be delivered to the project site for this contractor's use in constructing the duct bank system to franchise utilities standards and specifications. The unit price cost in this proposal shall include all labor and associated costs for construction of the duct bank system including conduits, trenching, concrete, rebar, embedment, placement of the appurtenances supplied by franchise utilities, trench backfilling and any related work.**
87. **TESTING REQUIREMENTS:** Testing shall be conducted in accordance with Town of Addison Specifications except as modified in the Special Provisions, Technical Specifications, or as on the plans. The Town of Addison will provide random testing. The Contractor shall coordinate construction with the Town of Addison, and shall provide assistance to the testing labs by providing trench safety, excavation, or other work to insure all testing requirements are met. Work performed to accommodate testing will be a subsidiary item and no extra payment will be authorized. All retesting shall be at the expense of the Contractor. As a general guide, the Contractor shall be responsible for providing the following tests:
- (1) Density and associated tests on embedment and backfill.
 - (2) Compressive strength tests on concrete.
 - (3) Gradation soil tests on backfill as may be required.
 - (4) Providing test results from manufacturer as specified in Town of Addison Specifications.
88. **SILICONE JOINT SEALANT:** Silicone joint sealant must be used in all instances where joint sealant applies to Portland Cement Concrete pavement and curbs. Payment

Belt Line Road Underground Electrical Phase I – Marsh Lane to Midway Road

for the use of silicone joint throughout this Project will in all cases be subsidiary to this contract at no extra cost.

89. **CLAIMS FOR DAMAGES OR INJURY:** General Provision Item 1.24.3 - SMALL CLAIMS FOR DAMAGE OR INJURY is amended to read as follows: “If any person files a claim against the Town of Addison or Contractor for personal injury or property damage resulting from, arising out of, or caused by, the operations of the Contractor, or any Work within the limits of the Project, the Contractor must either submit to the Town of Addison, a duly executed full release within thirty (30) days from the date of written claim, or immediately report the claim to its liability insurance carrier for their action in adjusting the claim. If the Contractor fails to comply with this provision within the stipulated time limit, it will be automatically deemed that the Contractor has appointed the Town as it’s irrevocably Attorney-In-Fact authorizing the Town to report the claim directly with the liability insurance carrier. This provision is in and of itself a Power-of-Attorney from the Contractor to the Town which authorizes the Town to take said action on behalf of the Contractor without the necessity of the execution of any other document. If the Contractor fails to comply with the provisions of this item the Town, at its own discretion, may terminate this contract or take any other actions it deems appropriate. Any payment or portion thereof due the Contractor, whether it is a final payment, progress payment, payment out of retainage or refund payment may be withheld by the Town as is authorized by Item 109.4. Bankruptcy, insolvency or denial of liability by the insurance carrier shall not exonerate the Contractor from liability.

As a result of the additional Work created to Town of Addison due to un-responded claims for damages by Contractor to third parties, Contractor shall incur penalties for failure to abide by this Special Provision.

Contractor shall respond to the claimant in writing regarding the status of the claim, including whether Contractor disputes the claim, wishes to settle, or will notify its liability insurance carrier regarding the claim. Contractor will be assessed a penalty by the Town of \$75.00 per claim, for its failure to respond to the claimant as described above within thirty days of its written notice of claim by the Town.

To ensure Contractor compliance, the Town of Addison shall be notified, by copied correspondence of responses or settlement by Contractor.”

90. **WAIVER OF CLAIMS:** The making and acceptance of final payment will constitute:
- A. A waiver of all claims by Town of Addison against Contractor, except claims arising from unsettled Liens, from defective Work appearing after final inspection or failure to comply with the Contract Documents or the terms of any special guarantees specified therein; however, it will not constitute a waiver by Town of Addison of any rights in respect of Contractor’s continuing obligations under the Contract Documents.
 - B. A waiver of all claims by Contractor against Town of Addison other than those previously made in writing and still unsettled.

Belt Line Road Underground Electrical Phase I – Marsh Lane to Midway Road

91. **MECHANICS AND MATERIALMEN'S LIEN:** The Contractor shall be required to execute a release of mechanics and materialmen's liens upon receipt of payment and shall ensure that the Project remains free and clear of all liens related to the Work. The Contractor shall have all liens removed by obtaining releases acceptable to the Town of Addison or shall bond around such liens by obtaining a discharge of all liens.
92. **CONTRACTOR'S AFFIDAVIT OF BILLS PAID:** The Contractor shall be required to execute the form provided in Section BP prior to the acceptance of the Project.
93. **PRODUCT RECORD DOCUMENTS:** The Contractor shall maintain record Plans and legibly annotate shop drawings to record changes made after review. A red felt-tip marking pen shall be used for all recording.

Maintenance of Documents: The Contractor shall maintain at the job site one record copy of the Contract Plans, Specifications, Shop Drawings, Change Orders, other modification to the Contract, field test records and other documents submitted by Contractor in compliance with specification requirements. These documents shall be maintained at the job site apart from documents used for construction. These documents are not to be used for construction purposes. The documents shall be maintained in clean, legible condition. The documents shall be made available at all times for inspection by the Town.

Recording: Each document shall be labeled Project Record Copy in 2-inch high printed letters. The record documents shall be kept current. No Work shall be covered until required information has been recorded.

Contract Plans: The appropriate drawing shall be legibly marked to record, where applicable:

- a. Horizontal and vertical location of underground utilities and appurtenances referenced to permanent surface improvements.
- b. Field changes of dimension and detail made during construction process.
- c. Changes made by Change Order or Supplemental Agreement.
- d. Details not on original Contract Plans.
- e. Manufacturer, trade name, catalog number and supplier of each product and item of equipment actually installed.
- f. Changes made by Change Order or Supplemental Agreement.
- g. Other matters not originally specified.

Shop Drawing: The Contractor shall maintain the Shop Drawings as record drawings and legibly annotate shop drawings to record changes made after review.

Belt Line Road Underground Electrical Phase I – Marsh Lane to Midway Road

Submittal: At the completion of the Project, the Contractor shall deliver record Plans to the Town. The transmittal letter shall be accompanied, in duplicate, with:

- a. Date, Project title and number.
- b. Contractor's name and address.
- c. Title and number of each record document.
- d. Certification that each document as submitted is complete and accurate.
- e. Signature of Contractor or its authorized representative.

94. **OWNERSHIP OF WORK AND MATERIALS:** All Work performed by Contractor pursuant to the Contract shall be the property of the Town of Addison. The Town of Addison shall own all construction, and any data, documents, plans, specifications, working papers, computer programs, photographs, or other material produced by Contractor pursuant to the Contract, and Contractor hereby assigns and transfers to the Town of Addison any and all copyrights for such material. To the extent that such programs used are internal, proprietary programs used by Contractor in the performance of the Work, Contractor will provide the Town of Addison such access to the programs as is necessary for the Town of Addison to be able to use the products and documents generated by the program, but Contractor is not required to transfer the copyrights or other intellectual property rights to the program to the Town of Addison. As security for partial, progress, or other payments, title to work for which such payments are made shall pass to the Town of Addison at the time of the payment. To the extent that title has not previously been vested in the Town of Addison by reason of payments, full title shall pass to the Town of Addison at delivery of the Work at the location specified in the Contract.

Unincorporated Work to which the Town of Addison has received title by reason of progress, partial or other payments shall be segregated from other Contractor or Subcontractor materials and clearly identified as the Town of Addison property. The Contractor shall be responsible for all materials until they have been incorporated into the Work and the Work has been finally accepted by the Town of Addison. The title transferred as above shall in each case be good, and free and clear of any and all security interests, liens, or other encumbrances. The Contractor promises and agrees that it will not pledge, hypothecate, or otherwise encumber the items in any way that would result in any lien, security interest, charge, or claim upon or against said items. The transfer of title as provided above shall not imply acceptance by the Town of Addison, nor relieve Contractor from the responsibility to strictly comply with the Contract, and shall not relieve Contractor of responsibility for any loss of or damage to such items.

The Contractor shall insert provisions in its subcontracts sufficient to ensure compliance with the content of this Section.

95. **DRAWINGS AND OTHER DATA:** All documents developed by Contractor in the performance of the Contract shall become the sole property of the Town of Addison and may be used by the Town of Addison on any other project without additional

Belt Line Road Underground Electrical Phase I – Marsh Lane to Midway Road

compensation to Contractor. Use by the Town of Addison of these documents on other projects does not confer any liability on Contractor.

The Town of Addison shall be considered the “person for whom the work was prepared” for the purpose of authorship in any copyrightable work under 17 U.S.C. § 201(b). With respect thereto, Contractor agrees not to assert or authorize others to assert any rights or establish any claim under the design related patent and copyright laws. All design drawings, as-built drawings and specifications, in any form, shall contain a copyright mark of the Town of Addison.

96. **TOWN OF ADDISON APPROVAL:** This Project is subject to final approval and acceptance by the Town of Addison. Final approval acceptance will not be given until the punch list items are completed to the Town’s satisfaction and as-built Plans are given to the Town of Addison.
97. **USE OF EXPLOSIVES:** The use of explosives by the Contractor to complete the Work shall be prohibited.
98. **POWER FOR CONSTRUCTION:** The Contractor shall contract with the local power provider and make the necessary arrangements for securing power required for the construction, including power required for temporary offices. There will be no separated pay item for connection into the existing power system or for the power required for construction purposes.
99. **LIQUIDATED DAMAGES:** If the Contractor fails to complete the Work within the time specified in the contract, the Contractor shall pay liquidated damages to the Town of Addison in the amount of \$ 1,000 for each calendar day of delay until the Work is completed or accepted.
100. **CONTRACT DELAY:** The parties anticipate that delays may be caused by or arise from any number of events during the course of the Contract, including, but not limited to, Work performed, disruptions, permitting issues, actions of subcontractors, suppliers, or other contractors, actions by third parties, weather, weekends, holidays, or other such events, forces or factors sometimes experienced in construction work. Such delays or events and their potential impacts on performance by the Contractor are specifically contemplated and acknowledged by the parties in entering into this Contract, and shall not extend the Contract time for completion. Further, any and all costs or impacts whatsoever incurred by the Contractor in accelerating the Work to overcome or absorb such delays or events in an effort to complete the Contract prior to expiration of the Contract time to complete, regardless of whether the Contractor does so or not, shall be the sole responsibility of the Contractor in every instance.
101. **SUBCONTRACTORS:** No subcontract shall relieve Contractor of any of Contractor’s obligations or liabilities under the Contract. Contractor shall be fully responsible and liable for the acts or omissions of all Subcontractors, including persons directly or indirectly employed by them, their guests and invitees. Contractor shall have sole responsibility for managing and coordinating the operations of its Subcontractors,

Belt Line Road Underground Electrical Phase I – Marsh Lane to Midway Road

including the settlement of disputes with or between them. Nothing contained in the Contract shall be deemed to create a contractual relationship between any Subcontractor, and the Town of Addison.

Contractor shall provide to the Town of Addison one (1) copy of all executed subcontracts associated with the Contract, including any changes or modifications to the subcontracts, within three (3) days of their execution. No Subcontractor shall be permitted to perform work associated with the subcontract until the Subcontractor (or Contractor on the Subcontractor's behalf) is in compliance with the insurance requirements specified elsewhere in the Contract, and has furnished satisfactory evidence of insurance to the Town of Addison.

- 102. PAYMENTS TO SUBCONTRACTORS:** Contractor shall comply with the provisions of applicable laws and regulations relating to Contractor's relations with Subcontractors. Payments by Contractor to Subcontractors associated with the Town of Addison Contracts are subject to the time periods established in the Texas "Prompt Payment Act", contained in Chapter 2251 of the Texas Government Code.

All persons employed in the performance of the Work under the Contract, or any subcontracts hereunder, shall be paid not less than the general rates of per diem, holiday, and overtime wages prevailing in the locality of the Work of a similar character as detailed in the Special Provisions. Failure to comply with this provision shall subject Contractor to the penalties prescribed in Chapter 2258 of the Texas Government Code, as amended.

Contractor will include in each subcontract for property or services entered into by Contractor and a Subcontractor, including a supplier, for purposes of performing the Work under the Contract a payment clause that obligates Contractor to pay the Subcontractor for satisfactory performance under its subcontract within seven (7) days out of such amounts as are paid to Contractor by the Town of Addison under the Contract. A false certification to the Town of Addison under the provisions of the Payments clause may be a principal offense in violation of Section 37.10 of the Texas Penal Code.

- 103. USE OF COMPLETED PORTIONS OF THE WORK:** Whenever, as determined by the Town of Addison, any portion of the Work performed by Contractor is in a condition suitable for use, and the best interests of the Town of Addison requires such use the Town of Addison may take possession of or use such portion of the Work. Such use by the Town of Addison shall in no case be construed as final acceptance, and shall neither relieve Contractor of any of its responsibilities under the Contract, nor act as a waiver by the Town of Addison of any of the conditions thereof. Contractor shall not be liable for the cost of repairs, rework, or renewals, which may be required due to ordinary wear and tear resulting from such use. However, if such use increases the cost or delays the completion of remaining portions of the Work, Contractor shall notify the Town of Addison in writing as required by the Contract and shall be entitled to such additional compensation or extension of time, or both, as determined in accordance with the Contract.

Belt Line Road Underground Electrical Phase I – Marsh Lane to Midway Road

If in the course of such use, the Work proves to not be in compliance with the Contract, the Town of Addison shall have the right to continue such use until such portion of the Work can, without injury to the Town of Addison, be taken out of service for correction of defects, errors, omissions, or replacement of unsatisfactory materials, as necessary for such portions of the Work to comply with the Contract. Contractor shall correct the Work as soon as practical, but not later than one (1) month after notification by the Town of Addison.

Contractor shall not use any permanently incorporated materials unless such use is approved in writing by the Town of Addison. Where Contractor's request is granted for the use of certain materials, Contractor shall properly use and maintain and, upon completion of its use and at its own expense, recondition such materials to the satisfaction of the Town of Addison.

104. **COMPLETE AGREEMENT:** The Contract (including Attachments, the Special Provisions, other documents and manuals incorporated herein) is the full and complete agreement between the Town of Addison and Contractor with respect to the subject matter herein and supersedes any and all prior agreements between the parties hereto.
105. **WAIVER:** The waiver by the Town of Addison of the breach of any provision of the Contract by Contractor shall in no way impair the right of the Town of Addison to enforce the provision for any subsequent breach thereof. All remedies provided hereunder are cumulative and are in addition to all other remedies available at law or in equity.
106. **EXECUTION OF THE CONTRACT:** The Contract may be executed in multiple counterparts, each of which shall, for all purposes, be deemed an original but which together shall constitute one and the same instrument, and the signature pages from any counterpart may be appended to any other counterpart to assemble fully executed documents, and counterparts of the Contract may also be exchanged via electronic facsimile machines and any electronic facsimile of any party's signature shall be deemed to be an original signature for all purposes.
107. **DEFINITIONS:** The following definitions are added to the General Provisions and Special Provisions:

BIDDER: Any person, persons, partnership, company, firm, association, or corporation acting directly or through a duly authorized representative submitting a bid for the work contemplated.

PROJECT: The Town of Addison's overall objective and endeavor of which the Contract forms a part and ultimately creates, which encompasses all Contract Documents constructed to final completion and final acceptance.

WORKING DAY: A working day is defined as a calendar day not including Saturdays, Sundays, or legal holidays authorized in the list prepared by the City of Dallas for contract purposes, in which weather or other conditions not under the control of the Contractor shall permit the performance of the principal units of work underway for a

Belt Line Road Underground Electrical Phase I – Marsh Lane to Midway Road

continuous period of not less than 7 hours between 7 A.M. and 6 P.M. A principle unit of work shall be that unit which controls completion time of the contract. Nothing in this definition shall be construed as prohibiting the Contractor from working on Saturdays, if the Contractor so desires and permission of the Town of Addison has been granted. Work on Sundays shall not be permitted except in cases of extreme emergency and then only with the written permission of the Town of Addison. If Saturday or Sunday work is permitted, working time shall be charged on the same basis as weekdays. Where the working time is expressed as calendar days or a specific date, the concept of working days shall no longer be relevant to the contract.

108. MODIFICATIONS TO THE LANGUAGE OF THE GENERAL PROVISIONS:

The General Provisions are modified as follows:

- A. Add the following words to the General Provisions before the word “Certificates” found on the fourth line of Section 103.4.1:

“When permitted by law,”

- B. Delete the sentence “A model Certificate of Insurance is illustrated in Model Form A.6 in Appendix A.” beginning on the ninth line of Section 103.4.1 of the General Provisions and replace with the following:

“Certificates of Insurance shall be provided on a state approved form.”

- C. Delete the following sentence beginning on the second line of the fifth subparagraph of Section 104.2.1 of the General Provisions:

“The foregoing notwithstanding, the total original Contract amount shall not be increased more than 25 percent; the CONTRACTOR, by submission of a bid and execution of the Contract, is deemed to consent to the OWNER’S right to reduce the total original Contract amount by more than 25 percent.”

- D. Add the following word before the word “decide” found on the second line of Section 105.7.1 of the General Provisions:

“initially”

- E. Add the following word after the word “work” found on the fifth line of Section 105.7.1 of the General Provisions:

“, subject to the agreement of the Owner”

- F. Delete the following sentence beginning on the sixth line of Section 105.7.1 of the General Provisions:

Belt Line Road Underground Electrical Phase I – Marsh Lane to Midway Road

“Engineer shall determine the amount and quality of work performed and materials furnished, and Engineer’s decision and estimates shall be final.”

- G. Delete Section 105.9.3 of the General Provisions titled “Inspection Overtime” in its entirety.
- H. Delete Section 107.2 of the General Provisions titled “Indemnification” in its entirety and replace with the following:

“THE CONTRACTOR AGREES TO INDEMNIFY, SAVE, PROTECT, DEFEND, AND HOLD HARMLESS THE OWNER, ITS AFFILIATES AND THEIR OFFICERS, DIRECTORS, AGENTS, INVITEES, AND EMPLOYEES (“INDEMNIFIED PARTIES”) FROM AND AGAINST ANY AND ALL LIABILITY, COST, DAMAGE, EXPENSES, FINES AND ALL REASONABLE LEGAL FEES AND COURT COSTS, CLAIMS, LOSSES, CAUSES OF ACTION, SUITS, AND LIABILITY OF ANY KIND, INCLUDING ALL EXPENSES OF LITIGATION AGAINST THE INDEMNIFIED PARTIES, WHETHER OR NOT CAUSED IN PART BY ANY ACT OR OMISSION OF A PERSON OR ENTITY INDEMNIFIED HEREUNDER, OR WHETHER LIABILITY IS IMPOSED UPON SUCH PERSON OR ENTITY, FOR ANY LOSS, INJURY, DAMAGE OR DEATH ARISING FROM OR OUT OF THE CONTRACTOR’S ACTS OR OMISSIONS, INCLUDING, BUT NOT LIMITED TO CONTRACTOR’S NEGLIGENT OR GROSSLY NEGLIGENT PERFORMANCE OF THE WORK; NEGLIGENT OR GROSSLY NEGLIGENT USE OR MISUSE OF OWNER’S PROPERTY; NEGLIGENT OR INTENTIONAL ACTIONS, ERRORS OR OMISSIONS AND THOSE OF ITS EMPLOYEES, OFFICERS, DIRECTORS, AGENTS OR SUBCONTRACTORS; VIOLATION OF ANY FEDERAL, STATE OR MUNICIPAL LAWS, REGULATIONS AND/OR ORDINANCES; CONTRACTOR’S OR ITS SUBCONTRACTOR’S USE OF PROPERTY, EQUIPMENT, VEHICLES, OR MATERIALS; DEFECTIVE WORKMANSHIP; NEGLIGENT OR GROSSLY NEGLIGENT USE OR MISUSE OF UTILITIES; OR SUBCONTRACTORS’, EMPLOYEES’, AGENTS’, OFFICERS’, OR DIRECTORS’ NEGLIGENCE OR INTENTIONAL TORTS. IT IS THE EXPRESS INTENT OF CONTRACTOR TO INDEMNIFY THE INDEMNIFIED PARTIES FROM THE CONSEQUENCES OF THEIR JOINT AND/OR CONCURRENT NEGLIGENCE AND/OR SOLE NEGLIGENCE. IN THE EVENT OF FAILURE BY THE

Belt Line Road Underground Electrical Phase I – Marsh Lane to Midway Road

CONTRACTOR TO FULLY PERFORM IN ACCORDANCE WITH THIS INDEMNIFICATION PARAGRAPH, EACH OF THE INDEMNIFIED PARTIES, AT ITS OPTION, AND WITHOUT RELIEVING CONTRACTOR OF ITS OBLIGATIONS HEREUNDER, MAY SO PERFORM, BUT ALL COSTS AND EXPENSES SO INCURRED BY ANY OF THE INDEMNIFIED PARTIES IN THAT EVENT SHALL BE REIMBURSED BY CONTRACTOR TO THE INDEMNIFIED PARTIES, OR ANY OF THEM, AND UNTIL REIMBURSED BY CONTRACTOR SHALL BEAR INTEREST, AT THE RATE OF INTEREST PROVIDED TO BE PAID ON JUDGMENT UNDER THE LAWS OF THE STATE OF TEXAS. THIS INDEMNIFICATION SHALL NOT BE LIMITED TO DAMAGES, COMPENSATION OR BENEFITS PAYABLE UNDER INSURANCE POLICIES, WORKERS' COMPENSATION ACTS, DISABILITY BENEFIT ACTS OR OTHER EMPLOYEE BENEFIT ACTS.

IN THE EVENT THIS CONTRACT RELATES TO A PROJECT OTHER THAN A SINGLE FAMILY HOUSE, TOWNHOUSE, DUPLEX, OR LAND DEVELOPMENT DIRECTLY RELATED THERETO OR A PUBLIC WORKS PROJECT OF A MUNICIPALITY THEN THE INDEMNITY PROVISIONS INCLUDED HEREIN SHALL BE LIMITED SUCH THAT SUBCONTRACTOR SHALL NOT BE REQUIRED TO INDEMNIFY, HOLD HARMLESS OR DEFEND CONTRACTOR OR ANY THIRD PARTIES AGAINST A CLAIM CAUSED BY THE NEGLIGENCE OR FAULT, THE BREACH OR VIOLATION OF A STATUTE, ORDINANCE, GOVERNMENTAL REGULATION, STANDARD, OR RULE, OR THE BREACH OF CONTRACT OF AN INDEMNIFIED PARTY, ITS AGENT OR EMPLOYEE, OR ANY THIRD PARTY UNDER THE CONTROL OR SUPERVISION OF THE INDEMNIFIED PARTY, OTHER THAN SUBCONTRACTOR OR ITS AGENT, EMPLOYEE, OR SUBCONTRACTOR OF ANY TIER EXCEPT THAT SUBCONTRACTOR SHALL INDEMNIFY, HOLD HARMLESS AND DEFEND THE INDEMNIFIED PARTY AGAINST ANY CLAIMS FOR THE BODILY INJURY OR DEATH OF AN EMPLOYEE OF SUBCONTRACTOR, ITS AGENTS, OR ITS SUBCONTRACTORS OF ANY TIER.

NOTWITHSTANDING ANYTHING HEREIN TO THE CONTRARY, THE INDEMNITY PROVISIONS INCLUDED HEREIN SHALL BE LIMITED SUCH THAT CONTRACTOR SHALL NOT BE REQUIRED TO

Belt Line Road Underground Electrical Phase I – Marsh Lane to Midway Road

INDEMNIFY, HOLD HARMLESS OR DEFEND OWNER OR ANY THIRD PARTIES AGAINST A CLAIM CAUSED BY THE NEGLIGENCE OR FAULT, THE BREACH OR VIOLATION OF A STATUTE, ORDINANCE, GOVERNMENTAL REGULATION, STANDARD, OR RULE, OR THE BREACH OF CONTRACT OF THE INDEMNIFIED PARTIES, ITS AGENT OR EMPLOYEE, OR ANY THIRD PARTY UNDER THE CONTROL OR SUPERVISION OF THE INDEMNIFIED PARTIES, OTHER THAN CONTRACTOR OR ITS AGENT, EMPLOYEE, OR SUBCONTRACTOR OF ANY TIER EXCEPT THAT CONTRACTOR SHALL INDEMNIFY, HOLD HARMLESS AND DEFEND THE INDEMNIFIED PARTIES AGAINST ANY CLAIMS FOR THE BODILY INJURY OR DEATH OF AN EMPLOYEE OF CONTRACTOR, ITS AGENTS, OR ITS SUBCONTRACTORS OF ANY TIER.”

- I. Add the following language after Section 103.3.1.4 of the General Provisions:

“103.3.1.5. Maintenance Bond. A good and sufficient bond in an amount not less than 10-percent of the approximate total of the Contract, as evidenced by the proposed tabulation, or conditioned on the full and proper maintenance and repair of the Work to be done and performed for a period of one year from the date of final acceptance of the Work and the Contractor will do all necessary backfilling that may arise on account of sunken conditions in ditches, or otherwise, and do and perform the necessary Work and repair any defective condition growing out of or arising from the improper laying or construction of same, or on account of any breaking of same caused by the Contractor in construction of same, or on account of any defect arising in any of the Work laid or constructed by the Contractor or on account of improper excavation or backfilling, it being understood that the purpose of this Section is to cover all defective conditions arising by reason of defective materials, Work, or labor performed by the Contractor.”

- J. Add the following language after Section 104.2.5. of the General Provisions:

“104.2.6. Change Orders. A Change Order is a written instrument and signed by the Owner, Contractor and Engineer stating their agreement upon all of the following:

- (1) the change in the Work;
- (2) the amount of the adjustment, if any, in the Contract Sum;
and
- (3) the extent of the adjustment, if any, in the Contract Time.

Belt Line Road Underground Electrical Phase I – Marsh Lane to Midway Road

In the event the Contractor proposes a Change Order, the Contractor shall provide sufficient detail for such Change Order to allow analysis and review by the Engineer.

Agreement on any Change Order shall constitute final agreement on the Work which is the subject of the Change Order, including, but not limited to, all direct and indirect costs associated with such change and any and all adjustments to the Contract Sum and the Contract Time. In the event a Change Order increases the Contract Sum, the Contractor shall include the Work covered by such Change Orders in Applications for Payment as if such Work were originally part of the Contract Documents.

The Contractor, upon receipt of written notification by the Owner or the Engineer of a proposed item or change in Work, shall prepare as soon as possible a Change Order on the form provided by the Owner. If the Change Order is returned to the Contractor for additional information or if the scope of the proposed change in the Work is modified by additions, deletions or other revisions, the Contractor shall revise the Change Order accordingly and resubmit the revised Change Order to the Owner and Engineer.”

- K. Delete the language in Section 105.2.1 of the General Provisions and replace it with the following language:

“105.2.1. WORKMANSHIP: If the OWNER notifies the CONTRACTOR in writing of defective work, the CONTRACTOR shall correct the deficiencies within five (5) calendar days of the Notice at no additional cost to the OWNER. If the defective work is not corrected within five (5) calendar days, or the CONTRACTOR is not making satisfactory progress (in the opinion of the OWNER) to correct the deficiencies, the OWNER may withhold future payments for All Work until the defective work has been corrected to the satisfaction of the OWNER.”

- L. Add the following language after Section 105.10 of the General Provisions:

“105.10.2. GUARANTEE AFTER COMPLETION: Unless otherwise specified in the technical section of these specifications, the CONTRACTOR shall, after test and acceptance, and for a period of one year from date of final written acceptance by the OWNER or within such longer or shorter period of time as may be prescribed by law or by the terms of any other applicable special warranty on designated equipment or portions of work as required by the Contract Documents, rebuild, repair, or replace any and all items which have proven defective due to unsatisfactory material and/or workmanship. Upon written notice from the OWNER, the

Belt Line Road Underground Electrical Phase I – Marsh Lane to Midway Road

CONTRACTOR shall immediately make any repairs that may be ordered, or such repairs will be made by the Owner at the expense of the CONTRACTOR or the CONTRACTOR'S Surety. In case of an emergency where delay would cause serious loss or damage, the Owner may undertake to have the defects repaired without previous notice. The expense of all repairs, including all emergency repairs, shall be borne by the CONTRACTOR or the CONTRACTOR'S Surety, at no cost to the Owner. This obligation shall survive termination of the Contract.

105.10.3. OFFSET PROGRESS PAYMENTS: OWNER may, at its option, offset any progress payment or final payment under the Contract Documents against any debt (including taxes) lawfully due to OWNER from Contractor, regardless of whether the amount due arises pursuant to the terms of the Contract Documents or otherwise and regardless of whether or not the debt due to OWNER has been reduced to judgment by a court.

105.10.4. FINAL ACCEPTANCE AND PAYMENT: This Project is subject to final inspection and final acceptance by the Owner. Whenever the Work provided for by the Contract shall have been completely performed on the part of the CONTRACTOR, including, but not limited to compliance with North Central Texas Council of Governments Standard Specifications for Public Works Construction, October 2004 Section 202.6.4.6., the CONTRACTOR shall notify the OWNER that the Work is ready for final inspection. The OWNER will then make such final inspection and if the work is satisfactory and in accordance with the specifications and contract documents, the OWNER shall issue a certificate of acceptance to the CONTRACTOR and submit a request to accept the Work performed by the CONTRACTOR and payment of a final estimate under the terms of which the OWNER will release 100% of the retainage, plus the unpaid portions of the final estimate as the OWNER deems advisable.

Whenever the improvements provided for by the Contract shall have been completely performed on the part of the Contractor, as evidenced in the certificate of acceptance, and all required submissions provided to the OWNER, a final estimate showing the value of the Work shall be prepared by the OWNER as soon as the necessary measurements and computations can be made. All prior estimates upon which payments have been made are subject to necessary corrections or revisions in the final payment. The amount of this final estimate, less any sums that have been previously paid, deducted or retained under the provisions of the contract, shall be paid the CONTRACTOR within 30 days after the

Belt Line Road Underground Electrical Phase I – Marsh Lane to Midway Road

final acceptance by the OWNER, provided the CONTRACTOR has furnished to the OWNER a consent of Surety and satisfactory evidence that all indebtedness connected with the Work and all sums of money due for any labor, materials, apparatus, fixtures, or machinery furnished for and used in the performance of the Work have been paid or otherwise satisfied, or that the person or persons to whom the same may respectively be due have consented to such final payment. This requirement is not intended and shall not be construed to recognize subcontractors for the purpose of privity of contract, and no third party benefit rights shall be obtained through these provisions for final payment. The acceptance by the CONTRACTOR of the final payment as aforesaid shall operate as and shall be a release to the OWNER from all claims or liabilities under the Contract, including all subcontractor claims, for anything done or furnished or relating to the Work under the Contract or for any act or neglect of said OWNER relating to or connected with the Contract.

All warranties and guarantees shall commence from the date of the certificate of acceptance. No interest shall be due the CONTRACTOR on any partial or final payment, or on the retainage.

105.10.5. RIGHT TO AUDIT CONTRACTOR'S RECORDS: By execution of the Contract, CONTRACTOR grants the OWNER the right to audit, at Owner's election, all of CONTRACTOR'S records and billings relating to the performance of the Work under the Contract. CONTRACTOR agrees to retain such records for a minimum of three (3) years following completion of the Work under this Contract. OWNER agrees that it will exercise the right to audit only at reasonable hours."

M. Add the following language after Section 107.5 of the General Provisions:

"107.5.1. COMPENSATION AND ACKNOWLEDGEMENT OF WORK: The CONTRACTOR shall receive and accept compensation, as herein provided, as full payment for furnishing all labor, tools, material, equipment and incidentals; for performing all Work contemplated and embraced under the Contract; for all loss or damage arising out of the nature of the Work, or from the action of the elements; for any unforeseen defects or obstruction which may arise or be encountered during the prosecution of the Work and before its final acceptance by the OWNER; for all risks of whatever description connected with the prosecution of the Work; for all expense incurred by or in consequence of suspension or discontinuance of such prosecution of the Work as herein specified; for any infringement of patents, trademarks or

Belt Line Road Underground Electrical Phase I – Marsh Lane to Midway Road

copyrights; and for completing the Work in an acceptable manner according to the Plans and Specifications.”

- N. Add the following language after Section 107.11 of the General Provisions:

“107.11.1. COOPERATION OF THE CONTRACTOR: The CONTRACTOR shall give to the work the consistent attention necessary to facilitate the progress thereof, and the CONTRACTOR shall cooperate with the OWNER, and with other CONTRACTORS in every way possible.

The OWNER and the OWNER’S representatives shall at all times have free access to the Work whenever it is in preparation or progress and the contractor shall provide safe, convenient and proper facilities for such access and inspection.”

- O. Delete Section 107.4 of the General Provisions and replace it with the following:

“107.4. VENUE AND CHOICE OF LAW

The Owner, the Contractor, and the Contractor’s sureties agree that this Contract shall be performed in Dallas, Dallas County, Texas, and if legal action is necessary in connection therewith, exclusive venue shall lie in Dallas County, Texas. The terms and provisions of the Contract Documents shall be construed in accordance with the laws and court decisions of the State of Texas.”

- P. Delete the following language (which is the first paragraph) from Section 109.5.1. of the General Provisions:

“Between the 25th day and the last day of each month, the Owner shall make an approximate estimate of the value of the work done during the month under the specifications. Whenever the said estimate or estimates of work done since the last previous estimate exceeds \$100 in amount, a percentage of such estimate sum shall be paid the Contractor on or before the 15th day of the month next following. The monthly estimate may include acceptable nonperishable materials delivered to the work; such payment shall be allowed on the same percentage basis of the net invoice value as provided hereinafter. The percent retained by the owner shall normally be up to 10 percent at completion, unless otherwise stated. At the midpoint, or at any subsequent time, if the owner determines that the progress of the Contract is satisfactory in all respects, it may at its discretion cease to retain additional funds until the completion of the project, or until progress ceases to be satisfactory. The owner shall make the sole determination in this matter.”

Belt Line Road Underground Electrical Phase I – Marsh Lane to Midway Road

Q. Add the following language after Section 109.5.1. of the General Provisions:

“109.5.1.1. Applications for Payment. Applications for progress payment (“Application for Payment”) will be submitted no more often than monthly and shall be submitted on the dates set forth in the Agreement. Each Application for Payment shall be (1) sworn to and notarized, (2) supported by such data substantiating the Contractor’s right to payment as the Owner or Engineer may require, such as copies of requisitions from Subcontractors and material suppliers, and reflecting retainage if provided for in the Contract Documents, and (3) submitted by the Contractor for review to the Engineer in form and substance as mandated by the Owner. The Contractor’s Application for Payment shall be segregated and detailed in a manner satisfactory to the Owner.

In each Application for Payment, the Contractor shall certify that such Application for Payment represents a just estimate of portion of the Work that is complete as of the last day covered by the Application for Payment and shall also certify by sworn affidavit as follows:

‘There are no known mechanics’ or materialmen’s liens outstanding at the date of this Application, all due and payable bills with respect to the Work have been paid to date or shall be paid from the proceeds of this Application for Payment, there is no known basis for filing of any mechanics’ or materialmen’s liens on the Work, and waivers from all subcontractors and materialmen have been or, at the time of payment, will be obtained in such form as to constitute an effective waiver of lien under the applicable laws of the State of Texas.’

109.5.1.2. Lien Waivers. Concurrent with each Application for Payment, the Contractor shall execute and furnish a waiver and release of its lien rights current through the effective date of such Application for Payment conditioned upon receipt of the payment that is the subject of the application. Beginning with the second Application for Payment, the Contractor shall also deliver with each such Application as a condition precedent to payment thereof, waivers of lien from each of the Subcontractors, Sub-subcontractors, and suppliers current through the effective date of the previous Application of Payment. The Contractor shall also execute and obtain any other reasonable forms as the Owner may require in order to assure an effective waiver and release of mechanics’ and materialmen’s liens in compliance with the laws of the State of Texas. The Contractor shall, if any Subcontractor, Sub-subcontractor or supplier refuses to furnish a release in full,

Belt Line Road Underground Electrical Phase I – Marsh Lane to Midway Road

furnish a bond satisfactory to the Owner to indemnify against any lien.”

- R. Delete Section 109.5.2 of the General Provisions and replace with the following:

“Ten-percent (10%) retainage shall be withheld until 40 days after Final Completion.”

109. CONTRACTOR REPRESENTATIONS: By entering into the Contract, the Contractor makes the following representations to the Town of Addison:

- A. Contractor has examined and carefully studied the Bidding Documents and the related data identified in the Bidding Documents.
- B. The Contractor has visited the Project site where the goods are to be installed or services will be provided and become familiar with and is satisfied as to the observable local conditions that may affect cost, progress, or the furnishing of goods and services, if required to do so by the Bidding Documents, or if, in the Contractor’s judgment, any local condition may affect cost, progress, or the furnishing of goods and services.
- C. The Contractor is familiar with and is satisfied as to all Laws and Regulations in effect as of the date of the bid that may affect cost, progress, and the furnishing of goods and services.
- D. The Contractor has carefully studied, considered, and correlated the information known to the Contractor; information commonly known to sellers of similar goods doing business in the locality of the Project site where the goods will be installed or where services will be provided; information and observations obtained from the Contractor’s visits, if any, to the Project site where the goods will be installed or services will be provided; and any reports and drawings identified in the Bidding Documents regarding the Project site where the goods will be installed or where services will be provided, with respect to the effect of such information, observations, and documents on the cost, progress, and performance of the Contractor’s obligations under the Bidding Documents.
- E. The Contractor has given the Engineer written notice of all conflicts, errors, ambiguities, and discrepancies that the Contractor has discovered in the Bidding Documents, and the written resolution (if any) thereof by the Engineer is acceptable to the Contractor.
- F. The Bidding Documents are generally sufficient to indicate and convey understanding of all terms and conditions for furnishing the goods and services for which the bid is submitted
- G. The Contractor acknowledges that estimated quantities are not guaranteed, and are solely for the purpose of comparison of bids, and final payment for all unit price bid items will be based on actual quantities, determined as provided in the

Belt Line Road Underground Electrical Phase I – Marsh Lane to Midway Road

Contract Documents. The Contractor also acknowledges that each unit price includes an amount considered by the Contractor to be adequate to cover the Contractor's overhead and profit for each separately identified item.

- 110. PREVAILING WAGE RATES:** Wage rates paid on this Project shall not be less than specified in the schedule of general prevailing rates of per diem wages as set forth below in the Davis Bacon Act General Decision No. TX130035:

General Decision Number: TX130035 01/04/2013 TX35

Superseded General Decision Number: TX20120035

State: Texas

Construction Type: Highway

Counties: Archer, Callahan, Clay, Collin, Dallas, Delta, Denton, Ellis, Grayson, Hunt, Johnson, Jones, Kaufman, Parker, Rockwall, Tarrant and Wise Counties in Texas.

HIGHWAY CONSTRUCTION PROJECTS (excluding tunnels, building structures in rest area projects & railroad construction; bascule, suspension & spandrel arch bridges designed for commercial navigation, bridges involving marine construction; and other major bridges).

Modification Number Publication Date 0 01/04/2013
* SUTX2011-007 08/03/2011

	Rates	Fringes
CONCRETE FINISHER (Paving and Structures)	\$14.12	
ELECTRICIAN	\$19.80	
FORM BUILDER/FORM SETTER		
Paving & Curb	\$13.16	
Structures	\$13.84	
LABORER		
Asphalt Raker	\$12.69	
Flagger	\$10.06	
Laborer, Common	\$10.72	
Laborer, Utility	\$12.32	
Pipelayer	\$13.24	
Work Zone Barricade Servicer	\$11.68	
POWER EQUIPMENT OPERATOR:		
Asphalt Distributor	\$15.32	
Asphalt Paving Machine	\$13.99	
Broom or Sweeper Concrete Pavement	\$11.74	
Finishing Machine	\$16.05	

Belt Line Road Underground Electrical Phase I – Marsh Lane to Midway Road

Concrete Saw	\$14.48
Crane Operator, Lattice Boom 80 Tons or Less	\$17.27
Crane Operator, Lattice Boom over 80 Tons	\$20.52
Crane, Hydraulic 80 Tons or Less	\$18.12
Crawler Tractor	\$14.07
Excavator, 50,000 pounds or Less	\$17.19
Excavator, over 50,000 pounds	\$16.99
Foundation Drill , Truck Mounted	\$21.07
Foundation Drill, Crawler Mounted	\$17.99
Front End Loader 3 CY or Less	\$13.69
Front End Loader, over 3 CY	\$14.72
Loader/Backhoe	\$15.18
Mechanic	\$17.68
Milling Machine	\$14.32
Motor Grader, Fine Grade	\$17.19
Motor Grader, Rough	\$16.02
Pavement Marking Machine	\$13.63
Reclaimer/Pulverizer	\$11.01
Roller, Asphalt	\$13.08
Roller, Other	\$11.51
Scraper	\$12.96
Small Slipform Machine	\$15.96
Spreader Box	\$14.73
Servicer	\$14.58
Steel Worker (Reinforcing)	\$16.18
TRUCK DRIVER	
Lowboy-Float	\$16.24
Off Road Hauler	\$12.25
Single Axle	\$12.31
Single or Tandem Axle Dump Trunk	\$12.62
Tandem Axle Tractor with Semi Trailer	\$12.86
Transit-Mix	\$14.14
WELDER	\$14.84

WELDERS - Receive rate prescribed for craft performing operation to which welding is incidental.

Unlisted classifications needed for work not included within the scope of the classifications listed may be added after award only as provided in the labor standards contract clauses (29CFR 5.5 (a) (1) (ii)).

The body of each wage determination lists the classification and wage rates that have been found to be prevailing for the cited type(s) of construction in the area covered by the wage

Belt Line Road Underground Electrical Phase I – Marsh Lane to Midway Road

determination. The classifications are listed in alphabetical order of “identifiers” that indicate whether the particular rate is union or non-union.

Union Identifiers

An identifier enclosed in dotted lines beginning with characters other than “SU” denotes that the union classification and rate have found to be prevailing for that classification. Example: PLUM0198-005 07/01/2011. The first four letters , PLUM, indicate the international union and the four-digit number, 0198, that follows indicates the local union number or district council number where applicable , i.e., Plumbers Local 0198. The next number, 005 in the example, is an internal number used in processing the wage determination. The date, 07/01/2011, following these characters is the effective date of the most current negotiated rate/collective bargaining agreement which would be July 1, 2011 in the above example.

Union prevailing wage rates will be updated to reflect any changes in the collective bargaining agreements governing the rates.

0000/9999: weighted union wage rates will be published annually each January.

Non-Union Identifiers

Classifications listed under an “SU” identifier were derived from survey data by computing average rates and are not union rates; however, the data used in computing these rates may include both union and non-union data. Example: SULA2004-007 5/13/2010. SU indicates the rates are not union majority rates, LA indicates the State of Louisiana; 2004 is the year of the survey; and 007 is an internal number used in producing the wage determination. A 1993 or later date, 5/13/2010, indicates the classifications and rates under that identifier were issued as a General Wage Determination on that date.

Survey wage rates will remain in effect and will not change until a new survey is conducted.

WAGE DETERMINATION APPEALS PROCESS

1.) Has there been an initial decision in the matter? This can be:

- * an existing published wage determination
- * a survey underlying a wage determination
- * a Wage and Hour Division letter setting forth a position on a wage determination matter
- * a conformance (additional classification and rate) ruling

On survey related matters, initial contact, including requests for summaries of surveys, should be with the Wage and Hour Regional Office for the area in which the survey was conducted because those Regional Offices have responsibility for the Davis-Bacon survey program. If the response from this initial contact is not satisfactory, then the process described in 2.) and 3.) should be followed.

Belt Line Road Underground Electrical Phase I – Marsh Lane to Midway Road

With regard to any other matter not yet ripe for the formal process described here, initial contact should be with the Branch of Construction Wage Determinations. Write to:

Branch of Construction Wage Determinations
Wage and Hour Division
U.S. Department of Labor
200 Constitution Avenue, N.W.
Washington, DC 20210

2.) If the answer to the question in 1.) is yes, then an interested party (those affected by the action) can request review and reconsideration from the Wage and Hour Administrator (See 29 CFR Part 1.8 and 29 CFR Part 7). Write to:

Wage and Hour Administrator
U.S. Department of Labor
200 Constitution Avenue, N.W.
Washington, DC 20210

The request should be accompanied by a full statement of the interested party's position and by any information (wage payment data, project description, area practice material, etc.) that the requestor considers relevant to the issue.

3.) If the decision of the Administrator is not favorable, an interested party may appeal directly to the Administrative Review Board (formerly the Wage Appeals Board). Write to:

Administrative Review Board
U.S. Department of Labor
200 Constitution Avenue, N.W.
Washington, DC 20210

4.) All decisions by the Administrative Review Board are final.

END OF GENERAL DECISION

111. **BID ITEMS/REFERENCE SPECIFICATIONS:** The requirements of NCTCOG standard specifications for Public Works construction 4th Edition dated 2004, and TxDOT standard specifications for construction and maintenance of highways, streets and bridges, dated 2004, shall apply as described.

SPECIAL PROVISIONS

Note: The series of numbers shown after the description are for either the Texas Department of Transportation (TxDOT) Standard Specifications for Construction and Maintenance of Highways, Streets, and Bridges (2004), the North Central Texas Council of Governments (NCTCOG) Standard Specifications for Public Works Construction, Fourth Edition (October 2004), or technical specifications number provided with this document.

Belt Line Road Underground Electrical Phase I – Marsh Lane to Midway Road

SITE PREPARATION AND MISCELLANEOUS

BID ITEM NO. 1.01 – Mobilization (no more than 5% of total bid)

The provisions of NCTCOG Item 203, “Site Preparation”, shall apply except as modified or clarified below:

- A. Partial payments of the lump sum bid for mobilization shall be per the provisions of TxDOT Item 500.
- B. Measurement for this bid item shall be for lump sum.
- C. Payment for this bid item shall be paid for at the unit price bid for “Mobilization”.

BID ITEM NO. 1.02 – Traffic Control

The following provisions shall apply:

- A. Contractor shall submit proposed traffic control plan (TCP) changes to the Engineer and Town for approval. Changes must conform to guidelines established in the TMUTCD.
- B. This item includes all labor, equipment, materials and incidentals required to provide traffic control as necessary. Materials include but are not limited to signage including full time changeable message signs, traffic control devices, barricades, low profile concrete barrier, temporary striping, and any other items called for in the plans or necessary for the safe and efficient operation of traffic.
- C. Contractor shall provide access to existing driveways at all times, except when concrete is curing. Gravel shall be placed at driveways once existing pavement has been removed for utility crossings. Gravel material is incidental to this bid item.
- D. Measurement for this bid item shall be per lump sum.
- E. Payment for this bid item shall be paid for at the unit price bid for “Traffic Control”.

BID ITEM NO. 1.03 – SW3P including maintenance, inlet protections and erosion control

The provisions of NCTCOG Item 201, “Temporary Erosion, Sedimentation, and Water Pollution Prevention and Control”, shall apply except as modified or clarified below:

- A. Refer to NCTCOG Item 201.3, “Preconstruction Submittals”, and Special Provisions, Number 15, “Preparations of Storm Water Pollution Prevention Plan,” for additional specification on submitting the Storm Water Pollution Prevention Plan prior to the beginning of construction.
- B. Refer to NCTCOG Item 201.4, “Construction Requirements”, for additional specification on erosion control during construction.
- C. Refer to NCTCOG Item 201.5, “Silt Fence”, for additional specification regarding inlet protection.

Belt Line Road Underground Electrical Phase I – Marsh Lane to Midway Road

- D. Refer to NCTCOG Item 201.14, “Inlet Protection”, for additional specification regarding inlet protection.
- E. Contractor shall refer to the Stormwater Pollution Prevention Plan (SWPPP) for requirements of all temporary and permanent erosion control measures. Preparation of the SWPPP shall be subsidiary to these bid items.
- F. Refer to Erosion Control Details and Notes located in the Erosion Control Plans and Details for additional information and locations of silt fences.
- G. Measurement for this bid item shall be per linear foot (silt fence), per each (inlet protection and construction entrance), and per lump sum (SW3P including maintenance and erosion control).
- H. Payment for this bid item shall be paid for at the unit price bid for “SW3P Including Maintenance, Inlet Protection and Erosion Control”.

BID ITEM NO. 1.04 – Remove and replace median

This item shall include removal and replacement of median areas to their current existing condition after utility/paving operations have been completed.

- A. This item includes all labor, equipment, materials and incidentals required to remove existing concrete in accordance with plans and specifications. Refer to the Special Provision for “Curb Ramp” for additional curb removal information.
- B. Median areas which include plantings, irrigation, brick pavers, shall be completely restored. Refer to Specification Section 32-9300, “Landscape Planting” for additional requirements.
- C. This item when called for in the plans shall include saw cutting the concrete and disposal of the material at an approved location outside of the project limits. This surplus material shall become property of the Contractor.
- D. This item shall also include removal of asphalt pavement, or asphalt overlay within the limits called for in the plans.
- E. Concrete and /or Asphalt shall be properly disposed of at an off-site location by the Contractor.
- F. Existing roadway will be demolished and removed in phases. Refer to Traffic Control Plan for Construction Sequence.
- G. Measurement for this bid item shall be per square yard.
- H. Payment for this bid item shall be paid for at the unit price bid for “Remove and Replace median.”

BID ITEM NO. 1.05 – Remove Existing Concrete Pavement, 1.06 – Remove Existing Concrete Sidewalk

Belt Line Road Underground Electrical Phase I – Marsh Lane to Midway Road

The provisions of TxDOT Item 104, “Removing Concrete”, shall apply except as modified or clarified below:

- A. This item includes all labor, equipment, materials and incidentals required to eliminate existing concrete in accordance with plans and specifications. Refer to the Special Provision for “Curb Ramp” for additional curb removal information.
- B. This item when called for in the plans shall include saw cutting the concrete and disposal of the material at an approved location outside of the project limits. This surplus material shall become property of the Contractor.
- C. Concrete and /or Asphalt shall be properly disposed of at an off-site location by the Contractor.
- D. Existing roadway will be demolished and removed in phases. Refer to Traffic Control Plan for Construction Sequence.
- E. Measurement for this bid item shall be per square yard for pavement and per square foot for sidewalk.
- F. Payment for this bid item shall be paid for at the unit price bid for “Remove Existing Concrete Pavement”, “Remove Existing Concrete Sidewalk”.

BID ITEM NO. 1.07 – Project Signs

The provisions of NCTCOG Item 107.20, “Project Signs”, shall apply except as modified or clarified below:

- A. The Contractor shall be responsible for furnishing the project signs per the specifications shown on the Project Sign Detail Sheet (see Section PS of this Contract Documents and Specifications book).
- B. Measurement for this bid item shall be for each.
- C. Payment for this bid item shall be paid for at the unit price bid for “Project Signs”.

BID ITEM NO. 1.08 – Remove and Relocate Light Poles

This item provides for removing, salvaging and reinstalling existing light poles as required and shall include all labor, equipment, materials and incidentals required to complete the relocation in accordance with plans and specifications

- A. Measurement for this bid item shall be for each.
- B. Payment for this bid item shall be paid for at the unit price bid for “Remove and Relocate Light Poles”.

PAVING AND SIDEWALKS

BID ITEM NO. 2.01 – 3/4" Novachip (95 lb/sy-in) – NOT USED

The provisions of TxDOT item 350, “micro surfacing” and specification section 3001 shall apply.

BID ITEM NO. 2.02 – Asphalt Membrane (0.25 gal/sy) – NOT USED

The provisions of TxDOT Item 316, “Surface Treatments”, shall apply except as modified or clarified below:

- A. Refer to Belt Line Road Paving plans and Construction Details for location of Membrane placement.
- B. This item includes all labor, equipment, materials and incidentals required to provide and install tack coat and prime coat in accordance with plans and specifications.
- C. Measurement for this bid item shall be per gallon at point of delivery, based on area covered.
- D. Payment for this bid item shall be paid for at the unit price bid for “Asphalt Membrane (0.25 gal/sy)”.

BID ITEM NO. 2.03 – Milling – NOT USED

The provisions of TxDOT item 354, “Planing and Texturing Pavement” shall apply.

BID ITEM NO. 2.04 – Full Depth Repair

The provisions of NCTCOG Item 303 "Portland Cement Concrete Pavement" shall apply except when modified by condition B below.

- A. This item includes all labor, equipment, materials and incidentals required to provide concrete pavement for trenches and areas to be repaired in accordance with plans and specifications.
- B. Cost of pavement removal is included in this bid item.
- C. If the timeframe for opening to traffic is less than 72 hours after concrete placement, provide concrete meeting TxDOT Item 360, class HES concrete.
- D. Measurement will be by the square yard, regardless of pavement thickness or use of class HES concrete.
- E. Payment for this bid item shall be paid for at the unit price bid for "Full Depth Repair”.

BID ITEM NO. 2.05 – Median/Island Adjustment

Belt Line Road Underground Electrical Phase I – Marsh Lane to Midway Road

The provisions of NCTCOG Item 303 "Portland Cement Concrete Pavement" shall apply.

BID ITEM NO. 2.06 – Concrete Curb & Gutter

The provisions of NCTCOG Item 529, "Concrete Curb, Gutter, and Combined Curb and Gutter", shall apply except as modified or clarified below:

- A. This item includes all labor, equipment, materials and incidentals required to provide monolithic concrete curb and gutter in accordance with plans and specifications.
- B. Refer to Paving Plan and Construction details for location, general notes and details.
- C. When specified, concrete curb shall be poured monolithically with pavement.
- D. Curb height is six inches (6") tall.
- E. Concrete shall be of the same class and compressive strength as the pavement.
- F. Measurement for this bid item shall be per linear foot.
- G. Payment for this bid item shall be paid for at the unit price bid for "Concrete Curb and Gutter".

BID ITEM NO. 2.07 – Concrete Edge

The provisions of NCTCOG Item 529, "Concrete Curb, Gutter, and Combined Curb and Gutter", shall apply except as modified or clarified below:

- A. This item includes all labor, equipment, materials and incidentals required to provide concrete edge in accordance with plans and specifications.
- B. Refer to Paving Plan and Construction details for location, general notes and details.
- C. When specified, concrete edge shall be poured monolithically with pavement.
- D. Concrete shall be of the same class and compressive strength as the pavement.
- E. Measurement for this bid item shall be per linear foot.
- F. Payment for this bid item shall be paid for at the unit price bid for "Concrete Edge".

BID ITEM NO. 2.08 – Concrete Sidewalk

The provisions of NCTCOG Item 305.2, "Sidewalks", shall apply except as modified or clarified below:

- A. This item includes all labor, equipment, materials and incidentals required to provide a finished concrete pavement section including any required saw joints and expansion joints in accordance with the specifications. Any concrete sidewalk which tests below the required strength or is out of alignment or is of insufficient thickness, is subject to removal and replacement at the Engineer's sole discretion at the Contractor's expense.

Belt Line Road Underground Electrical Phase I – Marsh Lane to Midway Road

- B. Sidewalks five feet wide or smaller shall have a thickness of four inches (4"). Sidewalks greater than five feet wide shall have a thickness of five inches (5").
- C. Concrete shall be Class 'C' concrete designed to meet an average compressive strength of 3,600 psi at 28 days.
- D. Measurement for this bid item shall be per square foot.
- E. Payment for this bid item shall be paid for at the unit price bid for "Concrete Sidewalk".

BID ITEM NO. 2.09 – Curb Ramp – Directional, Non Directional and Flared

The provisions of TxDOT Item 531, "Sidewalks", shall apply except as modified or clarified below:

- A. This item includes all labor, equipment, materials and incidentals required to provide curb ramp in accordance with plans and specifications.
- B. Refer to TxDOT Standard Sheet "Pedestrian Facilities" (PED-12) and Pavement Details for general notes and details.
- C. Detectable warning surface shall be considered part of the curb ramp and shall consist of the following:
 - 1) Detectable Warning Plates shall be "Armorcast wet set panel" or Town approved equal.
- D. Concrete shall be Class 'C' concrete design to meet a minimum average compressive strength of 3,600 psi at 28 days.
- E. Refer to Paving Plans for curb ramp location, type, and general notes.
- F. Removal and replacement of existing concrete curb adjacent to proposed curb ramp is subsidiary to this bid item. Curb removal in these locations is not included in the quantity for bid items regarding removal of existing concrete.
- G. Measurement for this bid item shall be per each.
- H. Payment for this bid item shall be paid for at the unit price bid for "Curb Ramp" of the type specified in the plans.

BID ITEM NO. 2.10 – Island Curb Ramp

The provisions of TxDOT Item 531, "Sidewalks", shall apply except as modified or clarified below:

- A. This item includes all labor, equipment, materials and incidentals required to provide curb ramp in accordance with plans and specifications.
- B. Refer to TxDOT Standard Sheet "Pedestrian Facilities" (PED-12) and Pavement Details for general notes and details.

Belt Line Road Underground Electrical Phase I – Marsh Lane to Midway Road

- C. Detectable warning surface shall be considered part of the island curb ramp and shall consist of the following:
 - 1) Detectable Warning Plates shall be “Armorcast wet set panel” or Town approved equal.
- D. Concrete shall be Class ‘C’ concrete design to meet a minimum average compressive strength of 3,600 psi at 28 days.
- E. Refer to Paving Plans for curb ramp location, type, and general notes.
- F. Removal and replacement of existing concrete curb adjacent to proposed curb ramp is subsidiary to this bid item. Curb removal in this location is not included in the quantity for bid items regarding removal of existing concrete
- G. Measurement for this bid item shall be per each.
- H. Payment for this bid item shall be paid for at the unit price bid for “Island Curb Ramp” of the type specified.

BID ITEM NO. 2.11 – Variable height sidewalk wall

The provisions of TxDOT Item 520, “Concrete Structures”, shall apply except as modified or clarified below:

- A. This item includes all labor, equipment, materials and incidentals required to provide Variable height sidewalk wall in accordance with plans and specifications.
- B. Concrete shall be Class ‘C’ concrete design to meet a minimum average compressive strength of 3,600 psi at 28 days.
- C. Refer to Paving Plans for location, type, and general notes.
- D. Measurement for this bid item shall be by the linear foot.
- E. Payment for this bid item shall be paid for at the unit price bid for “Variable height sidewalk wall” of the type specified in the plans.

BID ITEM NO. 2.12 – Variable height unit paver wall

- A. This item includes all labor, equipment, materials and incidentals required to provide "Variable height unit paver wall" in accordance with plans and specifications.
- B. Pavers shall either be salvaged and reused for existing locations, or be approved by the engineer for new locations.
- C. Refer to Paving Plans for location, type, and general notes.
- D. Measurement for this bid item shall be by the linear foot.

Belt Line Road Underground Electrical Phase I – Marsh Lane to Midway Road

- E. Payment for this bid item shall be paid for at the unit price bid for “Variable height unit paver wall” of the type specified in the plans.

BID ITEM NO. 2.13 – Superpave Mixtures SP-D SAC-B PG70-22 (Rich Bottom Layer Asphalt Edge Repair) – NOT USED

The provisions of TxDOT Item 344, “Performance Designed Mixtures”, shall apply except as modified or clarified below:

- A. Refer to Belt Line Road Paving plans and Construction Details for location of edge repair.
- B. This item includes all labor, equipment, materials and incidentals required to provide and install edge repair in accordance with plans and specifications.
- C. Measurement for this bid item shall be per Ton.
- D. Payment for this bid item shall be paid for at the unit price bid for " Superpave mixtures SP-D SAC-B PG70-22 (Rich Bottom Layer Asphalt Edge Repair).

PAVEMENT MARKINGS AND SIGNS

BID ITEM NO. 3.01 – White Thermo Turn Arrow (125 mil. Thickness) – NOT USED

The provisions of TxDOT Item 668, “Prefabricated pavement markings”, shall apply.

BID ITEM NO. 3.02 – White Thermo Lettering "ONLY" (125 mil. Thickness) – NOT USED

The provisions of TxDOT Item 668, “Prefabricated pavement markings”, shall apply.

BID ITEM NO. 3.03 – 4" Type I White Skip Thermo (90 mil. Thickness) – NOT USED

The provisions of TxDOT Item 668, “Prefabricated pavement markings”, shall apply.

BID ITEM NO. 3.04 – 4" Type I White Dot Thermo (90 mil. Thickness) – NOT USED

The provisions of TxDOT Item 668, “Prefabricated pavement markings”, shall apply.

BID ITEM NO. 3.05 – 4" Type I Yellow Solid Thermo (90 mil. Thickness) – NOT USED

The provisions of TxDOT Item 668, “Prefabricated pavement markings”, shall apply.

BID ITEM NO. 3.06 – 8" Type I White Solid Thermo (90 mil. Thickness) – NOT USED

Belt Line Road Underground Electrical Phase I – Marsh Lane to Midway Road

The provisions of TxDOT Item 668, “Prefabricated pavement markings”, shall apply.

BID ITEM NO. 3.07 – 24" Type I White Thermo Stop Bar (125 mil. Thickness) – NOT USED

The provisions of TxDOT Item 668, “Prefabricated pavement markings”, shall apply.

BID ITEM NO. 3.08 – 12" Type I White Thermo Transverse Crosswalk (125 mil. Thickness) – NOT USED

The provisions of TxDOT Item 668, “Prefabricated pavement markings”, shall apply.

BID ITEM NO. 3.09 – White Thermo Yield Line (125 mil. Thickness) – NOT USED

The provisions of TxDOT Item 668, “Prefabricated pavement markings”, shall apply.

BID ITEM NO. 3.10 – Pavement Sealer (Arrow) – NOT USED

The provisions of TxDOT Item 678, “Pavement Surface Preparation for Markings”, shall apply except as modified or clarified below:

- A. Refer to Signage and Striping Plans and Construction Details for location of reflectorized pavement markings, details, and general notes.
- B. Measurement for this bid item shall be per each (words or arrows) or linear foot (striping).
- C. Payment for this bid item shall be paid for at the unit price bid for “Pavement Sealer” of the type specified.

BID ITEM NO. 3.11– Pavement Sealer (Word) – NOT USED

The provisions of TxDOT Item 678, “Pavement Surface Preparation for Markings”, shall apply except as modified or clarified below:

- A. Refer to Signage and Striping Plans and Construction Details for location of reflectorized pavement markings, details, and general notes.
- B. Measurement for this bid item shall be per each (words or arrows) or linear foot (striping).
- C. Payment for this bid item shall be paid for at the unit price bid for “Pavement Sealer” of the type specified.

BID ITEM NO. 3.12 – Pavement Sealer 4"– NOT USED

The provisions of TxDOT Item 678, “Pavement Surface Preparation for Markings”, shall apply except as modified or clarified below:

Belt Line Road Underground Electrical Phase I – Marsh Lane to Midway Road

- A. Refer to Signage and Striping Plans and Construction Details for location of reflectorized pavement markings, details, and general notes.
- B. Measurement for this bid item shall be per each (words or arrows) or linear foot (striping).
- C. Payment for this bid item shall be paid for at the unit price bid for “Pavement Sealer” of the type specified.

BID ITEM NO. 3.13 – Pavement Sealer 8"– NOT USED

The provisions of TxDOT Item 678, “Pavement Surface Preparation for Markings”, shall apply except as modified or clarified below:

- A. Refer to Signage and Striping Plans and Construction Details for location of reflectorized pavement markings, details, and general notes.
- B. Measurement for this bid item shall be per each (words or arrows) or linear foot (striping).
- C. Payment for this bid item shall be paid for at the unit price bid for “Pavement Sealer” of the type specified.

BID ITEM NO. 3.14 – Pavement Sealer 12"– NOT USED

The provisions of TxDOT Item 678, “Pavement Surface Preparation for Markings”, shall apply except as modified or clarified below:

- A. Refer to Signage and Striping Plans and Construction Details for location of reflectorized pavement markings, details, and general notes.
- B. Measurement for this bid item shall be per each (words or arrows) or linear foot (striping).
- C. Payment for this bid item shall be paid for at the unit price bid for “Pavement Sealer ” of the type specified.

BID ITEM NO. 3.15 – Pavement Sealer 24"– NOT USED

The provisions of TxDOT Item 678, “Pavement Surface Preparation for Markings”, shall apply except as modified or clarified below:

- A. Refer to Signage and Striping Plans and Construction Details for location of reflectorized pavement markings, details, and general notes.
- B. Measurement for this bid item shall be per each (words or arrows) or linear foot (striping).
- C. Payment for this bid item shall be paid for at the unit price bid for “Pavement Sealer” of the type specified.

Belt Line Road Underground Electrical Phase I – Marsh Lane to Midway Road

BID ITEM NO. 3.16 – Pavement Sealer Yield Line– NOT USED

The provisions of TxDOT Item 678, “Pavement Surface Preparation for Markings”, shall apply except as modified or clarified below:

- A. Refer to Signage and Striping Plans and Construction Details for location of reflectorized pavement markings, details, and general notes.
- B. Measurement for this bid item shall be per each (words or arrows) or linear foot (striping).
- C. Payment for this bid item shall be paid for at the unit price bid for “Pavement Sealer” of the type specified.

BID ITEM NO. 3.17 – White R.P.M. Type II-C-R– NOT USED

The provisions of TxDOT Item 672, “Raised Pavement Markings”, shall apply.

BID ITEM NO. 3.18 – Yellow R.P.M Type II-A-A– NOT USED

The provisions of TxDOT Item 672, “Raised Pavement Markings”, shall apply.

BID ITEM NO. 3.19 – 4"Round Non-Reflective Yellow Marker– NOT USED

The provisions of TxDOT Item 672, “Raised Pavement Markings”, shall apply.

BID ITEM NO. 3.20 – Small Aluminum Road Sign

- A. This item includes all labor, equipment, materials and incidentals required to provide "Small Aluminum Road Signs" in accordance with plans and specifications.
- B. Measurement for this bid item shall be per each.
- C. Payment for this bid item shall be paid for at the unit price bid for each sign, complete in place.

BID ITEM NO. 3.21 – Relocate existing signs

- A. This item includes all labor, equipment, materials and incidentals required to provide "Relocate existing signs" in accordance with plans and specifications.
- B. Measurement for this bid item shall be lump sum.
- C. Payment for this bid item shall be paid for at the unit price bid for all necessary sign relocations, complete in place.

BID ITEM NO. 3.22 – White R.P.M. Type I-C– NOT USED

Belt Line Road Underground Electrical Phase I – Marsh Lane to Midway Road

The provisions of TxDOT Item 672, “Raised Pavement Markings”, shall apply.

DRAINAGE IMPROVEMENTS

BID ITEM NO. 4.01 – RC Pipe (CL III) (18 in)

The provisions of TxDOT Item 464, “Reinforced Concrete Pipe”, shall apply except as modified or clarified below:

- A. Refer to TxDOT Item 464 for materials, installation, jointing, and fittings.
- B. Reinforced concrete pipe shall be Class III unless noted otherwise in the plans.
- C. All proposed storm sewer connections shall be pre-fabricated. Field connections can be used for connections to existing lines only.
- D. Pipe collars shall be installed at all pipe size and grade changes.
- E. Refer to storm drain details for general notes, backfill/embedment information, pipe collars, junction boxes, and inlet details.
- F. Storm pipe shall be installed in accordance with NCTCOG Item 508, “Open Cut – Storm Water Conduit Installation”, except as modified or clarified below:
 - 1) Trench excavation, including embedment and backfill, are considered subsidiary to this Bid Item. The backfill of all ditches for the installation of wastewater, water, or storm sewer pipe shall be as specified and placed in layers not more than 8 inches in depth (loose measurement) and shall be compacted to at least 95 percent of maximum density. Densities shall be 95 percent of the maximum dry density at not less than optimum moisture of samples of the material as determined by the "Maximum Density Optimum Moisture Test," ASTM Designation D 698.
- G. Measurement for this bid item shall be per linear foot.
- H. Payment for this bid item shall be paid for at the unit price bid for “Class III RCP” of the diameter specified.

BID ITEM NO. 4.02 – Trench Excavation Protection

The provisions of TxDOT Item 402, “Trench Excavation Protection”, shall apply except as modified or clarified below:

- A. In addition to personnel safety, the “Trench Safety Plan”, developed by the Contractor, must provide for sheeting and shoring procedures capable of providing support of the trenches or boring pits, giving due consideration to the proximity of existing structures and other facilities along the proposed utility lines.

Belt Line Road Underground Electrical Phase I – Marsh Lane to Midway Road

- B. The cost of trench dewatering, if required, shall be subsidiary to this Bid Item.
- C. Contractor shall be paid under this bid item based on the linear foot of storm drain installed using open-cut trench method only.
- D. Measurement for this bid item shall be per linear foot.
- E. Payment for this bid item shall be paid for at the unit price bid for “Trench Excavation Protection”.

BID ITEM NO. 4.03 – 6' Standard Curb Inlet

The provisions of TxDOT Item 465, “Manholes and Inlets”, shall apply except as modified or clarified below:

- A. Concrete shall be Class ‘A’ concrete design to meet a minimum average compressive strength of 3,000 psi at 28 days.
- B. Ring and cover shall be per Town specifications.
- C. Measurement for this bid item shall be per each.
- D. Payment for this bid item shall be paid for at the unit price bid for “6' Standard Curb Inlet”.

BID ITEM NO. 4.04 – 10' Recessed Curb Inlet

The provisions of TxDOT Item 465, “Manholes and Inlets”, shall apply except as modified or clarified below:

- A. Concrete shall be Class ‘A’ concrete design to meet a minimum average compressive strength of 3,000 psi at 28 days.
- B. Ring and cover shall be per Town specifications.
- C. Measurement for this bid item shall be per each.
- D. Payment for this bid item shall be paid for at the unit price bid for “10' Recessed Curb Inlet”.

WATER IMPROVEMENTS

BID ITEM NO. 5.01 – 8" Water Line by open cut

The provisions of NCTCOG Item 501.14 "Polyvinyl Chloride (PVC) water pipe", Item 505 "Open Cut –General Conduit Installation" and Item 506 "Open Cut – Water Conduit Installation" or as otherwise specified in Town of Addison's water system requirements, shall apply.

- A. Measurement for this bid item shall be per linear foot.

Belt Line Road Underground Electrical Phase I – Marsh Lane to Midway Road

- B. Payment for this bid item shall be paid for at the unit price bid for "8" Water Line by open cut".

BID ITEM NO. 5.02 – 8" Gate Valves

The provisions of NCTCOG Item 502.6, "Valves" or as otherwise specified in Town of Addison's water system requirements, shall apply.

- A. Measurement for this bid item shall be per each.
- B. Payment for this bid item shall be paid for at the unit price bid for "8" Gate Valves".

BID ITEM NO. 5.03 – 12" Gate Valves – NOT USED

The provisions of NCTCOG Item 502.6, "Valves", or as otherwise specified in Town of Addison's water system requirements, shall apply.

- A. Measurement for this bid item shall be per each.
- B. Payment for this bid item shall be paid for at the unit price bid for "12" Gate Valves".

BID ITEM NO. 5.04 – 16" Steel Encasement Pipe – NOT USED

The provisions of NCTCOG Item 501.9 Steel Pipe and Fittings, or as otherwise specified in Town of Addison's water system requirements, shall apply.

- A. Measurement for this bid item shall be per linear foot.
- B. Payment for this bid item shall be paid for at the unit price bid for "16" Steel Encasement Pipe".

BID ITEM NO. 5.05 – 20" Butterfly Valve with 6" bypass and 6' Diameter Manhole

The provisions of NCTCOG Item 502.6 "Valves" and 502.1 "Manholes" or as otherwise specified in Town of Addison's water system requirements shall apply.

- A. Measurement for this bid item shall be per each.
- B. Use class 250B, per AWWA standard C504.
- C. Payment for this bid item shall be paid for at the unit price bid for "20" Butterfly Valve with 6" bypass and 6' Diameter Manhole".

BID ITEM NO. 5.06 – 24" Butterfly Valve with 6" bypass and 6' Diameter Manhole

Belt Line Road Underground Electrical Phase I – Marsh Lane to Midway Road

The provisions of NCTCOG Item 502.6 "Valves" and 502.1 "Manholes" or as otherwise specified in Town of Addison's water system requirements shall apply.

- A. Measurement for this bid item shall be per each.
- B. Use class 250B, per AWWA standard C504.
- C. Payment for this bid item shall be paid for at the unit price bid for "24" Butterfly Valve with 6" bypass and 6' Diameter Manhole".

BID ITEM NO. 5.07 – 12" Sanitary sewer line by open cut

The provisions of NCTCOG Item 501.15 "Polyvinyl Chloride (PVC) Pressure-Rated Pipe (SDR Series), Item 505 "Open Cut –General Conduit Installation" and Item 507 "Open Cut – Wastewater Conduit Installation" shall apply.

- A. Measurement for this bid item shall be per linear foot.
- B. Payment for this bid item shall be paid for at the unit price bid for "12" Sanitary sewer line by open cut".

BID ITEM NO. 5.08 – Trench Excavation Protection

The provisions of TxDOT Item 402, "Trench Excavation Protection", shall apply except as modified or clarified below:

- A. In addition to personnel safety, the "Trench Safety Plan", developed by the Contractor, must provide for sheeting and shoring procedures capable of providing support of the trenches or boring pits, giving due consideration to the proximity of existing structures and other facilities along the proposed utility lines.
- B. The cost of trench dewatering, if required, shall be subsidiary to this Bid Item.
- C. Contractor shall be paid under this bid item based on the linear foot of Water/Sanitary Sewer lines installed using open-cut trench method only.
- D. Measurement for this bid item shall be per linear foot.
- E. Payment for this bid item shall be paid for at the unit price bid for "Trench Excavation Protection".

ONCOR DUCT BANK

BID ITEM NO. 6.01 – 2E2 Duct Bank

The following provisions shall apply:

Belt Line Road Underground Electrical Phase I – Marsh Lane to Midway Road

- A. This item includes all labor, equipment, materials and incidentals required to provide duct bank for ONCOR in accordance with plans and specifications.
- B. Item must meet ONCOR requirements, specifications section DDS-4 UG.
- C. Refer to Duct Bank Plan and Profile for location, details and general notes.
- D. Measurement for this bid item shall be per linear foot.
- E. Payment for this bid item shall be paid for at the unit price bid for “2E2 Duct Bank”.

BID ITEM NO. 6.02 –2E4 Duct Bank

The following provisions shall apply:

- A. This item includes all labor, equipment, materials and incidentals required to provide duct bank for ONCOR in accordance with plans and specifications.
- B. Item must meet ONCOR requirements, specifications section DDS-4 UG.
- C. Refer to Duct Bank Plan and Profile for location, details and general notes.
- D. Measurement for this bid item shall be per linear foot.
- E. Payment for this bid item shall be paid for at the unit price bid for “2E4 Duct Bank”.

BID ITEM NO. 6.03 – 2E4-2E2 Duct Bank

The following provisions shall apply:

- A. This item includes all labor, equipment, materials and incidentals required to provide duct bank for ONCOR in accordance with plans and specifications.
- B. Item must meet ONCOR requirements, specifications section DDS-4 UG.
- C. Refer to Duct Bank Plan and Profile for location, details and general notes.
- D. Measurement for this bid item shall be per linear foot.
- E. Payment for this bid item shall be paid for at the unit price bid for “2E4-2E2 Duct Bank”.

BID ITEM NO. 6.04 – 4E4Duct Bank

The following provisions shall apply:

- A. This item includes all labor, equipment, materials and incidentals required to provide duct bank for ONCOR in accordance with plans and specifications.
- B. Item must meet ONCOR requirements, specifications section DDS-4 UG.
- C. Refer to Duct Bank Plan and Profile for location, details and general notes.
- D. Measurement for this bid item shall be per linear foot.

Belt Line Road Underground Electrical Phase I – Marsh Lane to Midway Road

- E. Payment for this bid item shall be paid for at the unit price bid for “4E4 Duct Bank”.

BID ITEM NO. 6.05 – 6E4 Duct Bank

The following provisions shall apply:

- A. This item includes all labor, equipment, materials and incidentals required to provide duct bank for ONCOR in accordance with plans and specifications.
- B. Item must meet ONCOR requirements, specifications section DDS-4 UG.
- C. Refer to Duct Bank Plan and Profile for location, details and general notes.
- D. Measurement for this bid item shall be per linear foot.
- E. Payment for this bid item shall be paid for at the unit price bid for “6E4 Duct Bank”.

BID ITEM NO. 6.06 – 2E6 Duct Bank

The following provisions shall apply:

- A. This item includes all labor, equipment, materials and incidentals required to provide duct bank for ONCOR in accordance with plans and specifications.
- B. Item must meet ONCOR requirements, specifications section DDS-4 UG.
- C. Refer to Duct Bank Plan and Profile for location, details and general notes.
- D. Measurement for this bid item shall be per linear foot.
- E. Payment for this bid item shall be paid for at the unit price bid for “2E6 Duct Bank”.

BID ITEM NO. 6.07 – 2E6-2E4 Duct Bank

The following provisions shall apply:

- A. This item includes all labor, equipment, materials and incidentals required to provide duct bank for ONCOR in accordance with plans and specifications.
- B. Item must meet ONCOR requirements, specifications section DDS-4 UG.
- C. Refer to Duct Bank Plan and Profile for location, details and general notes.
- D. Measurement for this bid item shall be per linear foot.
- E. Payment for this bid item shall be paid for at the unit price bid for “2E6-2E4 Duct Bank”.

BID ITEM NO. 6.08 – 4E6 Duct Bank

The following provisions shall apply:

Belt Line Road Underground Electrical Phase I – Marsh Lane to Midway Road

- A. This item includes all labor, equipment, materials and incidentals required to provide duct bank for ONCOR in accordance with plans and specifications.
- B. Item must meet ONCOR requirements, specifications section DDS-4 UG.
- C. Refer to Duct Bank Plan and Profile for location, details and general notes.
- D. Measurement for this bid item shall be per linear foot.
- E. Payment for this bid item shall be paid for at the unit price bid for “4E6 Duct Bank”.

BID ITEM NO. 6.09 – 4E6-2E4 Duct Bank

The following provisions shall apply:

- A. This item includes all labor, equipment, materials and incidentals required to provide duct bank for ONCOR in accordance with plans and specifications.
- B. Item must meet ONCOR requirements, specifications section DDS-4 UG.
- C. Refer to Duct Bank Plan and Profile for location, details and general notes.
- D. Measurement for this bid item shall be per linear foot.
- E. Payment for this bid item shall be paid for at the unit price bid for “4E6-2E4 Duct Bank”.

BID ITEM NO. 6.10 – 4E6 -2E4-2E2 Duct Bank

The following provisions shall apply:

- A. This item includes all labor, equipment, materials and incidentals required to provide duct bank for ONCOR in accordance with plans and specifications.
- B. Item must meet ONCOR requirements, specifications section DDS-4 UG.
- C. Refer to Duct Bank Plan and Profile for location, details and general notes.
- D. Measurement for this bid item shall be per linear foot.
- E. Payment for this bid item shall be paid for at the unit price bid for “4E6-2E4-2E2 Duct Bank”.

BID ITEM NO. 6.11 – 4E6-4E4 Duct Bank

The following provisions shall apply:

- A. This item includes all labor, equipment, materials and incidentals required to provide duct bank for ONCOR in accordance with plans and specifications.
- B. Item must meet ONCOR requirements, specifications section DDS-4 UG.

Belt Line Road Underground Electrical Phase I – Marsh Lane to Midway Road

- C. Refer to Duct Bank Plan and Profile for location, details and general notes.
- D. Measurement for this bid item shall be per linear foot.
- E. Payment for this bid item shall be paid for at the unit price bid for “4E6-4E4 Duct bank”.

BID ITEM NO. 6.12 – 4E6-6E4 Duct Bank

The following provisions shall apply:

- A. This item includes all labor, equipment, materials and incidentals required to provide duct bank for ONCOR in accordance with plans and specifications.
- B. Item must meet ONCOR requirements, specifications section DDS-4 UG.
- C. Refer to Duct Bank Plan and Profile for location, details and general notes.
- D. Measurement for this bid item shall be per linear foot.
- E. Payment for this bid item shall be paid for at the unit price bid for “4E6-6E4 Duct Bank”.

BID ITEM NO. 6.13 – 6E6 Duct Bank

The following provisions shall apply:

- A. This item includes all labor, equipment, materials and incidentals required to provide duct bank for ONCOR in accordance with plans and specifications.
- B. Item must meet ONCOR requirements, specifications section DDS-4 UG.
- C. Refer to Duct Bank Plan and Profile for location, details and general notes.
- D. Measurement for this bid item shall be per linear foot.
- E. Payment for this bid item shall be paid for at the unit price bid for “6E6 Duct Bank”.

BID ITEM NO. 6.14 – 8E6 Duct Bank

The following provisions shall apply:

- A. This item includes all labor, equipment, materials and incidentals required to provide duct bank for ONCOR in accordance with plans and specifications.
- B. Item must meet ONCOR requirements, specifications section DDS-4 UG.
- C. Refer to Duct Bank Plan and Profile for location, details and general notes.
- D. Measurement for this bid item shall be per linear foot.
- E. Payment for this bid item shall be paid for at the unit price bid for “8E6 Duct Bank”.

Belt Line Road Underground Electrical Phase I – Marsh Lane to Midway Road

BID ITEM NO. 6.15 – 8E6-2E4 Duct Bank

The following provisions shall apply:

- A. This item includes all labor, equipment, materials and incidentals required to provide duct bank for ONCOR in accordance with plans and specifications.
- B. Item must meet ONCOR requirements, specifications section DDS-4 UG.
- C. Refer to Duct Bank Plan and Profile for location, details and general notes.
- D. Measurement for this bid item shall be per linear foot.
- E. Payment for this bid item shall be paid for at the unit price bid for “8E6-2E4 Duct Bank”.

BID ITEM NO. 6.16 – 8E6-4E4 Duct Bank

The following provisions shall apply:

- A. This item includes all labor, equipment, materials and incidentals required to provide duct bank for ONCOR in accordance with plans and specifications.
- B. Item must meet ONCOR requirements, specifications section DDS-4 UG.
- C. Refer to Duct Bank Plan and Profile for location, details and general notes.
- D. Measurement for this bid item shall be per linear foot.
- E. Payment for this bid item shall be paid for at the unit price bid for “8E6-4E4 Duct Bank”.

BID ITEM NO. 6.17 – 12E6 Duct Bank

The following provisions shall apply:

- A. This item includes all labor, equipment, materials and incidentals required to provide duct bank for ONCOR in accordance with plans and specifications.
- B. Item must meet ONCOR requirements, specifications section DDS-4 UG.
- C. Refer to Duct Bank Plan and Profile for location, details and general notes.
- D. Measurement for this bid item shall be per linear foot.
- E. Payment for this bid item shall be paid for at the unit price bid for “12E6 Duct Bank”.

BID ITEM NO. 6.18 – 3-Way Manhole

The following provisions shall apply:

- A. This item includes all labor, equipment, materials and incidentals required to provide duct bank manholes for ONCOR in accordance with plans and specifications.

Belt Line Road Underground Electrical Phase I – Marsh Lane to Midway Road

- B. Item must meet ONCOR requirements, specifications section DDS-4 UG.
- C. Refer to Duct Bank Plan and Profile for location, details and general notes.
- D. Measurement for this bid item shall be per each.
- E. Payment for this bid item shall be paid for at the unit price bid for “3 Way Manhole”.

BID ITEM NO. 6.19 – 4-Way Manhole

The following provisions shall apply:

- A. This item includes all labor, equipment, materials and incidentals required to provide duct bank manholes for ONCOR in accordance with plans and specifications.
- B. Item must meet ONCOR requirements, specifications section DDS-4 UG.
- C. Refer to Duct Bank Plan and Profile for location, details and general notes.
- D. Measurement for this bid item shall be per each.
- E. Payment for this bid item shall be paid for at the unit price bid for “4-Way Manhole”.

BID ITEM NO. 6.20 – Double Stacked 4-Way Manhole

The following provisions shall apply:

- A. This item includes all labor, equipment, materials and incidentals required to provide duct bank manholes for ONCOR in accordance with plans and specifications.
- B. Item must meet ONCOR requirements, specifications section DDS-4 UG.
- C. Refer to Duct Bank Plan and Profile for location, details and general notes.
- D. Measurement for this bid item shall be per each.
- E. Payment for this bid item shall be paid for at the unit price bid for “Double Stacked 4-Way Manhole”.

BID ITEM NO. 6.21 – 8E6 Duct Bank (BOTC)

The following provisions shall apply:

- A. This item includes all labor, equipment, materials and incidentals required to provide duct bank for ONCOR in accordance with plans and specifications.
- B. Item must meet ONCOR requirements, specifications section DDS-4 UG.
- C. Refer to Duct Bank Plan and Profile for location, details and general notes.
- D. Measurement for this bid item shall be per linear foot.

Belt Line Road Underground Electrical Phase I – Marsh Lane to Midway Road

- E. Payment for this bid item shall be paid for at the unit price bid for “8E6 Duct Bank (BOTC).

BID ITEM NO. 6.22 – 8E6-2E4 Duct Bank (BOTC)

The following provisions shall apply:

- A. This item includes all labor, equipment, materials and incidentals required to provide duct bank for ONCOR in accordance with plans and specifications.
- B. Item must meet ONCOR requirements, specifications section DDS-4 UG.
- C. Refer to Duct Bank Plan and Profile for location, details and general notes.
- D. Measurement for this bid item shall be per linear foot.
- E. Payment for this bid item shall be paid for at the unit price bid for “8E6-2E4 Duct Bank (BOTC).

BID ITEM NO. 6.23 – Vista Gear Pad – NOT USED

The following provisions shall apply:

- A. This item includes all labor, equipment, materials and incidentals required to provide Vista Gear Pads for ONCOR in accordance with plans and specifications.
- B. Item must meet ONCOR requirements, specifications section DDS-4 UG.
- C. Refer to Duct Bank Plan and Profile for location, details and general notes.
- D. Measurement for this bid item shall be per each.
- E. Payment for this bid item shall be paid for at the unit price bid for “Vista Gear Pad”.

BID ITEM NO. 6.24 – PME Pad – NOT USED

The following provisions shall apply:

- A. This item includes all labor, equipment, materials and incidentals required to provide PME Pads for ONCOR in accordance with plans and specifications.
- B. Item must meet ONCOR requirements, specifications section DDS-4 UG.
- C. Refer to Duct Bank Plan and Profile for location, details and general notes.
- D. Measurement for this bid item shall be per each.
- E. Payment for this bid item shall be paid for at the unit price bid for “PME Pad”.

BID ITEM NO. 6.25 – Transformer Pad – NOT USED

Belt Line Road Underground Electrical Phase I – Marsh Lane to Midway Road

The following provisions shall apply:

- A. This item includes all labor, equipment, materials and incidentals required to provide Transformer Pads for ONCOR in accordance with plans and specifications.
- B. Item must meet ONCOR requirements, specifications section DDS-4 UG.
- C. Refer to Duct Bank Plan and Profile for location, details and general notes.
- D. Measurement for this bid item shall be per each.
- E. Payment for this bid item shall be paid for at the unit price bid for "Transformer Pad".

BID ITEM NO. 6.26– 36" Steel Encasement Pipe with Spacers

The following provisions shall apply:

- A. This item includes all labor, equipment, materials and incidentals required to provide 36" Steel Encasement Pipe with Spacers for ONCOR in accordance with plans and specifications.
- B. Item must meet ONCOR requirements, specifications section DDS-4 UG.
- C. Refer to Duct Bank Plan and Profile for location, details and general notes.
- D. Measurement for this bid item shall be per linear foot.
- E. Payment for this bid item shall be paid for at the unit price bid for "36" Steel Encasement Pipe with Spacers".

BID ITEM NO. 6.27 – Stainless Steel Cabinet

The following provisions shall apply:

- A. This item includes all labor, equipment, materials and incidentals required to provide Stainless Steel Cabinet for ONCOR in accordance with plans and specifications.
- B. Item must meet ONCOR requirements, specifications section DDS-4 UG.
- C. Refer to Duct Bank Plan and Profile for location, details and general notes.
- D. Measurement for this bid item shall be per each.
- E. Payment for this bid item shall be paid for at the unit price bid for "Stainless Steel Cabinet".

BID ITEM NO. 6.28 – Termination of Primary Conduit at Riser Pole

The following provisions shall apply:

Belt Line Road Underground Electrical Phase I – Marsh Lane to Midway Road

- A. This item includes all labor, equipment, materials and incidentals required to provide Termination of Primary Conduit at Riser Pole for ONCOR in accordance with plans and specifications.
- B. Item must meet ONCOR requirements, specifications section DDS-4 UG.
- C. Refer to Duct Bank Plan and Profile for location, details and general notes.
- D. Measurement for this bid item shall be per each.
- E. Payment for this bid item shall be paid for at the unit price bid for "Termination of Primary Conduit at Riser Pole".

BID ITEM NO. 6.29 – Three Phase Primary Subsurface Splice/Pull Box

The following provisions shall apply:

- A. This item includes all labor, equipment, materials and incidentals required to provide Three Phase Primary Splice/Pull Box for ONCOR in accordance with plans and specifications.
- B. Item must meet ONCOR requirements, specifications section DDS-4 UG.
- C. Refer to Duct Bank Plan and Profile for location, details and general notes.
- D. Measurement for this bid item shall be per each.
- E. Payment for this bid item shall be paid for at the unit price bid for "Three Phase Primary Splice/Pull Box".

BID ITEM NO. 6.30 – Single Phase Primary Splice/Pull Box

The following provisions shall apply:

- A. This item includes all labor, equipment, materials and incidentals required to provide Single Phase Primary Splice/Pull Box for ONCOR in accordance with plans and specifications.
- B. Item must meet ONCOR requirements, specifications section DDS-4 UG.
- C. Refer to Duct Bank Plan and Profile for location, details and general notes.
- D. Measurement for this bid item shall be per each.
- E. Payment for this bid item shall be paid for at the unit price bid for "Single Phase Primary Splice/Pull Box".

BID ITEM NO. 6.31 – Subsurface Secondary Service Box

The following provisions shall apply:

Belt Line Road Underground Electrical Phase I – Marsh Lane to Midway Road

- A. This item includes all labor, equipment, materials and incidentals required to provide Subsurface Secondary Service Box for ONCOR in accordance with plans and specifications. Item must meet ONCOR requirements, specifications section DDS-4 UG.
- B. Refer to Duct Bank Plan and Profile for location, details and general notes.
- C. Measurement for this bid item shall be per each.
- D. Payment for this bid item shall be paid for at the unit price bid for “Subsurface Secondary Service Box”.

BID ITEM NO. 6.32 – Trench Excavation Protection

The provisions of TxDOT Item 402, “Trench Excavation Protection”, shall apply except as modified or clarified below:

- A. In addition to personnel safety, the “Trench Safety Plan”, developed by the Contractor, must provide for sheeting and shoring procedures capable of providing support of the trenches or boring pits, giving due consideration to the proximity of existing structures and other facilities along the proposed utility lines.
- B. The cost of trench dewatering, if required, shall be subsidiary to this Bid Item.
- C. Contractor shall be paid under this bid item based on the linear foot of Oncor Duct Banks installed using open-cut trench method only.
- D. Measurement for this bid item shall be per linear foot.
- E. Payment for this bid item shall be paid for at the unit price bid for “Trench Excavation Protection”.

SIGNAL IMPROVEMENTS

BID ITEM NO. 7.01 – Drill Shaft Traffic Signal Pole (48")

The provisions of TxDOT Item 416, “Drilled Shaft Foundations”, shall apply except as modified or clarified below:

- A. This item includes all labor, equipment, materials, and incidentals required to provide traffic signal drill shaft in accordance with plans and specifications.
- B. Refer to Traffic Signal Plans and Construction Details for location, details, and general notes.
- C. Measurement for this bid item shall be per linear foot.
- D. Payment for this bid item shall be paid for at the unit price bid for “Drill Shaft Traffic Signal Pole (36 Inches)”.

Belt Line Road Underground Electrical Phase I – Marsh Lane to Midway Road

BID ITEM NO. 7.02 – Drill Shaft Traffic Signal Pole (36")

The provisions of TxDOT Item 416, “Drilled Shaft Foundations”, shall apply except as modified or clarified below:

- A. This item includes all labor, equipment, materials, and incidentals required to provide traffic signal drill shaft in accordance with plans and specifications.
- B. Refer to Traffic Signal Plans and Construction Details for location, details, and general notes.
- C. Measurement for this bid item shall be per linear foot.
- D. Payment for this bid item shall be paid for at the unit price bid for “Drill Shaft Traffic Signal Pole (36 Inches)”.

BID ITEM NO. 7.03 – Drill Shaft Traffic Signal Pole (30")

The provisions of TxDOT Item 416, “Drilled Shaft Foundations”, shall apply except as modified or clarified below:

- A. This item includes all labor, equipment, materials, and incidentals required to provide traffic signal drill shaft in accordance with plans and specifications.
- B. Refer to Traffic Signal Plans and Construction Details for location, details, and general notes.
- C. Measurement for this bid item shall be per linear foot.
- D. Payment for this bid item shall be paid for at the unit price bid for “Drill Shaft Traffic Signal Pole (36 Inches)”.

BID ITEM NO. 7.04 – Conduit-2" Dia (Schd 40-Pvc)

The provisions of TxDOT Item 618, “Conduit”, shall apply except as modified or clarified below:

- A. This item includes all labor, equipment, materials, and incidentals required to provide conduit in accordance with plans and specifications.
- B. Refer to Traffic Signal Plans and Construction Details for location, details, and general notes.
- C. Measurement for this bid item shall be per linear foot.
- D. Payment for this bid item shall be paid for at the unit price bid for “Conduit (SCHD 40-PVC)” of the size and type specified.

BID ITEM NO. 7.05 – Conduit-3" Dia (Schd 40-Pvc)

Belt Line Road Underground Electrical Phase I – Marsh Lane to Midway Road

The provisions of TxDOT Item 618, “Conduit”, shall apply except as modified or clarified below:

- A. This item includes all labor, equipment, materials, and incidentals required to provide conduit in accordance with plans and specifications.
- B. Refer to Traffic Signal Plans and Construction Details for location, details, and general notes.
- C. Measurement for this bid item shall be per linear foot.
- D. Payment for this bid item shall be paid for at the unit price bid for “Conduit (SCHD 40-PVC)” of the size and type specified.

BID ITEM NO. 7.06 – Conduit-4" Dia (Schd 40-Pvc)

The provisions of TxDOT Item 618, “Conduit”, shall apply except as modified or clarified below:

- A. This item includes all labor, equipment, materials, and incidentals required to provide conduit in accordance with plans and specifications.
- B. Refer to Traffic Signal Plans and Construction Details for location, details, and general notes.
- C. Measurement for this bid item shall be per linear foot.
- D. Payment for this bid item shall be paid for at the unit price bid for “Conduit (SCHD 40-PVC)” of the size and type specified.

BID ITEM NO. 7.07 – Conduit-4" Dia (Schd 40-Pvc) Bore

The provisions of TxDOT Item 618, “Conduit”, shall apply except as modified or clarified below:

- A. This item includes all labor, equipment, materials, and incidentals required to provide conduit in accordance with plans and specifications.
- B. Refer to Traffic Signal Plans and Construction Details for location, details, and general notes.
- C. Measurement for this bid item shall be per linear foot.
- D. Payment for this bid item shall be paid for at the unit price bid for “Conduit (SCHD 40-PVC)” of the size and type specified.

BID ITEM NO. 7.08 – Electric Conductor (No. 6 Bare)

Belt Line Road Underground Electrical Phase I – Marsh Lane to Midway Road

The provisions of TxDOT Item 620, “Electrical Conductors”, shall apply except as modified or clarified below:

- A. This item includes all labor, equipment, materials, and incidentals required to provide electrical conductors in accordance with plans and specifications.
- B. Refer to Traffic Signal Plans and Construction Details for location, details, and general notes.
- C. Measurement for this bid item shall be per linear foot.
- D. Payment for this bid item shall be paid for at the unit price bid for “Electric Conductor (No. 6 Bare)”.

BID ITEM NO. 7.09 – Electric Conductor (No. 6 Xhhw)

The provisions of TxDOT Item 620, “Electrical Conductors”, shall apply except as modified or clarified below:

- A. This item includes all labor, equipment, materials, and incidentals required to provide electrical conductors in accordance with plans and specifications.
- B. Refer to Traffic Signal Plans and Construction Details for location, details, and general notes.
- C. Measurement for this bid item shall be per linear foot.
- D. Payment for this bid item shall be paid for at the unit price bid for “Electric Conductor (No. 6 Bare)”.

BID ITEM NO. 7.10 – Electric Conductor (No. 8 Bare)

The provisions of TxDOT Item 620, “Electrical Conductors”, shall apply except as modified or clarified below:

- A. This item includes all labor, equipment, materials, and incidentals required to provide electrical conductors in accordance with plans and specifications.
- B. Refer to Traffic Signal Plans and Construction Details for location, details, and general notes.
- C. Measurement for this bid item shall be per linear foot.
- D. Payment for this bid item shall be paid for at the unit price bid for “Electric Conductor (No. 6 Bare)”.

BID ITEM NO. 7.11 – Tray Cable (ILSN) 3 Cndr #12

Provisions of standard Electrical code shall apply.

Belt Line Road Underground Electrical Phase I – Marsh Lane to Midway Road

BID ITEM NO. 7.12 – Ground Box, Type D

The provisions of TxDOT Item 624, “Ground Boxes”, shall apply except as modified or clarified below:

- A. This item includes all labor, equipment, materials, and incidentals required to provide ground box in accordance with plans and specifications.
- B. Refer to Traffic Signal Plans and Construction Details for location, details, and general notes.
- C. Measurement for this bid item shall be per each.
- D. Payment for this bid item shall be paid for at the unit price bid for “Ground Box Type D”.

BID ITEM NO. 7.13 – Elc Srv Ty D 120/240 70 (Ns)Ss(E)Ps(U)

The provisions of TxDOT Item 628, “Electrical Services”, shall apply except as modified or clarified below:

- A. This item includes all labor, equipment, materials, and incidentals required to provide electrical service in accordance with plans and specifications.
- B. Refer to Traffic Signal Plans and Construction Details for location, details, and general notes.
- C. Measurement for this bid item shall be per each.
- D. Payment for this bid item shall be paid for at the unit price bid for “ELEC SRV TY D 120/240 100 (NS) SS (E) PS (U)”.

BID ITEM NO. 7.14 – Furnish & Install Traffic Signal Controller Foundation

The provisions of TxDOT Item 680, “Installation of Highway Traffic Signals”, shall apply except as modified or clarified below:

- A. This item includes all labor, equipment and incidentals required to provide installation of highway traffic signals in accordance with plans and specifications.
- B. Refer to Traffic Signal Plans and Construction Details for location, details and general notes.
- C. Measurement for this bid item shall be per each.
- D. Payment for this bid item shall be paid for at the unit price bid for “Furnish and Install Traffic Signal Controller Foundation”.

BID ITEM NO. 7.15 – Relocate Existing Traffic Signal Controller And Cabinet

Belt Line Road Underground Electrical Phase I – Marsh Lane to Midway Road

The provisions of TxDOT Item 680, “Installation of Highway Traffic Signals”, shall apply except as modified or clarified below:

- A. This item includes all labor, equipment and incidentals required to provide installation of highway traffic signals in accordance with plans and specifications.
- B. Refer to Traffic Signal Plans and Construction Details for location, details and general notes.
- C. Measurement for this bid item shall be per each.
- D. Payment for this bid item shall be paid for at the unit price bid for “Relocate Existing Traffic Signal Controller and Cabinet.

BID ITEM NO. 7.16 – Furnish & Install Traffic Signal Controller, Cabinet and Foundation

The provisions of TxDOT Item 680, “Installation of Highway Traffic Signals”, shall apply except as modified or clarified below:

- A. This item includes all labor, equipment and incidentals required to provide installation of highway traffic signals in accordance with plans and specifications.
- B. Refer to Traffic Signal Plans and Construction Details for location, details and general notes.
- C. Measurement for this bid item shall be per each.
- D. Payment for this bid item shall be paid for at the unit price bid for “Furnish and Install Traffic Signal Controller, Cabinet and Foundation”.

BID ITEM NO. 7.17 – Backplate (12" - 3 Section Head)

The provisions of TxDOT Item 682, “Vehicle and Pedestrian Signal Heads”, shall apply except as modified or clarified below:

- A. This item includes all labor, equipment, materials, and incidentals required to provide vehicle sections in accordance with plans and specifications.
- B. Refer to Traffic Signal Plans and Construction Details for location, details, and general notes.
- C. Measurement for this bid item shall be per each.
- D. Payment for this bid item shall be paid for at the unit price bid.

BID ITEM NO. 7.18 – Backplate (12" - 4 Section Head)

Belt Line Road Underground Electrical Phase I – Marsh Lane to Midway Road

The provisions of TxDOT Item 682, “Vehicle and Pedestrian Signal Heads”, shall apply except as modified or clarified below:

- A. This item includes all labor, equipment, materials, and incidentals required to provide vehicle sections in accordance with plans and specifications.
- B. Refer to Traffic Signal Plans and Construction Details for location, details, and general notes.
- C. Measurement for this bid item shall be per each.
- D. Payment for this bid item shall be paid for at the unit price bid.

BID ITEM NO. 7.19 – Backplate (12” HAWK Assembly Section Head)

The provisions of TxDOT Item 682, “Vehicle and Pedestrian Signal Heads”, shall apply except as modified or clarified below:

- A. This item includes all labor, equipment, materials, and incidentals required to provide vehicle sections in accordance with plans and specifications.
- B. Refer to Traffic Signal Plans and Construction Details for location, details, and general notes.
- C. Measurement for this bid item shall be per each.
- D. Payment for this bid item shall be paid for at the unit price bid.

BID ITEM NO. 7.20 – Ped Sig Sec (12”) Led (2 Indications) W/Countdown

The provisions of TxDOT Item 682, “Vehicle and Pedestrian Signal Heads”, shall apply except as modified or clarified below:

- A. This item includes all labor, equipment, materials, and incidentals required to provide vehicle sections in accordance with plans and specifications.
- B. Refer to Traffic Signal Plans and Construction Details for location, details, and general notes.
- C. Measurement for this bid item shall be per each.
- D. Payment for this bid item shall be paid for at the unit price bid.

BID ITEM NO. 7.21 – Vehicle Signal Section (12" - Led Green/Yellow Bi-Model Arrow)

The provisions of TxDOT Item 682, “Vehicle and Pedestrian Signal Heads”, shall apply except as modified or clarified below:

- A. This item includes all labor, equipment, materials, and incidentals required to provide vehicle sections in accordance with plans and specifications.

Belt Line Road Underground Electrical Phase I – Marsh Lane to Midway Road

- B. Refer to Traffic Signal Plans and Construction Details for location, details, and general notes.
- C. Measurement for this bid item shall be per each.
- D. Payment for this bid item shall be paid for at the unit price bid.

BID ITEM NO. 7.22 – Vehicle Signal Section (12" - Led Green)

The provisions of TxDOT Item 682, “Vehicle and Pedestrian Signal Heads”, shall apply except as modified or clarified below:

- A. This item includes all labor, equipment, materials, and incidentals required to provide vehicle sections in accordance with plans and specifications.
- B. Refer to Traffic Signal Plans and Construction Details for location, details, and general notes.
- C. Measurement for this bid item shall be per each.
- D. Payment for this bid item shall be paid for at the unit price bid.

BID ITEM NO. 7.23 – Vehicle Signal Section (12" - Led Yellow)

The provisions of TxDOT Item 682, “Vehicle and Pedestrian Signal Heads”, shall apply except as modified or clarified below:

- A. This item includes all labor, equipment, materials, and incidentals required to provide vehicle sections in accordance with plans and specifications.
- B. Refer to Traffic Signal Plans and Construction Details for location, details, and general notes.
- C. Measurement for this bid item shall be per each.
- D. Payment for this bid item shall be paid for at the unit price bid.

BID ITEM NO. 7.24 – Vehicle Signal Section (12" - Led Red)

The provisions of TxDOT Item 682, “Vehicle and Pedestrian Signal Heads”, shall apply except as modified or clarified below:

- A. This item includes all labor, equipment, materials, and incidentals required to provide vehicle sections in accordance with plans and specifications.
- B. Refer to Traffic Signal Plans and Construction Details for location, details, and general notes.
- C. Measurement for this bid item shall be per each.
- D. Payment for this bid item shall be paid for at the unit price bid.

Belt Line Road Underground Electrical Phase I – Marsh Lane to Midway Road

BID ITEM NO. 7.25 – Traffic Signal Cable - Type A (20 Cond-14 Awg)

The provisions of TxDOT Item 684, “Traffic Signal Cables”, shall apply except as modified or clarified below:

- A. This item includes all labor, equipment, materials, and incidentals required to provide traffic signal cable in accordance with plans and specifications.
- B. Refer to Traffic Signal Plans and Construction Details for location, details, and general notes.
- C. Measurement for this bid item shall be per linear foot.
- D. Payment for this bid item shall be paid for at the unit price bid for “Traffic Signal Cable – Type A (20 Conductor – 14 AWG)”.

BID ITEM NO. 7.26 – Traffic Signal Cable - Type A (7 Cond-14 Awg)

The provisions of TxDOT Item 684, “Traffic Signal Cables”, shall apply except as modified or clarified below:

- A. This item includes all labor, equipment, materials, and incidentals required to provide traffic signal cable in accordance with plans and specifications.
- B. Refer to Traffic Signal Plans and Construction Details for location, details, and general notes.
- C. Measurement for this bid item shall be per linear foot.
- D. Payment for this bid item shall be paid for at the unit price bid for “Traffic Signal Cable – Type A (7 Conductor – 14 AWG)”.

BID ITEM NO. 7.27 – Traffic Signal Cable - Type A (5 Cond-14 Awg)

The provisions of TxDOT Item 684, “Traffic Signal Cables”, shall apply except as modified or clarified below:

- A. This item includes all labor, equipment, materials, and incidentals required to provide traffic signal cable in accordance with plans and specifications.
- B. Refer to Traffic Signal Plans and Construction Details for location, details, and general notes.
- C. Measurement for this bid item shall be per linear foot.
- D. Payment for this bid item shall be paid for at the unit price bid for “Traffic Signal Cable – Type A (5 Conductor – 14 AWG)”.

BID ITEM NO. 7.28 – Traffic Signal Cable - Type A (2 Cond-14 Awg)

Belt Line Road Underground Electrical Phase I – Marsh Lane to Midway Road

The provisions of TxDOT Item 684, “Traffic Signal Cables”, shall apply except as modified or clarified below:

- A. This item includes all labor, equipment, materials, and incidentals required to provide traffic signal cable in accordance with plans and specifications.
- B. Refer to Traffic Signal Plans and Construction Details for location, details, and general notes.
- C. Measurement for this bid item shall be per linear foot.
- D. Payment for this bid item shall be paid for at the unit price bid for “Traffic Signal Cable – Type A (2 Conductor – 14 AWG)”.

BID ITEM NO. 7.29 – Traffic Signal Pole, Mast Arm Assembly With ILSN (24 Ft)

The provisions of TxDOT Item 686, “Traffic Signal Pole Assemblies (Steel)”, shall apply except as modified or clarified below:

- A. This item includes all labor, equipment, materials, and incidentals required to provide traffic signal pole mast arm assembly in accordance with plans and specifications.
- B. Refer to Traffic Signal Plans and Construction Details for location, details, and general notes.
- C. Measurement for this bid item shall be per each.
- D. Payment for this bid item shall be paid for at the unit price bid for “Traffic Signal Pole, Mast Arm Assembly with ILSN” of the size specified.

BID ITEM NO. 7.30 – Traffic Signal Pole, Mast Arm Assembly With ILSN (28 Ft)

The provisions of TxDOT Item 686, “Traffic Signal Pole Assemblies (Steel)”, shall apply except as modified or clarified below:

- A. This item includes all labor, equipment, materials, and incidentals required to provide traffic signal pole mast arm assembly in accordance with plans and specifications.
- B. Refer to Traffic Signal Plans and Construction Details for location, details, and general notes.
- C. Measurement for this bid item shall be per each.
- D. Payment for this bid item shall be paid for at the unit price bid for “Traffic Signal Pole, Mast Arm Assembly with ILSN” of the size specified.

BID ITEM NO. 7.31– Traffic Signal Pole, Mast Arm Assembly With ILSN (36 Ft)

Belt Line Road Underground Electrical Phase I – Marsh Lane to Midway Road

The provisions of TxDOT Item 686, “Traffic Signal Pole Assemblies (Steel)”, shall apply except as modified or clarified below:

- A. This item includes all labor, equipment, materials, and incidentals required to provide traffic signal pole mast arm assembly in accordance with plans and specifications.
- B. Refer to Traffic Signal Plans and Construction Details for location, details, and general notes.
- C. Measurement for this bid item shall be per each.
- D. Payment for this bid item shall be paid for at the unit price bid for “Traffic Signal Pole, Mast Arm Assembly with ILSN” of the size specified.

BID ITEM NO. 7.32– Traffic Signal Pole, Mast Arm Assembly With ILSN (40 Ft)

The provisions of TxDOT Item 686, “Traffic Signal Pole Assemblies (Steel)”, shall apply except as modified or clarified below:

- A. This item includes all labor, equipment, materials, and incidentals required to provide traffic signal pole mast arm assembly in accordance with plans and specifications.
- B. Refer to Traffic Signal Plans and Construction Details for location, details, and general notes.
- C. Measurement for this bid item shall be per each.
- D. Payment for this bid item shall be paid for at the unit price bid for “Traffic Signal Pole, Mast Arm Assembly with ILSN” of the size specified.

BID ITEM NO. 7.33 – Traffic Signal Pole, Mast Arm Assembly With ILSN (48 Ft)

The provisions of TxDOT Item 686, “Traffic Signal Pole Assemblies (Steel)”, shall apply except as modified or clarified below:

- A. This item includes all labor, equipment, materials, and incidentals required to provide traffic signal pole mast arm assembly in accordance with plans and specifications.
- B. Refer to Traffic Signal Plans and Construction Details for location, details, and general notes.
- C. Measurement for this bid item shall be per each.
- D. Payment for this bid item shall be paid for at the unit price bid for “Traffic Signal Pole, Mast Arm Assembly with ILSN” of the size specified.

BID ITEM NO. 7.34– Traffic Signal Pole, Mast Arm Assembly With ILSN (55Ft)

Belt Line Road Underground Electrical Phase I – Marsh Lane to Midway Road

The provisions of TxDOT Item 686, “Traffic Signal Pole Assemblies (Steel)”, shall apply except as modified or clarified below:

- A. This item includes all labor, equipment, materials, and incidentals required to provide traffic signal pole mast arm assembly in accordance with plans and specifications.
- B. Refer to Traffic Signal Plans and Construction Details for location, details, and general notes.
- C. Measurement for this bid item shall be per each.
- D. Payment for this bid item shall be paid for at the unit price bid for “Traffic Signal Pole, Mast Arm Assembly with ILSN” of the size specified.

BID ITEM NO. 7.35– Traffic Signal Pole, Mast Arm Assembly With ILSN (60Ft)

The provisions of TxDOT Item 686, “Traffic Signal Pole Assemblies (Steel)”, shall apply except as modified or clarified below:

- A. This item includes all labor, equipment, materials, and incidentals required to provide traffic signal pole mast arm assembly in accordance with plans and specifications.
- B. Refer to Traffic Signal Plans and Construction Details for location, details, and general notes.
- C. Measurement for this bid item shall be per each.
- D. Payment for this bid item shall be paid for at the unit price bid for “Traffic Signal Pole, Mast Arm Assembly with ILSN” of the size specified.

BID ITEM NO. 7.36– Ped Detect (2" Push Button)

The provisions of TxDOT Item 688, “Pedestrian Detectors and Vehicle Loop Detectors”, shall apply except as modified or clarified below:

- A. This item includes all labor, equipment, materials and incidentals required to provide pedestrian detectors in accordance with plans and specifications.
- B. Refer to Traffic Signal Plans and Construction Details for location, details and general notes.
- C. Measurement for this bid item shall be per each.
- D. Payment for this bid item shall be paid for at the unit price bid for “Ped Detect (2 Inch Push BTN)”.

BID ITEM NO. 7.37 – Vivds Processor System

Belt Line Road Underground Electrical Phase I – Marsh Lane to Midway Road

The provisions of TxDOT Special Specification 6266, “Video Imaging Vehicle Detection System”, shall apply except as modified or clarified below:

- A. This item includes all labor, equipment, materials, and incidentals required to provide video imaging vehicle detection system in accordance with plans and specifications.
- B. Refer to Traffic Signal Plans and Construction Details for location, details, and general notes.
- C. Measurement for this bid item shall be linear foot (VIVDS communication cable) or each (VIVDS processor system, camera assembly, and setup system).
- D. Payment for this bid item shall be paid for at the unit price bid for “VIVDS” of the type specified.

BID ITEM NO. 7.38 – Vivds Camera Assembly

The provisions of TxDOT Special Specification 6266, “Video Imaging Vehicle Detection System”, shall apply except as modified or clarified below:

- A. This item includes all labor, equipment, materials, and incidentals required to provide video imaging vehicle detection system in accordance with plans and specifications.
- B. Refer to Traffic Signal Plans and Construction Details for location, details, and general notes.
- C. Measurement for this bid item shall be linear foot (VIVDS communication cable) or each (VIVDS processor system, camera assembly, and setup system).
- D. Payment for this bid item shall be paid for at the unit price bid for “VIVDS” of the type specified.

BID ITEM NO. 7.39 – Vivds Setup System

The provisions of TxDOT Special Specification 6266, “Video Imaging Vehicle Detection System”, shall apply except as modified or clarified below:

- A. This item includes all labor, equipment, materials, and incidentals required to provide video imaging vehicle detection system in accordance with plans and specifications.
- B. Refer to Traffic Signal Plans and Construction Details for location, details, and general notes.
- C. Measurement for this bid item shall be linear foot (VIVDS communication cable) or each (VIVDS processor system, camera assembly, and setup system).
- D. Payment for this bid item shall be paid for at the unit price bid for “VIVDS” of the type specified.

BID ITEM NO. 7.40 – Salvage Traffic Signal per Intersection

Belt Line Road Underground Electrical Phase I – Marsh Lane to Midway Road

The provisions of TxDOT Special Specification 6007, “Removing Traffic Signals”, shall apply except as modified or clarified below:

- A. This item includes all labor, equipment, materials, and incidentals required to provide removal of traffic signals in accordance with plans and specifications.
- B. Refer to Traffic Signal Plans and Construction Details for location, details, and general notes.
- C. Contractor is responsible for condition of removed traffic signals.
- D. Measurement for this bid item shall be per each intersection.
- E. Payment for this bid item shall be paid for at the unit price bid for “Salvage Traffic Signal per Intersection”.

BID ITEM NO. 7.41 – Opticom Cable (includes 12 sensors)

The following provisions shall apply:

- A. This item includes all labor, equipment, materials, and incidentals required to provide video imaging vehicle detection system in accordance with plans and specifications.
- B. Refer to Traffic Signal Plans and Construction Details for location, details, and general notes.
- C. Measurement for this bid item shall be linear foot (cable) or each (sensors).
- D. Payment for this bid item shall be paid for at the unit price bid for “Opticom Sensors” and “Opticom Cable”.

BID ITEM NO. 7.42 – Vivds Cable

The following provisions shall apply:

- A. This item includes all labor, equipment, materials, and incidentals required to provide video imaging vehicle detection system in accordance with plans and specifications.
- B. Refer to Traffic Signal Plans and Construction Details for location, details, and general notes.
- C. Measurement for this bid item shall be linear foot .
- D. Payment for this bid item shall be paid for at the unit price bid for “Vivds Cable”.

BID ITEM NO. 7.43 – Aluminum Sign (Mast Arm Mount)

The following provisions shall apply:

Belt Line Road Underground Electrical Phase I – Marsh Lane to Midway Road

- A. This item includes all labor, equipment, materials, and incidentals required to provide Aluminum Signs in accordance with plans and specifications.
- B. Refer to Traffic Signal Plans and Construction Details for location, details, and general notes.
- C. Measurement for this bid item shall be per each.
- D. Payment for this bid item shall be paid for at the unit price bid for “Aluminum Signs (Mast Arm Mount)”.

**HARDSCAPE IMPROVEMENTS/ENHANCED AREAS
(All applicable provisions of section TS shall apply to bid items below)**

BID ITEM NO. 8.01 – Standard Grey Concrete w/ Acid Etch Finish (4" Thick)

BID ITEM NO. 8.02 – Decorative Pavers

Reference Specification Section 32-14-16.

BID ITEM NO. 8.03 – 24x36 Detectable Warning Plate "Armorcast wet set panels".

LANDSCAPE IMPROVEMENTS

BID ITEM NO. 9.01 – 6" Topsoil Import for Turf Area

The provisions of TxDOT Item 160, “Topsoil”, shall apply except as modified or clarified below:

- A. This item includes all labor, equipment, materials and incidentals required to provide topsoil in accordance with plans and specifications.
- B. Measurement for this bid item shall be per cubic yard in vehicles at point of delivery.
- C. Payment for this bid item shall be paid for at the unit price bid for "6" Topsoil Import for Turf Area” for the location specified.

BID ITEM NO. 9.02 – Soil Prep Material and Landscape Grading

The following provisions shall apply:

- A. Refer to Technical Landscape Specification Section 32-9119, “Landscape Grading” for additional requirements.

Belt Line Road Underground Electrical Phase I – Marsh Lane to Midway Road

- B. Refer to Landscape Plans for location, details, and general notes.
- C. This item includes all labor, equipment, materials, excavating, compacting, and incidentals required to complete the work in accordance with plans and specifications.
- D. Measurement for this bid item shall be Square Foot.
- E. Payment for this bid item shall be paid for at the unit price bid for “Soil Prep Material and Landscape Grading” for the location specified.

BID ITEM NO. 9.03 – Common Bermuda 'Mid Iron' Sod

The following provisions shall apply:

- A. Refer to Technical Landscape Specification Section 32-9223, “Sodding” for additional requirements.
- B. Refer to Landscape Plans for location, details, and general notes.
- C. This item includes all labor, equipment, materials, excavating, compacting, and incidentals required to complete the work in accordance with plans and specifications.
- D. Measurement for this bid item shall be per square foot.
- E. Payment for this bid item shall be paid for at the unit price bid for "Common Bermuda Mid Iron Sod"

BID ITEM NO. 9.04 – Turf Spray Irrigation Repair

The following provisions shall apply:

- A. Refer to Technical Landscape Specification Section 32-8000, “Town of Addison Landscape Irrigation Specifications,” for additional requirements.
- B. Refer to Irrigation Plans for location, details, and general notes.
- C. This item includes all labor, equipment, materials, excavating, compacting, and incidentals required to complete the work in accordance with plans and specifications.
- D. Measurement for this bid item shall be by the square foot as measured on the plans.
- E. Payment for this bid item shall be paid for at the unit price bid for “Turf Spray Irrigation Repair”.

BID ITEM NO. 9.05 – Tree Demolition

The provisions of TxDOT Item 752, “Tree and Brush Removal” shall apply except as modified or clarified below:

Belt Line Road Underground Electrical Phase I – Marsh Lane to Midway Road

- A. Refer to Removal Plans for locations, general notes, and details of trees to be removed and/or replaced.
- B. Trees to be replaced shall comply with the requirements of Landscape Architecture Specification 32-9300.
- C. Measurement for this bid item shall be per each.
- D. Payment for this bid item shall be paid for at the unit price bid for “Tree Demolition”.

BID ITEM NO. 9.06– 90 Day Establishment Period

The following provisions shall apply:

- A. Refer to Technical Landscape Specification Section 32-0190, “90 Day Establishment Planting” for additional requirements.
- B. Refer to Construction Plans for details, and general notes.
- C. This item includes all labor, equipment, materials, and incidentals required to implement landscape maintenance program for a period of 90days after planting in accordance with plans and specifications.
- D. Measurement for this bid item shall be lump sum.
- E. Payment for this bid item shall be paid for at the unit price bid for “90 Day Establishment Period”.

BID ITEM NO. 9.07 – 1 Year Maintenance

The following provisions shall apply:

- A. Refer to Technical Landscape Specification Section 32-0192, “Landscape Maintenance 1 Year” for additional requirements.
- B. Refer to Construction Plans for details, and general notes.
- C. This item includes all labor, equipment, materials, and incidentals required to implement landscape maintenance program for a period of 1 year after final acceptance from Town in accordance with plans and specifications.
- D. Measurement for this bid item shall be lump sum.
- E. Payment for this bid item shall be paid for at the unit price bid for Implementation of Landscape Maintenance Program for a Period of (1) Year from Date of Final Acceptance.

BID ITEM NO. 9.08 – Median Repair: Shrubs, Irrigation, Prep, mulch and trees –NOT USED

Belt Line Road Underground Electrical Phase I – Marsh Lane to Midway Road

The following provisions shall apply:

- A. Refer to Technical Landscape Specification Section 32-9300, “Landscape Planting,” for additional requirements.
- B. Refer to Landscape Plans for location, details, and general notes.
- C. This item includes all labor, equipment, materials, excavating, compacting, repairs, replacements and incidentals required to complete the work in accordance with plans and specifications.
- D. Measurement for this bid item shall be square foot.
- E. Payment for this bid item shall be paid for at the unit price bid for Median Repair.

TELECOM DUCT BANK (AT&T, TWC AND FIBERLIGHT)

BID ITEM NO. 10.01 – AT&T Handhole

The following provisions shall apply:

- A. This item includes all labor, equipment, materials and incidentals required to provide duct bank handholes for AT&T in accordance with plans and specifications.
- B. Item must meet AT&T requirements.
- C. Refer to Telecom Duct Bank Plan for location, details and general notes.
- D. Measurement for this bid item shall be per each.
- E. Payment for this bid item shall be paid for at the unit price bid for “AT&T Handhole”.

BID ITEM NO. 10.02 – TWC Manhole

The following provisions shall apply:

- A. This item includes all labor, equipment, materials and incidentals required to provide duct bank manholes for TWC in accordance with plans and specifications.
- B. Item must meet TWC requirements.
- C. Refer to Telecom Duct Bank Plan for location, details and general notes.
- D. Measurement for this bid item shall be per each.
- E. Payment for this bid item shall be paid for at the unit price bid for “TWC Manhole”.

BID ITEM NO. 10.03 – TWC Vault/Pedestal

The following provisions shall apply:

Belt Line Road Underground Electrical Phase I – Marsh Lane to Midway Road

- A. This item includes all labor, equipment, materials and incidentals required to provide duct bank Vault/Pedestal for TWC in accordance with plans and specifications.
- B. Item must meet TWC requirements.
- C. Refer to Telecom Duct Bank Plan for location, details and general notes.
- D. Measurement for this bid item shall be per each.
- E. Payment for this bid item shall be paid for at the unit price bid for “TWC Vault/Pedestal”.

BID ITEM NO. 10.04 – Fiberlight Handhole

The following provisions shall apply:

- A. This item includes all labor, equipment, (materials provided by Fiberlight) and incidentals required to provide duct bank Handhole for Fiberlight in accordance with plans and specifications.
- B. Item must meet Fiberlight requirements.
- C. Refer to Telecom Duct Bank Plan for location, details and general notes.
- D. Measurement for this bid item shall be per each.
- E. Payment for this bid item shall be paid for at the unit price bid for “Fiberlight Handhole”.

BID ITEM NO. 10.05 – 2C4 Duct Bank

The following provisions shall apply:

- A. This item includes all labor, equipment, materials and incidentals required to provide duct bank for ONCOR and Telecoms in accordance with plans and specifications.
- B. Item must meet ONCOR requirements, specifications section DDS-4 UG.
- C. Refer to Telecom Duct Bank Plan for location, details and general notes.
- D. Measurement for this bid item shall be per linear foot.
- E. Payment for this bid item shall be paid for at the unit price bid for “2C4 Duct Bank”.

BID ITEM NO. 10.06 – 4C4 Duct Bank

The following provisions shall apply:

- A. This item includes all labor, equipment, materials and incidentals required to provide duct bank for ONCOR and Telecoms in accordance with plans and specifications.

Belt Line Road Underground Electrical Phase I – Marsh Lane to Midway Road

- B. Item must meet ONCOR requirements, specifications section DDS-4 UG.
- C. Refer to Telecom Duct Bank Plan for location, details and general notes.
- D. Measurement for this bid item shall be per linear foot.
- E. Payment for this bid item shall be paid for at the unit price bid for “4C4 Duct Bank”.

BID ITEM NO. 10.07 – 4C4-2E4 Duct Bank

The following provisions shall apply:

- A. This item includes all labor, equipment, materials and incidentals required to provide duct bank for ONCOR and Telecoms in accordance with plans and specifications.
- B. Item must meet ONCOR requirements, specifications section DDS-4 UG.
- C. Refer to Telecom Duct Bank Plan for location, details and general notes.
- D. Measurement for this bid item shall be per linear foot.
- E. Payment for this bid item shall be paid for at the unit price bid for “4C4-2E4 Duct Bank”.

BID ITEM NO. 10.08 – 6C4 Duct Bank

The following provisions shall apply:

- A. This item includes all labor, equipment, materials and incidentals required to provide duct bank for ONCOR and Telecoms in accordance with plans and specifications.
- B. Item must meet ONCOR requirements, specifications section DDS-4 UG.
- C. Refer to Telecom Duct Bank Plan for location, details and general notes.
- D. Measurement for this bid item shall be per linear foot.
- E. Payment for this bid item shall be paid for at the unit price bid for “6C4 Duct Bank”.

BID ITEM NO. 10.09 – 6C4 Duct Bank (BOTO)

The following provisions shall apply:

- A. This item includes all labor, equipment, materials and incidentals required to provide duct bank for ONCOR and Telecoms in accordance with plans and specifications.
- B. Item must meet ONCOR requirements, specifications section DDS-4 UG.
- C. Refer to Telecom Duct Bank Plan for location, details and general notes.
- D. Measurement for this bid item shall be per linear foot.

Belt Line Road Underground Electrical Phase I – Marsh Lane to Midway Road

- E. Payment for this bid item shall be paid for at the unit price bid for “6C4 Duct Bank (BOTOC)”.

BID ITEM NO. 10.10 – 6C4/2C3 Duct Bank

The following provisions shall apply:

- A. This item includes all labor, equipment, materials and incidentals required to provide duct bank for ONCOR and Telecoms in accordance with plans and specifications.
- B. Item must meet ONCOR requirements, specifications section DDS-4 UG.
- C. Refer to Telecom Duct Bank Plan for location, details and general notes.
- D. Measurement for this bid item shall be per linear foot.
- E. Payment for this bid item shall be paid for at the unit price bid for “6C4/2C3 Duct Bank”.

BID ITEM NO. 10.11 – 6C4-2E2 Duct Bank

The following provisions shall apply:

- A. This item includes all labor, equipment, materials and incidentals required to provide duct bank for ONCOR and Telecoms in accordance with plans and specifications.
- B. Item must meet ONCOR requirements, specifications section DDS-4 UG.
- C. Refer to Telecom Duct Bank Plan for location, details and general notes.
- D. Measurement for this bid item shall be per linear foot.
- E. Payment for this bid item shall be paid for at the unit price bid for “6C4-2E2 Duct Bank”.

BID ITEM NO. 10.12 – 6C4-2E4 Duct Bank

The following provisions shall apply:

- A. This item includes all labor, equipment, materials and incidentals required to provide duct bank for ONCOR and Telecoms in accordance with plans and specifications.
- B. Item must meet ONCOR requirements, specifications section DDS-4 UG.
- C. Refer to Telecom Duct Bank Plan for location, details and general notes.
- D. Measurement for this bid item shall be per linear foot.
- E. Payment for this bid item shall be paid for at the unit price bid for “6C4-2E4 Duct Bank”.

BID ITEM NO. 10.13– 6C4-4E4 Duct Bank

Belt Line Road Underground Electrical Phase I – Marsh Lane to Midway Road

The following provisions shall apply:

- A. This item includes all labor, equipment, materials and incidentals required to provide duct bank for ONCOR and Telecoms in accordance with plans and specifications.
- B. Item must meet ONCOR requirements, specifications section DDS-4 UG.
- C. Refer to Telecom Duct Bank Plan for location, details and general notes.
- D. Measurement for this bid item shall be per linear foot.
- E. Payment for this bid item shall be paid for at the unit price bid for “6C4-4E4 Duct Bank”.

BID ITEM NO. 10.14– 6C4-6E4 Duct Bank

The following provisions shall apply:

- A. This item includes all labor, equipment, materials and incidentals required to provide duct bank for ONCOR and Telecoms in accordance with plans and specifications.
- B. Item must meet ONCOR requirements, specifications section DDS-4 UG.
- C. Refer to Telecom Duct Bank Plan for location, details and general notes.
- D. Measurement for this bid item shall be per linear foot.
- E. Payment for this bid item shall be paid for at the unit price bid for “6C4-6E4 Duct Bank”.

BID ITEM NO. 10.15– 8C4 Duct Bank

The following provisions shall apply:

- A. This item includes all labor, equipment, materials and incidentals required to provide duct bank for ONCOR and Telecoms in accordance with plans and specifications.
- B. Item must meet ONCOR requirements, specifications section DDS-4 UG.
- C. Refer to Telecom Duct Bank Plan for location, details and general notes.
- D. Measurement for this bid item shall be per linear foot.
- E. Payment for this bid item shall be paid for at the unit price bid for “8C4 Duct Bank”.

BID ITEM NO. 10.16– 8C4- 2E2 Duct Bank

The following provisions shall apply:

- A. This item includes all labor, equipment, materials and incidentals required to provide duct bank for ONCOR and Telecoms in accordance with plans and specifications.
- B. Item must meet ONCOR requirements, specifications section DDS-4 UG.

Belt Line Road Underground Electrical Phase I – Marsh Lane to Midway Road

- C. Refer to Telecom Duct Bank Plan for location, details and general notes.
- D. Measurement for this bid item shall be per linear foot.
- E. Payment for this bid item shall be paid for at the unit price bid for “8C4-2E2 Duct Bank”.

BID ITEM NO. 10.17– 8C4-2C3- 2E4 Duct Bank

The following provisions shall apply:

- A. This item includes all labor, equipment, materials and incidentals required to provide duct bank for ONCOR and Telecoms in accordance with plans and specifications.
- B. Item must meet ONCOR requirements, specifications section DDS-4 UG.
- C. Refer to Telecom Duct Bank Plan for location, details and general notes.
- D. Measurement for this bid item shall be per linear foot.
- E. Payment for this bid item shall be paid for at the unit price bid for “8C4-2C3-2E4 Duct Bank”.

BID ITEM NO. 10.18– 8C4-2E4 Duct Bank

The following provisions shall apply:

- A. This item includes all labor, equipment, materials and incidentals required to provide duct bank for ONCOR and Telecoms in accordance with plans and specifications.
- B. Item must meet ONCOR requirements, specifications section DDS-4 UG.
- C. Refer to Telecom Duct Bank Plan for location, details and general notes.
- D. Measurement for this bid item shall be per linear foot.
- E. Payment for this bid item shall be paid for at the unit price bid for “8C4-2E4 Duct Bank”.

BID ITEM NO. 10.19– 8C4-4E4 Duct Bank

The following provisions shall apply:

- A. This item includes all labor, equipment, materials and incidentals required to provide duct bank for ONCOR and Telecoms in accordance with plans and specifications.
- B. Item must meet ONCOR requirements, specifications section DDS-4 UG.
- C. Refer to Telecom Duct Bank Plan for location, details and general notes.
- D. Measurement for this bid item shall be per linear foot.
- E. Payment for this bid item shall be paid for at the unit price bid for “8C4-4E4 Duct Bank”.

Belt Line Road Underground Electrical Phase I – Marsh Lane to Midway Road

BID ITEM NO. 10.20– 10C4 Duct Bank

The following provisions shall apply:

- A. This item includes all labor, equipment, materials and incidentals required to provide duct bank for ONCOR and Telecoms in accordance with plans and specifications.
- B. Item must meet ONCOR requirements, specifications section DDS-4 UG.
- C. Refer to Telecom Duct Bank Plan for location, details and general notes.
- D. Measurement for this bid item shall be per linear foot.
- E. Payment for this bid item shall be paid for at the unit price bid for “10C4 Duct Bank”.

BID ITEM NO. 10.21 – Riser on Existing Power Pole

The following provisions shall apply:

- A. This item includes all labor, equipment, materials and incidentals required to provide riser on existing power pole for telecoms in accordance with plans and specifications.
- B. Item must meet ONCOR requirements.
- C. Refer to Telecom Duct Bank Plan for location, details and general notes.
- D. Measurement for this bid item shall be per each.
- E. Payment for this bid item shall be paid for at the unit price bid for “Riser on Existing Power Pole”.

BID ITEM NO. 10.22 – Connect to Existing Underground Line

The following provisions shall apply:

- A. This item includes all labor, equipment, materials and incidentals required to provide connection to existing underground line in accordance with plans and specifications.
- B. Item must meet ONCOR requirements.
- C. Refer to Telecom Duct Bank Plan for location, details and general notes.
- D. Measurement for this bid item shall be per each.
- E. Payment for this bid item shall be paid for at the unit price bid for “Connect to Existing Underground Line”.

BID ITEM NO. 10.23 – Utility Adjustment Allowance

Belt Line Road Underground Electrical Phase I – Marsh Lane to Midway Road

The following provisions shall apply:

- A. This item includes all labor, equipment, materials and incidentals required to provide miscellaneous utility adjustments in accordance with plans and specifications.
- B. This item provides for an allowance to be used at the discretion of the Town of Addison and the Engineer.
- C. Each time a conflict has been determined the contractor shall notify Town and Engineer and request resolution prior to proceeding with any work.
- D. Measurement and payment will be negotiated per conflict occurrence once details for conflict resolution have been determined by the Engineer. All pricing shall be based on time and materials.

ADD/ALTERNATE BID ITEMS

BID ITEMS NO. 11.01-11.06

These items are for potential tree replacements to be used at the discretion of Addison Parks and Recreation staff. Locations will be determined for replacement trees as needed.

SECTION PS
PROJECT SIGN

PROJECT SIGN

1. Quantity

Three (3) Project Designation signs will be constructed and installed on the project site as directed by the Owner. It will be the responsibility of the Contractor to maintain the sign in a presentable condition at all times during construction. Maintenance will include painting and repairs as directed by the City Engineer or his appointee. The locations of the signs will be given to the Contractor by the Town of Addison at the Pre-Construction Conference.

2. Material

Sign shall be constructed of $\frac{3}{4}$ -inch thick smooth finish fir plywood (Grade A-C, exterior or better).

Sign will be securely mounted to 6" x 6" square posts. Nuts and bolts will not protrude from face of sign. Posts will be mounted to a support system that will provide adequate stabilization to ensure the sign will not fall over in heavy winds. Sand bags or other techniques may be necessary to protect sign.

3. Dimensions

Size of sign will be four feet tall and six feet wide. The height and arrangement of the lettering shall be in accordance with the attached detail.

4. Paint

Sign will be one-sided and will have a white background. Text will be black, except for the word "Addison!" which will be a blue color approved by the City Engineer. The paint will be an outdoor paint and will be maintained throughout the project in proper order. The quality of the paint, painting, and lettering on the signs shall be approved by the City Engineer or his appointee.

5. Payment

Project Signs will be a separate pay item. This will include all labor, equipment, tools, and incidentals necessary to complete and install the work.

The Town of *Addison!*

**PLEASE PARDON THE TEMPORARY
INCONVENIENCE DURING THIS PROJECT**

**BELT LINE ROAD UNDERGROUND
ELECTRICAL – PHASE 1**

CONTRACTOR: _____

ESTIMATED COMPLETION DATE: XXX

AN ADDISON PROJECT

FOR MORE INFORMATION, PLEASE CALL (972) 450-2871

SECTION TS

TECHNICAL SPECIFICATIONS

00-45-16	STATEMENT OF EXPERIENCE
07 92 13	ELASTOMERIC JOINT SEALANTS
31 23 00	LANDSCAPE EXCAVATION AND FILL
32 01 90	90 DAY ESTABLISHMENT PLANTING
32 01 92	LANDSCAPE MAINTENANCE (1 YEAR)
32 14 16	BRICK UNIT PAVING
32 80 00	TOWN OF ADDISON LANDSCAPE IRRIGATION
32 91 19	LANDSCAPE GRADING
32 92 19	SEEDING
32 92 23	SODDING
32 93 00	LANDSCAPE PLANTING
DDS-4 UG	ONCOR SPECIFICATIONS FOR ELECTRICAL UNDERGROUND DISTRIBUTION SYSTEMS
361-001	FULL DEPTH REPAIR OF CONCRETE PAVEMENT
3001	ULTRA THIN BONDED HOT MIX WEARING COURSE
3001	UTBHMWC – AGGREGATE SOURCE AND TYPE

Other guidelines and Requirements

ONCOR -	GUIDELINES FOR USE OF COMPANY PROPERTY BY OTHERS
Addison -	WATER SYSTEM REQUIREMENTS
Addison -	WASTEWATER SYSTEM REQUIREMENTS
Addison -	TRAFFIC SIGNAL REQUIREMENTS

00 45 16 STATEMENT OF EXPERIENCE

REQUIREMENT TO PROVIDE A STATEMENT OF EXPERIENCE

- 1.01 To be considered a responsive Bidder, the three lowest Bidders must complete and submit the Statement of Experience within 5 days after the date Bids are due to demonstrate the Bidders' responsibility and ability to meet the minimum requirements complete the Work. Failure to submit the required information in the Statement of Experience may result in the Owner considering the Bid non-responsive and result in rejection of the Bid by the Owner. The Bid Security of the Bidder will be forfeited if Bidder fails to deliver the Statement of Experience in an attempt to be released from its Bid. Bidders may be required to provide supplemental information if requested by the Owner to clarify, enhance or supplement the information provided in the Statement of Experience.
- 1.02 Bidders must provide the information requested in this Statement of Experience using the forms attached to this Section. A copy of these forms can be provided in Microsoft Word to assist with the preparation of the Statement of Experience. Information in these forms must be provided completely and in detail. Information that cannot be totally incorporated in the form may be included in an attachment to the form. The attachment must include only the information that responds to the question or item number to which the attachment information applies.

EXPERIENCE REQUIREMENTS

- 1.03 The Bidder agrees that, in addition to determining the apparent low Bid, the Owner will consider the responsiveness of the Bids and the responsibility of the Bidders in awarding a Contract for this Project. Information that indicates the Bidder or a Subcontractor is not responsible or that might negatively impact a Bidder's ability to complete the Work within the Contract Time and for the Contract Price may result in the Owner rejecting the Bid.
- 1.04 If none of the three apparent low Bidders are deemed responsible, the Owner may notify the next apparent low Bidders in order, who will then be required to submit the Statement of Experience for review, until a Contract is awarded or all Bids have been rejected.
- 1.05 The Bidder is responsible for the accuracy and completeness of all of the information provided by the Bidder or a proposed Subcontractor in response to this Statement of Experience.
- 1.06 Provide general information about the organization as required in Table 1. Describe the organizational structure of the Bidder's organization as it relates to this Project in Table 2.
- 1.07 Provide information on the experience of proposed key personnel.
 - A. Provide information on the key personnel that will be actively working on this Project in Tables 3. Key personnel include the Project Manager, Project Superintendent, Safety Manager, and Quality Control Manager. If key personnel are to fulfill more than one of the roles listed above, provide a written narrative describing how much time will be devoted to each function, their qualifications to fulfill each role, and the percentage of their time that will be devoted to each role. If the individual is not to be devoted solely

to this Project, indicate how that individual's time is to be divided between this Project and other assignments.

- B. The Bidder may provide information on an alternate individual if the Bidder is not able to commit to one individual for the Project at the time the Bid is submitted. Qualifications of these individuals will be considered in determining whether the experience of the Bidder meets the minimum requirements. The Bidder must provide the services of the proposed key personnel for the life of the Project as a condition of qualification. Failure to provide the proposed Key Personnel may result in the disqualification of the Bidder and may void the award of the Contract.
- C. Provide biographical information for each primary and alternate candidate as an attachment that includes: technical experience, managerial experience, education and formal training, and a work history which describes project experience, including the roles and responsibilities for each assignment. Additional information demonstrating experience that meets the minimum requirements in this Statement of Experience should also be included. Bidders are to include a list of the current project assignments for each of the individuals proposed, the anticipated completion date for this assignment, and the percentage of the time they will have available to devote to this Project to demonstrate their availability for this project.
- D. The Project Manager and Project Superintendent must have at least 5 years' recent and successful experience in the management and oversight of projects of a similar size and complexity to this Project. This experience must include scheduling of manpower and materials, safety, coordination of Subcontractors, experience with the submittal process, Federal and State wage rate requirements, and contract close-out procedures. The Project Superintendent is to be present at the Site at all times that Work is being performed.

1.08 Provide information on the project experience and past performance of the organization and Key Personnel.

- A. Provide a list of projects currently under construction and projects completed by the Bidder in the last 5 years. Highlight the project information that demonstrates the experience of Bidder with similar projects and the experience of proposed Key Personnel. Experience must include the satisfactory completion of at least three similar projects within the last 5 years for the Bidder's organization and for proposed Key Personnel that are equal to or greater in size and magnitude than the current Project. Contractor must demonstrate successful experience for duct bank construction directly related with work for power and communication utilities such as ONCOR, AT&T, TWC, etc. and with similar conditions for work on arterials with high volume traffic.
- B. In determining the responsibility of the Bidder, the Owner will consider the Bidder's past projects and any substandard quality of workmanship on completed projects. The Owner will consider whether the Bidder's past project experience shows substandard quality of workmanship, issues related to a substandard appearance of the completed work, the amount of warranty or rework required, problems with durability and maintainability of the completed project, and problems with the lack of quality of documentation provided. In addition to the work produced, the Owner may consider

issues related to the quality of construction practices, responsiveness to the owner's needs during construction, an inability to work in the spirit of partnering, and any non-responsiveness of the Bidder to make warranty corrections. Information to make this determination will come from Owner's interviews with references provided for this project. By listing reference contact information in this Statement of Experience, Bidder indicates its approval for contact the individuals listed as a reference.

- 1.09 The Owner will consider any percentages in excess of 15 percent of change orders for projects as an indicator of ability to complete Projects within the Contract Price. Provide a tabulation of budget performance on all projects completed by the Bidder within the last 5 years on Table 8 to demonstrate the ability of the Bidder to complete projects for the Contract Price. Lines may be added beneath project change order breakdowns to add explanatory comments.
- 1.10 Provide information to demonstrate the ability of the Bidder to complete projects on time. Bidders are to provide a tabulation of all projects completed by the Organization within the last 5 years on Table 9 to demonstrate performance in completing projects on time. Comments may be added to the tabulations to indicate the reasons for amending completion dates.

STATEMENT OF EXPERIENCE REQUIREMENTS

- 1.11 Provide one printed copy of the Statement of Experience.
- 1.12 Provide a digital copy of the Statement of Experience in Portable Document Format (PDF) on a CD, portable drive, or other digital recording device. This digital copy is to include all information required to evaluate the Bid and should match the content of the printed copy of the Bid. When creating the digital copy:
 - A. Create PDF documents from native format files.
 - B. Rotate pages so that the top of the document appears at the top of the file when opened in PDF viewing software.
 - C. Submit PDF documents with adequate resolution to allow documents to be printed in a format equivalent to the original documents. Documents are to be scalable to allow printing on standard 8-1/2 x 11.
 - D. Submit color PDF documents if color is used in the printed version of the documents.

Table 1 – Organization Information

Organization doing business			
Business Address of Principal Office			
Telephone		Website	
Form of Business (check one)		<input type="checkbox"/> Corporation <input type="checkbox"/> Partnership <input type="checkbox"/> Individual	
If a Corporation			
State of Incorporation		Date of	
Chief Executive Officer's		President's Name	
Vice President's Name(s)			
Secretary's Name		Treasurer's Name	
If a Partnership			
Date of		Form of Partnership: <input type="checkbox"/> General <input type="checkbox"/> Limited	
If an Individual			
Name			
Ownership of Organization			
List of companies, firms, or organizations that own any part of the organization.			
Names of Companies, Firms, or Organizations			Percent
Organization History			
List of names that this organization currently, has, or anticipates operating under including the names of related companies presently doing business.			
Names of Organizations		From Date	To Date
Indicators of Organization Size			
Average number of current full-time employees			
Average estimate of revenue for the current year			

Table 1 – Organization Information

Surety	
Name of Surety	
Surety is a corporation organized and existing under the laws of the state of	
Is surety authorized to provide surety bonds in the State of Texas?	<input type="checkbox"/> Yes <input type="checkbox"/> No
Is surety listed in “Companies Holding Certificates of Authority as Acceptable Sureties on Federal Bonds and as Acceptable Reinsuring Companies” as published in Circular 570 (amended) by the Financial Management Service, Surety Bond Branch, U.S. Department of the Treasury?	<input type="checkbox"/> Yes <input type="checkbox"/> No
Mailing Address (principal place of business)	
Physical Address(principal place of business)	
Telephone (Main)	
Telephone (for Notice of Claim)	
Local Agent for Surety	
Address for Local Agent	
Telephone for Local Agent	
Insurance	
Name of Insurance Provider	
Provider is a corporation organized and existing under the laws of the state of	
Is Provider licensed or authorized to issue insurance policies in the State of Texas?	<input type="checkbox"/> Yes <input type="checkbox"/> No
Does Provider have an A.M. Best Rating of A-VIII or Better?	<input type="checkbox"/> Yes <input type="checkbox"/> No
Mailing Address (principal place of business)	
Physical Address(principal place of business)	
Telephone (Main)	
Telephone (for Notice of Claim)	
Local Agent for Provider	
Address for Local Agent	
Telephone for Local Agent	
Financial Summary Information	
Date of Bidder's most current financial statement	
Date of Bidder's most current audited financial statement	
Financial indicators from the most current financial statement:	
Bidder's Current Ratio (Current Assets / Current Liabilities)	
Bidder's Quick Ratio ((Cash and Cash Equivalents + Accounts Receivable + Short Term Investments) / Current Liabilities))	

Table 1 – Organization Information

Organization doing business										
Previous History										
List projects that have been completed over the last 5 years. If more than 5 projects, list only the most recent.										
Project Name										Year
1										
2										
3										
4										
5										
Construction Site Safety Experience										
Provide Bidders Experience Modification Ratio (EMR) History for the last 3 years. Provide documentation of the EMR.										
Year		EMR		Year		EMR		Year		EMR
Previous Bidding and Construction Experience										
Has Bidder or a predecessor organization ever been disqualification as a bidder within the last 5 years? List Projects below and provide full details in a separate attachment if yes.										
Has Bidder or a predecessor organization been released from a bid or proposal in the past five years? List Projects below and provide full details in a separate attachment if yes.										
Has Bidder or a predecessor organization ever defaulted on a project or failed to complete any work awarded to it? List Projects below and provide full details in a separate attachment if yes.										
Has Bidder or a predecessor organization been involved in claims or litigation involving project owners within the last 5 years? List Projects below and provide full details in a separate										
Have liens or claims for outstanding unpaid invoices been filed against the Bidder for services or materials on any projects begun within the preceding 2 years. Specify the name and address of the party holding the lien or making the claim, the amount and basis for the lien or claim, and an explanation of why the lien has not been released or that the claim has not been paid if yes.										

Table 2 – Project Information

Organization doing business as:										
Proposed Project Organization										
Provide a brief description of the organizational structure proposed for this project indicating the names and functional roles of proposed key personnel and alternates.										
Division of work between Bidder and Proposed Subcontractor and Suppliers										
Provide a list of Work to be self-performed by the Bidder and the Work contracted to Subcontractors and Suppliers for more than 25 percent of the Work (based on estimated subcontract or purchase order amounts and the Contract Price).										
Description of Work					Name of Entity Performing the Work			Estimated Percentage of Contract Price		
Subcontractor Construction Site Safety Experience										
Provide Experience Modification Ratio (EMR) History for the last 3 years for Subcontractors that will provide Work valued at 25% or more of the Contract Price. Provide documentation of the EMR.										
Subcontractor										
Year		EMR		Year		EMR		Year		EMR
Subcontractor										
Year		EMR		Year		EMR		Year		EMR

Table 3 – Proposed Key Personnel

Organization doing business			
Primary Project Manager			
Name of individual			
Years of experience as Project Manager			
Years of experience with this organization			
Number of similar projects as Project			
Number of similar projects in other			
Current Project Assignments			
Name of Assignment		Percent of Time Used for this Project	Estimated Project Completion Date
Reference Contact Information			
Name		Name	
Title/Position		Title/Position	
Organization		Organization	
Telephone		Telephone	
Email		Email	
Project		Project	
Role on		Role on	
Proposed Superintendent			
Name of individual			
Years of experience as Project Manager			
Years of experience with this organization			
Number of similar projects as Project			
Number of similar projects in other			
Current Project Assignments			
Name of Assignment		Percent of Time Used for this Project	Estimated Project Completion Date
Reference Contact Information			
Name		Name	
Title/Position		Title/Position	
Organization		Organization	
Telephone		Telephone	
Email		Email	
Project		Project	
Role		Role	

Table 3. Proposed Key Personnel (continued)

Organization doing business			
Proposed Project Safety Manager			
Name of individual			
Years of experience as Project			
Years of experience with this organization			
Number of similar projects as			
Number of similar projects in other			
Current Project Assignments			
Name of Assignment		Percent of Time Used for this Project	Estimated Project Completion Date
Reference Contact Information			
Name		Name	
Title/Position		Title/Position	
Organization		Organization	
Telephone		Telephone	
Email		Email	
Project		Project	
Role on		Role on	
Proposed Project Quality Control Manager			
Name of individual			
Years of experience as Project			
Years of experience with this organization			
Number of similar projects as			
Number of similar projects in other			
Current Project Assignments			
Name of Assignment		Percent of Time Used for this Project	Estimated Project Completion Date
Reference Contact Information			
Name		Name	
Title/Position		Title/Position	
Organization		Organization	
Telephone		Telephone	
Email		Email	
Project		Project	
Role		Role	

CERTIFICATION

By submitting this Statement of Experience and related information; Bidder certifies that it has read this Statement of Experience and that Bidder's responses are true and correct and contain no material misrepresentations; and that the individual signing below is authorized to make this certification on behalf of the Bidder's organization. The individual signing this certification shall attach evidence of individual's authority to bind the organization to an agreement.

Bidder: _____
(typed or printed)

By: _____
(individual's signature)

Name: _____
(typed or printed)

Title: _____
(typed or printed)

Designated Representative:

Name: _____

Title: _____

Address: _____

Telephone No.: _____ Email: _____

END OF SECTION

SECTION 07 92 13

ELASTOMERIC JOINT SEALANTS

PART 1 GENERAL

1.1 SUMMARY

A. Section Includes:

1. Joint backup materials.
2. Joint sealers.

B. Related Sections:

1. Division 01: Administrative, procedural, and temporary work requirements.
2. Section 32 13 13 – Portland Cement Concrete Paving

1.2 REFERENCES

A. ASTM International (ASTM) (www.astm.org):

1. C804 - Standard Practice for Use of Solvent-Release Type Sealants.
2. C920 - Standard Specification for Elastomeric Joint Sealants.
3. C1330 - Standard Specification for Cylindrical Sealant Backing for Use with Cold Liquid Applied Sealants.

1.3 SUBMITTALS

A. Submittals for Review:

1. Product Data: Indicate sealers, primers, backup materials, bond breakers, and accessories proposed for use.
2. Samples:
 - a. 1/2 x 1/2 x 3 inch long joint sealer samples showing available colors.
 - b. 6 inch long joint backup material samples.

1.4 PROJECT CONDITIONS

- A. Do not apply sealers at temperatures below 40 degrees F unless approved by sealer manufacturer.

PART 2 PRODUCTS

2.1 MANUFACTURERS

A. Acceptable Manufacturers:

1. BASF Building Systems. (www.chemrex.com)
2. Dow Corning Corp. (www.dowcorning.com)
3. GE Silicones. (www.gesealants.com)

4. Pecora Corp. (www.pecora.com)
5. Sika Corp. (www.sikausa.com)
6. Tremco, Inc.

B. Substitutions: Under provisions of Division 01.

2.2 MATERIALS

A. Joint Sealer Type 1:

1. ASTM C920, Grade P, multiple component polyurethane type, self-leveling and slope grades.
2. Movement capability: Plus or minus 50 percent.
3. Color: To be selected from manufacturer's full color range.
4. Uses: Joints in horizontal surfaces subject to pedestrian or vehicular traffic.

B. Joint Sealer Type 2:

1. ASTM C920, Grade NS, single component silicone type, non sag.
2. Movement capability: Plus or minus 50 percent.
3. Color: To be selected from manufacturer's full color range.
4. Uses: Joints in vertical surfaces.

2.3 ACCESSORIES

A. Primers, Bondbreakers, and Solvents: As recommended by sealer manufacturer.

B. Joint Backing:

1. ASTM C1330, closed cell polyethylene foam, preformed round joint filler, non absorbing, non staining, resilient, compatible with sealer and primer, recommended by sealer manufacturer for each sealer type.
2. Size: Minimum 1.25 times joint width.

2.4 MIXES

A. Mix multiple component sealers in accordance with manufacturer's instructions.

1. Mix with mechanical mixer; prevent air entrainment and overheating.
2. Continue mixing until color is uniform.

PART 3 EXECUTION

3.1 PREPARATION

A. Remove loose and foreign matter that could impair adhesion. If surface has been subject to chemical contamination, contact sealer manufacturer for recommendation.

B. Clean and prime joints in accordance with manufacturer's instructions.

- C. Protect adjacent surfaces with masking tape or protective coverings.
- D. Sealer Dimensions:
 - 1. Minimum joint size: 1/4 x 1/4 inch.
 - 2. Joints 1/4 to 1/2 inch wide: Depth equal to width.
 - 3. Joints over 1/2 inch wide: Depth equal to one half of width.

3.2 APPLICATION

- A. Apply products in accordance with manufacturer's instructions.
- B. Perform installation in accordance with ASTM C804 for solvent release and ASTM C790 for latex base sealers.
- C. Install joint backing to maintain required sealer dimensions. Compress backing approximately 25 percent without puncturing skin. Do not twist or stretch.
- D. Use bondbreaker tape where joint backing is not installed.
- E. Fill joints full without air pockets, embedded materials, ridges, and sags.
- F. Tool sealer to smooth profile.
- G. Apply sealer within recommended temperature range. Consult manufacturer when sealer cannot be applied within these temperature ranges.

3.3 CLEANING

- A. Remove masking tape and protective coverings after sealer has cured.
- B. Clean adjacent surfaces.

END OF SECTION

SECTION 31 23 00

LANDSCAPE EXCAVATION AND FILL

PART 1 - GENERAL

1.1 SCOPE

- A. Perform all work required to complete the project as indicated by the Contract Documents, and furnish all supplementary items necessary for the completion of all work specified in this Section.
- B. The work included in this Section shall include furnishing all labor, tools, materials and incidentals required to complete the work; excavate and fill to the lines, elevations and limits shown on the drawings for all pavements, buildings, landscaped areas, etc. as indicated below and cleaning up. The landscaped areas shall be graded to an elevation 6 inches below finished grade allowing for topsoil placement.

1.2 RELATED WORK SPECIFIED ELSEWHERE

- A. Section 31 91 19 – Landscape Grading

1.3 QUALITY ASSURANCE

A. Codes and Standards

- 1. Perform excavation work in compliance with applicable requirements of governing authorities having jurisdiction. The Contractor shall have a trench safety plan prepared by a registered professional engineer for all excavations in excess of 5 feet deep.

B. Testing and Inspection Service

- 1. The Contractor will engage a soil testing and inspection service for quality control testing during earthwork operations to inspect and test all soil materials proposed for use in all excavation and fill operations.

1.4 JOB CONDITIONS

A. Existing Utilities

- 1. It shall be the Contractor's responsibility to verify the location (horizontal and vertical depth) of all utilities prior to beginning earthwork operations. If utilities are to remain in place, provide protection from damage during construction operations.
- 2. Should uncharted or incorrectly charted piping or other utilities be encountered during excavation, consult Owner immediately for directions as to how to proceed. Cooperate with Owner, public and private utility companies in keeping services and facilities in operation. Repair damaged utilities to satisfaction of utility Owner.
- 3. Do not interrupt existing utilities serving facilities occupied and used by Owner, except when permitted in writing by Owner and then only after temporary utility services have been provided.

- B. Use of Explosives
 - 1. The use of explosives is not permitted.
- C. Protection of Persons and Property
 - 1. Barricade open excavations occurring as part of this work and post with warning lights. Provide traffic control as required by the City and as required to protect the public.
 - 2. Protect structures, utilities, sidewalks, pavements, and other facilities from damages caused by settlement, lateral movement, undermining, washout and other hazards created by excavation operations.

PART 2 - PRODUCTS

2.1 SOIL MATERIALS

- A. Fill Material:
 - 1. Onsite excavated material free from trash, vegetation, rocks and lumps of earth larger than 4 inches in diameter or other objectionable material. Imported fill, if required, shall also be clean and have a plasticity index less than 35.
- B. Select Material:
 - 1. Uniformly blended clayey sand (greater than 50 percent passing the No. 200 sieve) with a P.I. between 6 and 15 and L.L. of 35 or less.
- C. Free draining aggregate (drainage behind walls, under ponds and in landscape beds):
 - 1. Free draining river run gravel with no fines or hard durable crushed limestone where 100% passes a 1-inch sieve and 100% is retained on a No. 8 Sieve.

PART 3 - EXECUTION

3.1 INSPECTION

- A. Examine the areas and conditions under which earthwork and site grading operations are to be performed. After excavation to subgrade, proofroll with a heavy pneumatic tired roller, loaded dump truck or similar equipment weighing approximately 25 tons or greater to help compact pockets of loose soil and expose additional areas of weak, soft or wet soils in the presence of the Owner's Representative. Do not proceed with the work until unsatisfactory conditions have been corrected in an acceptable manner.

3.2 EXCAVATION

- A. The Contractor shall excavate to the lines and elevations shown on the Drawings, as previously indicated herein, regardless of the type, condition, or moisture content of the material encountered. Conduct excavation operations to provide positive drainage, at Contractor's expense, at all times during construction. If positive drainage cannot be maintained, Contractor shall keep standing water out of all excavations with adequate dewatering equipment.
- B. All areas shall be cut accurately to the indicated grades. Care shall be taken to prevent excavation below the grades indicated and any bottoms or slopes that have been undercut shall be backfilled with approved materials and compacted to the required fill density.

- C Excavation required for rough grading shall be finished within a tolerance of 0.10 foot above or below the rough grade and in no case shall depressions be left that will not completely drain.
- D. Excavation in the inlet (harbor area of the project) shall include all wet soil (above optimum moisture +4%) and shall continue to a depth where soil capable of being properly compacted is encountered.

3.3 BUILDING SUBGRADE

- A. Follow recommendations in geotechnical report and on the structural drawings.

3.4 FILLING

- A. Remove all wet soil, vegetation, organic materials and debris prior to placing fill.
- B. Fill used below the parking and landscape areas shall be onsite soils encountered in the excavation or imported fill except grass, weeds, roots, vegetation and similar materials. The largest rock, particle or clod shall be less than 4 inches in diameter prior to compaction.
- C. Care should be taken that utility cuts are not left open for extended periods and that cuts are properly backfilled. A positive cut-off of compacted clay at the building line shall be used to help prevent water from migrating in the utility trench.
- D. Before fill is placed under pavement or if subgrade is in an excavation, subgrade soils shall be scarified to a depth of 6" and recompact between 95 and 100 percent of maximum dry density per ASTM D698 at a moisture content from -1 to +3 percent above optimum moisture content.
- E. Fill below all pavement and landscaped areas shall be placed in 6 to 8 inch loose lifts and compacted to a minimum dry density of 95 percent to 100 percent of the standard proctor density (ASTM D698) under pavement and 90 percent elsewhere. The moisture content shall be between 0 and +4 percent above optimum.

In cases where either mass fills or utility lines are more than 10 ft. deep, the fill/backfill below 10 ft should be compacted to at least 100 percent of standard Proctor maximum dry density (ASTM D-698) and with 2 percentage points of the material's optimum moisture content. The portion of the fill/backfill shallower than 10 ft should be compacted as outlined above.

If fill is to be placed on existing slopes (natural or constructed) steeper than six horizontal to one vertical (6:1), the fill materials should be benched into the existing slopes in such a manner as to provide a minimum bench-key width of five (5) feet.

- F. Compaction shall be obtained by use of sheeps foot rollers, rubber-tired rollers, or other approved equipment capable of obtaining the required density. In the event the embankment material is too wet or too dry for adequate compaction, the Contractor shall add moisture or dry the material as required to the extent necessary to obtain the required density.

3.5 FLATWORK SUBGRADE

- 1. Construct subgrades for paved areas to conform to the grades, lines and cross sections shown on the Drawings, of uniform density.
- 2. After the pavement subgrades have been shaped and compacted, bring the surface to a firm, unyielding surface by rolling the entire area with an approved vibratory roller. Compact all areas inaccessible to the roller with hand tampers weighing not less than 50 pounds, and with face area not more than 100-square-inches. Unless the material at the time of the rolling

contains sufficient moisture to insure proper compaction, add water as directed before compacting. Allow the material containing excess moisture, to dry to the proper consistency and moisture content before being compacted.

3.6 MOISTURE CONTROL

- A. Where soil material must be moisture conditioned before compaction, uniformly apply required amount of water to surface of soil material in such manner as to prevent free water appearing on surface during, or subsequent to, compaction operations.
- B. Remove and replace, or scarify and air dry soil material that is too wet to permit compaction to specified percentage of maximum density.
- C. Soil material that has been removed because it is too wet to permit compaction may be stockpiled or spread on surface where directed by Owner's Representative and permitted to dry. Assist drying by discing, harrowing or pulverizing, until moisture-density relation tests fall within the herein-specified range.

3.7 FIELD QUALITY CONTROL

A. Quality Control Testing During Construction

- 1. Testing laboratory services shall be in accordance with the Special Provisions.
- 2. Allow testing service to inspect and approve subgrades and fill layers before further construction work is performed. In the building areas there will be at least 1 density test per 2500 square feet per lift with a minimum of 3. In the pavement areas there will be at least 1 density test per 5000 square feet per lift with a minimum of 3.
- 3. If, in the opinion of the Owner, based on testing service and inspection, the subgrade or fills, which have been placed, are below the specified density, provide additional compaction and testing at no expense to the Owner.
- 4. The results of density tests which may be selected will be considered satisfactory when they are in each instance equal to or greater than the specified density, and if not more than 1 density test out of 5 has a value greater than 2% below the required density.

3.8 MAINTENANCE

A. Protection of Graded Areas

- 1. Protect newly graded areas from traffic and erosion. Keep free of trash and debris.
- 2. Repair and re-establish grades in settled, eroded, and rutted areas to the specified tolerances.

B. Reconditioning Compacted Areas

- 1. Where completed compacted areas are disturbed by subsequent construction operations or adverse weather, scarify the surface, reshape, and compact to the required density prior to further construction. Use hand tamping for recompaction over underground utilities.

3.8 DISPOSAL OF EXCESS AND WASTE MATERIALS

Reference Special Provisions.

END OF SECTION

SECTION 32 01 90

90 Day Establishment Planting

PART 1 GENERAL

1.1 SECTION INCLUDES

- A. Scheduling of maintenance
- B. Monitoring, adjustment and repair of sprinkler irrigation.
- C. Mowing, edging and trimming of lawn areas.
- D. Pruning and trimming of trees and shrubs.
- E. Weeding of lawn and bed areas.
- F. Application of fertilizers and pesticides.
- G. General site clean up and removal of trash.
- H. Provide long term landscape maintenance instructions.
- I. Cold Weather Maintenance of Irrigation System

1.2 RELATED SECTIONS

- A. Section 32 80 00 – Landscape Irrigation System
- B. Section 32 93 00 – Landscape Planting
- C. Section 32 01 91 – Organic Landscape Maintenance

1.3 REFERENCES

- A. ANSI Z60.1 - American Standard for Nursery Stock; 1996.
- B. ANSI A300 - American National Standard for Tree Care Operations -- Tree, Shrub and Other Woody Plant Maintenance -- Standard Practices; 1995.

1.4 QUALITY ASSURANCE

- A. Requirements of Regulatory Agencies:
 - 1. Perform all work in accordance with all applicable laws, codes, and regulations required by authorities having jurisdiction over such work.
 - 2. Provide for all inspections and permits required by Federal, State, or local authorities in furnishing, transporting, and installing of all agricultural chemicals.
 - 3. Provide monthly records of all fertilizers and pesticides used for the project.
 - 4. Perform all work within the standards set forth in the Organic Landscape Maintenance specifications (Section 32 01 91)
- B. Work Force:
 - 1. Experience: The landscape establishment firm shall have a full time foreman assigned to the job for the duration of the contract. He shall have a minimum of four years experience in landscape establishment supervision, with experience or training in turf management, entomology, pest control, soils, fertilizers and plant identification.

2. **Labor Force:** The landscape establishment firm's labor force shall be thoroughly familiar and trained in the work to be accomplished and perform the task in a competent, efficient manner acceptable to the Owner.
3. **Supervision:** The designated foreman shall directly supervise the work force at all times. Notify the Owner of all changes in supervision.
4. **Identification:** Provide proper identification at all times for landscape establishment firm's labor force. Be uniformly dressed in a manner satisfactory to the Owner.

1.5 SUBMITTALS

- A. See Section 01 33 00 - Submittal Requirements, for submittal procedures, if applicable.
- B. Prior to commencing the landscape installation, submit to Owner's Representative for approval, two (2) copies each of the following items:
 1. Proposed schedule of establishment operations.
 2. All licenses and insurances required by the Owner, City of Dallas, County of Dallas, State of Texas, or any other entity, pertaining to this work.
- C. During the landscape establishment period at monthly intervals submit to Owner's Representative two (2) copies each of the following items:
 1. Written application recommendation by a licensed pesticide applicator for any proposed weed, pest and disease control which is intended to be used where restrictions are required by the Department of Agriculture.
 2. Provide monthly records of all fertilizers and pesticides used for the project.
 3. Provide each month of the establishment period, written reports and logs as follows:
 - a. Provide monthly status report of site conditions outlined weekly.
 - b. Provide monthly status report of irrigation controller operations and adjustments required.
- D. Submit to the Owner's Representative written maintenance instructions as outlined below.

1.6 SCHEDULING

- A. Perform all establishment during hours mutually agreed upon between Owner and Contractor.
- B. Work force shall be present at the project site at least once a week, and as often as necessary, to perform specified establishment in accordance with the approved establishment schedule.

1.7 PROJECT CONDITIONS

- A. **Site Visit:** At beginning of establishment period, visit and walk the site with the Owner's Representative to clarify scope of work and understand existing project/site conditions.
- B. **Documentation of Conditions:** Document general condition of existing trees, shrubs, vines, ground covers and lawn and replace all plant materials which are damaged or dying, if any.

- C. Irrigation System: Document general condition of existing irrigation system, making sure that faulty electrical controllers, broken or inoperable sprinklers are repaired or replaced.

1.8 CONTRACTOR RESPONSIBILITIES

- A. The Contractor shall begin maintenance after any portion of the sprinkler irrigation, any plant or any lawn portion is installed. The cost of landscape maintenance until the end of the ninety (90) day establishment period will be at the expense of the Contractor.
- B. The Contractor's establishment period shall begin upon inspection and approval at Final Completion and shall be for a minimum of ninety (90) days. Should the contractor's own work prevent Final Acceptance of the site, the site shall be maintained at the Contractor's expense until Final Acceptance of the Contractor's work. The ninety-day establishment period will start only upon Final Acceptance of the Work by the Owner.
- C. Sprinkler Irrigation System: Monitor and adjust the duration and frequency of the watering schedule, adjustment of heads for coverage and elevation, repair leaks, and all other work required to maintain a complete working sprinkler irrigation system.
- D. Trees, Shrubs, Ground covers and Vines: The Contractor's responsibilities for the new planting shall consist of, but not be limited to; watering, fertilization, weeding, mulching, re-staking, adjustment of tree staking and/or guying, resetting plants to proper grades or upright position, maintenance of the tree rings, and protecting the plantings from insects and disease infestation.
- E. Lawns: The Contractor's maintenance of new lawns shall consist of weekly mowing, edging, watering, fertilization, weeding, repair of all erosion and reseeding and re-sodding as necessary to establish a full and uniform stand of the specified grasses.

1.9 PROTECTION

- A. Protect planting areas and lawns at all times against damage of all kinds for duration of maintenance period. Maintenance includes temporary protection fences, barriers and signs as required for protection. If any plants become damaged or injured, because sufficient protection was not provided, treat or replace as directed by Owner at no additional cost to the Owner.

1.10 FINAL ACCEPTANCE

- A. Work under this Section will be accepted by the Owner's Representative upon satisfactory completion of all work, including establishment, but exclusive of the required guaranteed sprinkler irrigation obligations, replacement of plant materials and lawns under the Warranty Period. Upon Final Acceptance, the Owner will assume responsibility for maintenance of the work. This assumption will not relieve the Contractor of his warranty obligations.

1.11 WARRANTIES AND REPLACEMENTS

- A. Refer to Sections 32 80 00 Landscape Irrigation, 32 93 00 Landscape Planting

1.12 MAINTENANCE INSTRUCTIONS

- A. At the completion of work, furnish two (2) copies of written maintenance instructions to the Owner and one (1) copy to the Owner's Representative for maintenance and

care of the sprinkler irrigation system, lawns and all planting area throughout the year.

PART 2 PRODUCTS

2.1 MATERIALS

- A. All materials and equipment necessary for maintenance operations will be provided by the Contractor. The selection of materials to be used for maintenance operations will be left to the discretion of the Contractor. Any materials, and the application of those materials, must comply with all federal, state, county, city and local laws and codes. The Contractor shall use established and accepted horticultural practices. Failure to do so may result in plant replacement at the Contractor's expense.
- B. Water: Clean, potable and fresh, furnished and paid for by the Owner.
- C. Annuals/Perennials: Nursery-grown in pots, full, healthy plants just ready to bloom matching on site materials.
- D. Lawn Seed for Reseeding: Match existing lawn mix.
- E. Lawn Sod for Resodding: Match existing sodded lawn.
- F. Replacement Tree Guys, Stakes, Ties and Wires: Match existing materials on the site. Provide detail(s) in 8-1/2 in. x 11 in. format for staking which will vary from the site staking due to unusual or unknown site conditions.

2.2 REQUIRED MAINTENANCE EQUIPMENT

- A. Contractor's option, well maintained in first class condition, capable of successfully executing the work.

PART 3 EXECUTION

3.1 GENERAL

- A. Duration: Continuously maintain all landscape areas after installation, during progress of work, and for a period of no less than ninety (90) days after Final Acceptance of all planting work.
- B. Protection:
 - 1. Protect all planting areas from damage from beginning of work until the end of the ninety-day establishment period.
 - 2. Establishment includes temporary protection fences, barriers and signs as required for protection.
- C. Replacements:
 - 1. Immediately replace all plants that become damaged or injured, as directed by the Owner's Representative at no additional cost to the Owner.
 - 2. Replacement plants shall be of the size, condition and variety originally installed.

3.2 DEBRIS AND LITTER REMOVAL

- A. It shall be the responsibility of the Contractor to inspect the site weekly and remove all litter and debris accumulations.

3.3 SUPPLEMENTAL WATERING

- A. It shall be the responsibility of the Contractor to assure that the correct watering of plant materials is being accomplished through the use of the irrigation system, hand-watering, 'gator' bags, water truck, etc.
- B. Contractor shall monitor settings of automatic sprinkler controls and make necessary adjustments according to climatic changes.
- C. Contractor shall not be responsible for supplemental watering areas that do not have irrigation systems, unless required by the Contract.
- D. Contractor shall be responsible for damages to irrigation system caused by mowing and other maintenance operations. Such damage will be repaired immediately at the Contractor's expense.

3.4 TREES, SHRUBS AND VINES

A. General:

- 1. The Contractor shall use established and accepted horticultural practices in the care of the plant material.
- 2. Maintain originally specified depth of mulch to reduce evaporation and frequency of watering.
- 3. Check for moisture penetration throughout the root zone at least once per week.

B. Weed Control:

- 1. All materials and equipment necessary for maintenance operations will be provided by the Contractor. The selection of materials to be used for maintenance operations will be left to the discretion of the Contractor. Any materials, and the application of those materials, must comply with all federal, state, county, city and local laws and codes. The Contractor shall use established and accepted horticultural practices. Failure to do so may result in plant replacement at the Contractor's expense.
- 2. All lawn areas, tree rings and planting areas will be maintained in a healthy weed-free condition.

C. Pruning:

- 1. Remove any broken, damaged, or crossing branches not removed at installation.
- 2. No stripping of lower branches ('raising' or 'skirting') or cutting back ('heading' or 'topping') of trees will be permitted. The Contractor shall use established and accepted horticultural practices in the care of the plant material.
- 3. Prune damaged trees or those that constitute health or safety hazards at any time of year as required.
- 4. Do not use pruning paint or pruning compounds on pruning cuts. Allow the cuts to callous naturally.
- 5. Do not prune or clip shrubs into balled or boxed forms unless specifically called for by design.

3.5 GROUNDCOVERS

A. Watering:

1. Check for moisture penetration throughout the root zone at least twice a month.
2. Water as frequently as necessary to maintain healthy growth of ground covers.

B. Weed Control:

1. All planting areas will be maintained in a healthy weed-free condition by the use of pre- and post-emergent herbicides or hand-pulling.
2. To avoid root damage to young plants, minimize weed growth and protect the chemical barrier of pre-emergent herbicides, cultivation of beds and tree wells will not be permitted.

3.6 LAWNS

A. Watering:

1. Water lawns at such frequency as weather conditions require replenishing soil moisture to 6 in. below soil surface.
2. Apply enough water to newly sodded areas to wet the soil to a depth of 2"-3" (approx. ¼ inch in clay soils). In newly seeded areas; provide only enough water to keep the soil surface moist, but not water logged. In established lawn areas, apply enough water to wet the soil to a depth of 6" (approx. ½ inch in clay soils). These application rates are suggestions only. The frequency and actual duration of watering cycles will vary according to weather, soil type, slopes, etc. The contractor will be solely responsible for providing the optimum watering schedule for the project.
3. In established areas, water during early morning hours when the wind is calmest.

B. Weed Control:

1. All lawn areas will be maintained in a healthy weed-free condition by the use of pre- and post-emergent herbicides or hand-pulling. Any materials, and the application of those materials, must comply with all federal, state, county, city and local laws and codes. The Contractor shall use established and accepted horticultural practices. Failure to do so may result in plant replacement at the Contractor's expense.
2. Provide the Owner with 48 hour notice of chemical applications. Within 48 hours of application, provide Owner with a copy of the applicator's log book showing the time, date, and type and amount of chemical used and

C. Mowing and Edging:

1. Mowing lawn/grass areas shall be accomplished with sharp, properly adjusted mowers of the correct size for the various areas
2. Mowing frequency shall be weekly. Blade heights shall be set according to the type of turf and weather conditions.
3. Trim edges with each mowing or as required for neat appearance. Edging shall be performed with a blade type mechanical edger, shovel or herbicide. String whips shall not be permitted. Remove clippings.

- D. In the event of a prolonged rainy period and a surge of leaf growth is anticipated, the mower height may be re-adjusted to prevent "scalping" or skinning of lawn on preceding cuts. At no time shall more than 1/3 of the leaf blade be removed in one mowing.
- E. Lawn Fertilizer: Applied during the establishment period at 45 days after turf installation.
 - 1. Preparation: Water areas to receive fertilizer 48 hour prior to application. Allow leaf surface to dry before fertilizer application. Do not apply fertilizer to turf wet from dew, rain or irrigation. Water lightly after application to remove fertilizer granules from leaf blades
 - 2. Application: Apply no more than ½ lb. of actual nitrogen per 1000 square feet.
 - 3. Reseeding of Lawn Areas: Match existing seed mix of adjacent areas.
 - a. Until the establishment of the turf, the Contractor will be responsible for replacing soils that have eroded onto the paved areas. Residual soils on paving will be removed and if not mingled with objectionable materials, may be re-used in eroded areas.
 - b. Immediately upon observing any lawn grass spreading into shrub or ground cover areas, the Contractor shall initiate a program of mechanical removal and maintain this program throughout the maintenance period.
 - c. Treat any lawn grass appearing in paved areas with a non-selective foliar herbicide. Do not use brush killers or soil sterilants.
 - 4. Special effort shall be given to the control of fire ants infesting the site. After control is accomplished, the ant mounds shall be removed.

3.7 ANNUALS AND PERENNIALS

- A. Care for all seasonal color and perennial beds per established and accepted horticultural practices. Failure to use proper horticultural practices may result in replacement of the plant material at the Contractor's expense.
- B. Weed Control: All planters with annuals and perennials shall be weed-free at all times.
- C. Pruning:
 - 1. Limit pruning to removal of damaged or dead twigs and foliage.
 - 2. Remove spent flowers on a weekly basis.
- D. Replacements of Annuals:
 - 1. Replace annuals when materials exhibit a "spent" condition or as directed by the Owner or Landscape Architect.
 - 2. Thoroughly cultivate soil, incorporate slow release fertilizers and rake smooth.

3.8 INSECTS, PESTS, AND DISEASE CONTROL

- A. Contractor shall be continuously alert for signs of the presence of insect or disease infestation. The Contractor shall immediately take action to control to infestation. Plant material that is damage or that dies from insect or disease infestation while under the Contractor's care shall be immediately replaced at the Contractor's expense.

- B. Application: Perform spraying for insect, pest and disease control only by licensed personnel. Spray with extreme care to avoid all hazards to any person or animals in the area or adjacent areas.

3.9 IRRIGATION SYSTEM

A. General:

1. Repair without charge to the Owners all damages to system caused by Contractor's operations. Perform all repairs within 24 hours of the damage occurring.
2. Report promptly to the Owner all accidental damage not resulting from Contractor's negligence or operations.
3. Do not run the irrigation system during periods of rain. Set and program automatic controllers for seasonal water requirements.
4. Twice a month, use a probe or other acceptable tool to check the rootball moisture of representative plants as well as the surrounding soil.

B. Cleaning and Monitoring the System:

1. Continually monitor the irrigation systems to verify that they are functioning properly as designed. Make program adjustments required by changing field conditions.
2. If applicable clean pump filter and strainer as often as necessary to keep the irrigation systems free of sand and other debris.
3. Prevent spraying on windows, building walls, (game courts) by balancing the flow control on the remote control valves and the adjustment screws on the sprinkler heads. Do not allow spray to atomize and drift.

- C. Winterization: Normally, the irrigation system should be left operational during the winter. While the frequency may be as little as one cycle per month, the landscape will need supplemental water if winter rainfall is not adequate.

Should winterization be necessary, the Contractor shall take any and all steps necessary to protect the irrigation system. It shall also be the Contractor's responsibility to take whatever steps necessary to protect the landscape and pavement from icing caused by the irrigation system.

The Contractor will re-activate the system as soon as the freezing conditions have ended.

3.10 THE 90-DAY ESTABLISHMENT PERIOD

- A. Preliminary Review: As soon as all plantings are completed per Contract Documents, hold a preliminary review to determine the condition of the work.
- B. Date of Review: Submit a written request to the Owner's Representative at least five (5) working days prior to anticipated date of review.
- C. Beginning of the 90-Day Establishment Period: The date on which the Owner's Representative issues a letter of Preliminary Acceptance to the Contractor. Generally, the date of final acceptance of the landscape.

3.11 FINAL ACCEPTANCE

- A. Acceptance:

1. Work will be accepted by the Owner's Representative upon satisfactory completion of all work, including establishment period, but exclusive of replacement of materials under the Warranty Period.
 2. Submit a written request to the Owner's Representative for review for Final Acceptance at least five (5) working days prior to the anticipated Final Review date, which is at the end of the Establishment Period.
- B. Corrective Work:
1. Work requiring corrective action or replacement in the judgment of the Owner's Representative shall be performed within ten (10) calendar days after the Final Review.
 2. Corrective work and materials replacement shall be performed in accordance with the Drawings and Specifications, and shall be made by the Contractor at no cost to the Owner.
 3. After corrective work is completed, the Contractor shall again request a Final Review for Final Acceptance as outlined above.
 4. Continue establishment of all landscaped areas until such time as all corrective measures have been completed and accepted.
- C. Conditions for Acceptance of Work at End of Establishment Period:
1. Each plant shall be alive and thriving, showing signs of growth and no signs of stress, disease, or any other weaknesses.
 2. All plants not meeting these conditions shall be replaced and a 90 Day Establishment Period commenced for such plants.
- D. Owner's Acceptance of the Work: Upon completion of the ninety (90) establishment period and installation of all warranty replacements, the Owner will assume responsibility for maintenance of the work.

3.12 CLEAN-UP

- A. All areas shall be kept neat and orderly at all times. Debris from maintenance operations shall be gathered and shall not be allowed to remain in place in excess of two (2) hours. Remove all such debris from the site at the end of each day.

END OF SECTION

SECTION 32 01 92

LANDSCAPE MAINTENANCE (1 YEAR)

PART 1 GENERAL

1.1 SECTION INCLUDES

- A. Scheduling of maintenance
- B. Monitoring, adjustment and minor repair of sprinkler irrigation.
- C. Mowing, edging and trimming of lawn areas.
- D. Pruning and trimming of trees and shrubs.
- E. Weeding of mulched areas.
- F. Application of fertilizers, insecticides, and herbicides.
- G. General site clean up; removal of trash and products of maintenance.
- H. Provide long-term landscape maintenance instructions.
- I. Winterization of Irrigation System (if applicable)

1.2 RELATED SECTIONS

- A. Section 32 80 00 - Irrigation System
- B. Section 32 92 19 – Seeding
- C. Section 32 92 23 - Sodding
- D. Section 32 93 00 - Landscape Planting

1.3 REFERENCES

- A. ANSI Z60.1 - American Standard for Nursery Stock; 1996.
- B. ANSI A300 - American National Standard for Tree Care Operations -- Tree, Shrub and Other Woody Plant Maintenance -- Standard Practices; 1995.

1.4 QUALITY ASSURANCE

- A. Requirements of Regulatory Agencies:
 - 1. Perform all work in accordance with all applicable laws, codes, and regulations required by authorities having jurisdiction over such work.
 - 2. Provide for all inspections and permits required by Federal, State, or local authorities in furnishing, transporting, and installing of all agricultural chemicals.
 - 3. Provide monthly records of all fertilizers and pesticides used for the project.
- B. Work Force:
 - 1. Experience: The landscape establishment firm shall have a full time foreman assigned to the job for the duration of the contract. He shall have a minimum of four years experience in landscape establishment supervision, with experience or training in turf management, entomology, pest control, soils, fertilizers and plant identification.
 - 2. Labor Force: The landscape establishment firm's labor force shall be thoroughly familiar and trained in the work to be accomplished and perform the task in a competent, efficient

manner acceptable to the Owner.

3. **Supervision:** The designated foreman shall directly supervise the work force at all times. Notify Owner of all changes in supervision.
4. **Identification:** Provide proper identification at all times for landscape establishment firm's labor force. Be uniformly dressed in a manner satisfactory to the Owner.

1.5 SUBMITTALS

- A. Prior to commencing the landscape installation, submit to Owner's Representative for approval, two (2) copies each of the following items:
 1. Proposed schedule of maintenance operations.
 2. All licenses and insurances required by the owner, town of Addison, or any other entity, pertaining to this work.
- B. During the landscape maintenance period at monthly intervals submit to Owner's Representative two (2) copies each of the following items:
 1. Written application recommendation by a licensed agricultural pest control advisor for any proposed weed, pest and disease control which is intended to be used where restrictions are required by the Department of Agriculture.
 2. Provide weekly records of all fertilizers, herbicides, insecticides and disease control methods used for the project
 3. Provide each month of the maintenance period, written reports and logs as follows:
 - a. Provide monthly status report of site conditions outlined weekly.
 - b. Provide monthly status report of irrigation controller operations and adjustments required.
- C. Submit to Owner's Representative written maintenance instructions as outlined below.

1.6 SCHEDULING

- A. Perform all maintenance during hours mutually agreed upon between Owner and Contractor.
- B. Work force shall be present at the project site at least twice a week and as often as necessary to perform specified maintenance in accordance with the approved maintenance schedule.

1.7 PROJECT CONDITIONS

- A. **Site Visit:** Prior to the beginning of the 1-year maintenance period, visit and walk the site with the Owner's representative to clarify scope of work and understand existing project/site conditions.
- B. **Documentation of Conditions:** Document general condition of existing trees, shrubs, vines, ground covers and lawn recording all plant materials which are damaged or dying, if any.
- C. **Irrigation System:** Document general condition of existing irrigation system, making sure that faulty electrical controllers, broken or inoperable sprinklers are repaired or replaced

1.8 CONTRACTOR RESPONSIBILITIES

- A. The Contractor shall begin one year maintenance after receiving written notice to proceed from the Owner (following completion of 90 day establishment period, reference Section 32 01 90). At this time, the contractor will be responsible for any

and all existing conditions in regard to the landscape planting and irrigation system.

- B. **Sprinkler Irrigation System:** Monitor and adjust The Contractor's maintenance of the sprinkler irrigation system shall consist of monitoring and adjustment of the duration and frequency of the watering schedule, adjustment of heads for coverage and elevation, repair leaks in both mains and lateral lines, and all other work required to maintain a complete working sprinkler irrigation system.
- D. **Trees, Shrubs, Ground covers and Vines:** The Contractor's responsibilities for maintenance of the new planting shall consist of, but not be limited to; watering, fertilization, weeding, mulching, re-staking, adjustment of tree staking and/or guying, resetting plants to proper grades or upright position, maintenance of the tree rings, and protecting the plantings from insects and disease infestation.
- E. **Lawns:** The Contractor's maintenance of new lawns shall consist of, but not be limited to, weekly mowing, edging, watering, fertilization, weeding, repair of all erosion and reseeding and re-sodding as necessary to maintain a full, uniform and weed-free stand of the specified grasses.

1.9 PROTECTION

- A. **Protect planting areas and lawns at all times against damage of all kinds for duration of maintenance period.** Maintenance includes temporary protection fences, barriers and signs as required for protection. If any plants become damaged or injured, because sufficient protection was not provided, treat or replace as directed by Owner at no additional cost to Owner.

1.10 WARRANTIES AND REPLACEMENTS

- A. **Plant material that dies under the care of the contractor shall be replaced by material of equal size and quality at no cost to the Owner.** Damage to the site and/or irrigation system resulting from maintenance activities shall be repaired at no cost to the Owner.

PART 2 PRODUCTS

2.1 MATERIALS

- A. **General:** All materials and equipment necessary for maintenance operations will be provided by the Contractor. The selection of materials to be used for maintenance operations will be left to the discretion of the Contractor. Any materials, and the application of those materials, must comply with all federal, state, county, city and local laws and codes. The Contractor shall use established and accepted horticultural practices. Failure to do so may result in plant replacement at the Contractor's expense.
- B. **Materials required for replacement of installed items shall match those already in use.**
- C. **Samples of all materials not specified under other Sections of these Specifications shall be submitted for review by Owner's Representative prior to use.**
- D. **Water:** Clean, potable and fresh, furnished and paid for by the Owner.
- E. **Annuals/Perennials:** Nursery-grown in pots, full, healthy plants just ready to bloom matching on site materials.
- F. **Lawn Seed for Reseeding:** Match existing lawn mix.
- G. **Lawn Sod for Re-sodding:** Match existing sodded lawn.
- H. **Replacement Tree Guys, Stakes, Ties and Wires:** Match existing materials on the site. Provide detail(s) in 8-1/2 in. x 11 in. format for staking which will vary from the site staking due to unusual or unknown site conditions.

2.2 REQUIRED MAINTENANCE EQUIPMENT

- A. Contractor's option, well maintained in first class condition, capable of successfully executing the work within the agreed time allotment. Deflectors or guards shall be in place and in good working order at all times.

PART 3 EXECUTIONS

3.1 GENERAL

- A. **Duration:** Continuously maintain all landscape areas after installation, during progress of work, and for a period of no less than one year after 90 day maintenance period.
- B. **Protection:**
 - 1. Protect all newly planted areas from damage.
 - 2. Establishment of newly installed material includes temporary protection fences, barriers and signs as required for protection.
- C. **Replacements:**
 - 1. Immediately treat or replace all plants that become damaged or injured, as directed by Owner's Representative at no additional cost to Owner.
 - 2. Replacement plants shall be of a size, condition and variety acceptable to Owner's Representative.

3.2 DEBRIS AND LITTER REMOVAL

- A. It shall be the responsibility of the Contractor to inspect the site twice weekly and remove all litter and debris accumulations in planting and paved areas.

3.3 SUPPLEMENTAL WATERING

- A. It shall be the responsibility of the Contractor to assure that the correct watering of plant materials is being accomplished through use of the irrigation system, hand-watering, 'gator' bags, water truck, etc.
- B. Contractor shall monitor settings of automatic sprinkler controls and make necessary adjustments according to climatic changes.
- C. Contractor shall not be responsible for supplemental watering areas that do not have irrigation systems, unless required by the Contract.
- D. Contractor shall be responsible for damages to irrigation system caused by mowing and other maintenance operations. Such damage will be repaired immediately at the Contractor's expense.

3.4 TREES, SHRUBS AND VINES

- A. **Watering Basins:**
 - 1. Maintain all watering basins around plants so that enough water can be applied to establish moisture through major root zones.
 - 2. In rainy season, open basins to allow surface drainage away from the root crown where excess water may accumulate. Restore watering basins at end of rainy season.

3. For supplemental hand watering of watering basins, use a water wand to break the water force. Do not permit crown roots to become exposed to air through dislodging of soil and mulch.
 4. Maintain originally called for depth of mulch to reduce evaporation and frequency of watering.
 5. Check for moisture penetration throughout the root zone at least once per week.
 6. To avoid root damage to young plants, minimize weed growth and protect any pre-emergent barriers, **cultivation of beds and tree wells will not be permitted.**
 7. Resetting: Reset plants to proper grades or upright position. Maintain staking and guying to insure plants remain upright.
- B. Weed Control:
- a. Control weeds with hand removal or the use of legally approved herbicides by the Town of Addison Parks Department.
 - b. All areas between plants, including watering basins, shall be weed free.
 - c. Use only recommended and legally approved organic herbicides to control weed growth.
 - d. **No soil cultivation will be permitted**
- C. Pruning:
1. Prune trees to select and develop permanent scaffold branches that are smaller in diameter than the trunk or branch to which they are attached, and which have vertical spacing of 18 in. to 48 in. and radial orientation so as not to overlay one another.
 2. Prune trees to eliminate diseased or damaged growth, and narrow V-shaped branch forks that lack strength. Reduce toppling and wind damage by thinning out crowns.
 3. Prune trees to maintain growth within space limitations, maintaining a natural appearance and balancing crown with roots.
 4. No stripping of lower branches ("raising up") of young trees will be permitted.
 5. Retain lower branches in a "tipped back" or pinched condition to promote caliper trunk growth (tapered trunk). Do not cut back to fewer than six buds or leaves on such branches. Only cut lower branches flush with the trunk after the tree is able to stand erect without staking or other support.
 6. Thin out and shape evergreen trees when necessary to prevent wind and storm damage. Do primary pruning of deciduous trees during the dormant season. Do not permit any pruning of trees prone to excessive "bleeding" during growth season.
 7. Prune damaged trees or those that constitute health or safety hazards at any time of year as required.
 8. Make all cuts clean and close to the trunk, without cutting into the branch collar. "Stubbing" will not be permitted. Cut smaller branches flush with trunk or lateral branch. Make larger cuts (1 in. in diameter or larger) parallel to shoulder rings, with the top edge of the cut at the trunk or lateral branch.
 9. Branches too heavy to handle shall be precut in three stages to prevent splitting or peeling of bark. Make the first two cuts 18 in. or more from the trunk to remove the branch. Make the third cut at the trunk to remove the resulting stub.
 10. Do not prune or clip shrubs into balled or boxed forms unless specifically called for by design. The use of hedge shears for the pruning of shrubs WILL NOT be allowed.

- D. Clip shrubs to be hedged when branches project 2 in. beyond limit of clipped hedge shown on the Drawings.

3.5 GROWDCOVERS

A. Watering:

1. Check for moisture penetration throughout the root zone at least twice a month.
2. Water as frequently as necessary to maintain healthy growth of ground covers.

B. Weed Control:

1. All planting areas will be maintained in a healthy weed-free condition by the use of legally approved pre- and post-emergent organic herbicides or hand-pulling. No soil cultivation will be permitted. In the case of heavy compaction, spading folks shall be used to loosen the soil without damaging the roots on the plant material. In these cases, the bed will be raked smooth and re-mulched.
2. Minimize hoeing of weeds in order to avoid plant damage.
3. Use only recommended and legally approved organic herbicides to control weed growth.

3.6 LAWNS

A. Watering:

1. Water lawns at such frequency as weather conditions require, replenishing soil moisture to 6 in. below root zone.
2. Apply enough water to newly sodded areas to wet the soil to a depth of 2"-3" (approx. ¼ inch in clay soils). In newly seeded areas; provide only enough water to keep the soil surface moist, but not water logged. In established lawn areas, apply enough water to wet the soil to a depth of 6" (approx. ½ inch in clay soils). These application rates are suggestions only. The frequency and actual duration of watering cycles will vary according to weather, soil type, slopes, etc. The contractor will be solely responsible for providing the optimum watering schedule for the project.

In sloped areas where runoff may be a problem, break each watering period into 3-4 shorter periods to allow better water absorption.

3. Watering shall be done during early mornings.

B. Weed Control:

1. All lawn areas will be maintained in a healthy weed-free condition by the use of legally approved pre- and post-emergent organic herbicides or hand-pulling.
2. In areas where crabgrass has infested the lawn, apply corn gluten meal within the seasonal parameters listed in Section 3.6.E.2
3. Use only recommended and legally approved organic herbicides to control weed growth. Do not irrigate for 48 hours after application of all herbicide sprays.
4. **NOTE: Inorganic herbicides may be used if in accordance with restrictions within the Edwards Aquifer Recharge Area.**

C. Mowing and Edging:

1. Mowing lawn/grass areas shall be accomplished with sharp, properly adjusted mowers of the correct size for the various areas
2. Mowing frequency shall be weekly. Blade heights shall be set according to the type of turf and weather conditions. Typically:

- Bermudagrass: 1 inch
- St. Augustinegrass: 2-1/2 inches
- Zoysia: 1 inch
- Ryegrass: 2 inches

3. Trim edges with each mowing or as required for neat appearance. Edging shall be performed with a blade type mechanical edger, shovel or herbicide. Line trimmers may only be used along walls and bed edges, not walks and curbs. Blow trimmings back into lawn area or collect and transfer to a designated compost area.
 4. A grass free clear space (edge) two (2") inches in width shall outline all obstacles.
- D. In the event of a prolonged rainy period and a surge of leaf growth is anticipated, the mower height may be re-adjusted to prevent "scalping" or skinning of lawn on preceding cuts. Never remove more than 1/3 of the leaf growth in a single mowing.

E. Top Dress Fertilizer: Applied during the establishment period at 45 Days after turf installation

1. Preparation: Immediately prior to top-dress application, cut lawn and leave clippings.
2. Application: Per 1000 square feet, apply fertilizer at following schedules and rates:

Product	40 Days	80 Days
*Corn Gluten Meal	Early Spring and Late Fall	20lbs
Slow Release Fertilizer	Mid Summer and Winter	20lbs

***IMPORTANT:** Corn Gluten Meal is a natural pre-emergent herbicide and fertilizer. DO NOT fertilize with Corn Gluten Meal if you will be seeding the area within 6 weeks of application. Use Slow Release Fertilizer approved by the Town of Addison if there is a conflict with a seeding or overseeding schedule and resume the above schedule during the next application. Thoroughly water in the gluten meal and allow to dry for 2 days immediately after application.

3. Reseeding of Lawn Areas: Match existing seed mix of adjacent areas.
 - a. Until the establishment of the turf, the Contractor will be responsible for replacing soils that have eroded onto the paved areas. Residual soils on paving will be removed and if not mingled with objectionable materials, may be re-used in eroded areas.
 - b. Immediately upon observing any lawn grass spreading into shrub or ground cover areas, the Contractor shall initiate a program of mechanical removal and maintain this program throughout the maintenance period.
 - c. Any lawn grass appearing in paved areas shall receive an application of or organic herbicides such as 25% acidic White Vinegar or Burn Out II® Weed and Grass Killer.
4. Special effort shall be given to the control of fire ants infesting the site. Use an organic product such as Garden-Ville brand Fire Ant Control. After control is accomplished, the ant mounds shall be lowered and tamped to the existing grade.

3.7 ANNUALS AND PERENNIALS

- A. Care for all seasonal color and perennial beds per established and horticultural practices. Failure to use horticultural practices may result in replacement of the plant material at the Contractor's expense.
- B. Weed Control: All planters with annuals and perennials shall be weed-free at all times.

C. Pruning:

1. Limit pruning to removal of damaged or dead twigs and foliage.
2. Remove spent flowers on a weekly basis.

D. Replacements of Annuals:

1. Replace annuals when materials exhibit a "spent" condition.
2. Thoroughly cultivate soil after removal of "spent" or "dead" plants prior to planting new materials.
3. Incorporate slow release fertilizers and rake smooth.

3.8 INSECTS, PESTS, AND DISEASE CONTROL

- A. Contractor shall be continuously alert for signs of insect presence or damage or the presence or damage from plant fungi. The Contractor shall immediately take action to control to infestation. Plant material that is damaged or that dies from insect or disease infestation while under the Contractor's care shall be immediately replaced at the Contractor's expense.
- B. Inspection: Inspect all plant materials weekly for signs of stress, damage and potential trouble from the following:
1. Presence of insects, moles, gophers, ground squirrels, snails and slugs in planting areas.
 2. Discolored or blotching leaves or needles.
 3. Unusually light green or yellowish green color inconsistent with normal green color of leaves.
- C. Personnel: Application of pesticides or beneficial insect release for insect, pest and disease control shall be performed by a certified pesticide applicator.
- D. Application: Spray with extreme care to avoid all hazards to any person or pet in the area or adjacent areas. **Notify the Owner's Representative at least 48 hours in advance of any pesticide application.**

3.9 IRRIGATION SYSTEM

A. General:

1. Repair, without charge to Owner, all damages to system caused by Contractor's operations. Perform all repairs within 24 hours.
2. Report promptly to Owner all accidental damage not resulting from Contractor's negligence or operations.
3. Do not run the irrigation system during periods of rain. Set and program automatic controllers for seasonal water requirements.
4. Twice a month, use a probe or other acceptable tool to check the rootball moisture of representative plants as well as the surrounding soil.

B. Cleaning and Monitoring the System:

1. Continually monitor the irrigation systems to verify that they are functioning properly as designed. Make program adjustments required by changing field conditions.
2. If applicable, clean pump filter and strainer once a year and as often as necessary to keep the irrigation systems free of sand and other debris.

3. Prevent spraying on windows, building walls, (game courts) by balancing the throttle control on the remote control valves and the adjustment screws on the sprinkler heads. Do not allow water to atomize and drift.

C. Winterization:

Normally, the irrigation system should be left operational during the winter. While the frequency may be as little as one cycle per month, the landscape will need supplemental water if winter rainfall is not adequate.

The irrigation system is designed to be completely drained to protect pipe from bursting prior to freezing temperatures. To adequately drain the system, the following procedure must be followed:

1. Air blow-out:
 - a. Set automatic control stations to 2-1/2 minutes timing.
 - b. Attach hose from portable air compressor to 1 in. air inlet installed on main line at backflow preventer.
 - c. Operate compressor at 100 cu. ft. per second at 60-80 PSI.
2. Manual drain valves: Open manual drain valves located at low points on the main line to drain main completely after air blow-out has been completed.
3. Backflow Preventer: Provide thermal insulation (heat tape) to protect vacuum barrier during the winter. Rotate backflow unit at unions and open pet cocks and drain. Reverse operation and tighten unions to resume irrigation.

3.10 OWNER ACCEPTANCE

A. Acceptance:

1. Work will be accepted by the Owner's Representative upon satisfactory completion of all work, but exclusive of replacement of materials under the Warranty Period.
2. Submit a written request to Owner's Representative for review for Final Acceptance at least five (5) working days prior to anticipated Final Review date.

B. Corrective Work:

1. Work requiring corrective action or replacement in the judgment of the Owner's Representative shall be performed within ten (10) calendar days after the review.
2. Corrective work and materials replacement shall be performed in accordance with the original Drawings and Specifications, and shall be made by the Contractor at no cost to the Owner.

3.11 CLEAN-UP

- A. All areas shall be kept neat and orderly at all times. Debris from maintenance operations shall be gathered and shall not be allowed to remain in place in excess of two (2) hours. Remove all such debris from the site at the end of each day.**

END OF SECTION

SECTION 32 14 16

BRICK UNIT PAVING

PART 1 - GENERAL

1.01 SECTION INCLUDES

- A. Brick pavers installed on sand setting bed.
- B. Mockups of three paver types. These mockups will be used in selecting brick type/color for the Work.

1.02 REFERENCE STANDARDS

- A. ASTM International (ASTM)
 - 1. ASTM C1272, Standard Specification for Heavy Vehicular Paving Brick.
 - 2. ASTM C33, Standard Specification for Concrete Aggregates.
 - 3. ASTM C144, Standard Specification for Aggregate for Masonry Mortar.

1.03 SUBMITTALS

- A. Product Data: For the following:
 - 1. Brick pavers.
 - 2. Bedding and Joint Materials.
 - 3. Edge restraints.
- B. Samples for Verification: Full-size units of each type of unit paver indicated; in sets for each color, texture, and pattern specified, showing the full range of variations expected in these characteristics.
- C. Qualification Data: For firms and persons specified in "Quality Assurance" Article to demonstrate their capabilities and experience. Include lists of completed projects with project names and addresses, names and addresses of architects and owners, and other information specified.

1.04 QUALITY ASSURANCE

- A. Installer Qualifications: An experienced installer who has completed unit paver installations similar in material, design, and extent to that indicated for this Project and whose work has resulted in construction with a record of successful in-service performance.
- B. Source Limitations: Obtain each type of unit paver, joint material, and setting material from one source with resources to provide materials and products of consistent quality in appearance and physical properties.
- C. Mockups: Before ordering bricks, prepare mockups of the three pavers specified. Locate mockups at a location acceptable to Owner and that is similar to the intended location of the Work. Minimum size of each mockup to be 3 ft x 8 ft.

Owner will select paver for Work following review of the mockups. Build mockups to comply with the requirements indicated for the completed Work, including same base construction, jointing and edge restraints.

1.05 DELIVERY, STORAGE AND HANDLING

- A. Protect unit pavers and aggregate during storage and construction against soiling or contamination from earth and other materials.

1.06 PROJECT CONDITIONS

- A. Cold-Weather Protection: Do not use frozen materials or materials mixed or coated with ice or frost. Do not build on frozen sub-grade or setting beds. Remove and replace unit paver work damaged by frost or freezing.
- B. Do not store materials in the median. Remove materials not incorporated into the Work at the end of each work day.

PART 2 - PRODUCTS

2.01 BRICK PAVERS – MEDIAN AREAS

- A. Heavy vehicular paving brick; ASTM C 1272, Type R, Application PS. Provide brick without frogs or cores in surfaces exposed to view in the completed Work.
- B. Manufacturer: Endicott Clay Products Company or approved equal.
- C. Paver Texture: wirecut
- D. Color Selection Options:
 - 1. Medium Ironspot #46
 - 2. Dark Ironspot
 - 3. Manganese Ironspot

2.02 BASE MATERIALS

- A. Cast in Place Concrete Base Slab: See Section for Miscellaneous Concrete.
- B. Geo-textile: Woven or non-woven geo-textile separation fabric manufactured from polyester or polypropylene fibers, with a permeability rating 10 times greater than that of soil on which paving is founded and an apparent opening size small enough to prevent passage of fines.
- C. Bedding Sand: 90% natural or crushed granite sand conforming to ASTM C33 and 10% Portland Cement, per Addison Public Works Standard Details.
- D. Joint Sand: Crushed granite sand conforming to ASTM C144 and a dry mix polymer based joint sand stabilizer. Joint sand stabilizer shall be approved by the Public Works Department prior to work.

PART 3 - EXECUTION**3.01 EXAMINATION**

- A. Examine areas indicated to receive paving, with Installer present, for compliance with requirements for installation tolerances and other conditions affecting performance. Proceed with installation only after unsatisfactory conditions have been corrected.

3.02 PREPARATION

- A. Clean concrete substrates to remove dirt, dust, and debris.
- B. Pre-plan layout of brick to minimize the number of small pieces in the work.

3.03 INSTALLATION, GENERAL

- A. Do not use unit pavers with chips, cracks, voids, discolorations, and other defects that might be visible or cause staining in finished work.
- B. Mix pavers from several pallets or cubes, as they are placed, to produce uniform blend of colors and textures.
- C. Cut unit pavers with motor-driven masonry saw equipment to provide clean, sharp, un-chipped edges. Cut units to provide pattern indicated and to fit adjoining work neatly. Use full units without cutting where possible. Hammer cutting is not acceptable.
- D. Joint Pattern: As indicated on the plans and details.
- E. Tolerances: Do not exceed 1/32-inch unit-to-unit offset from flush nor 1/8 inch in 10 feet from level, or indicated slope, for finished surface of paving.
- F. Expansion and Control Joints: Provide joint filler at locations and of widths indicated. Install joint filler before setting pavers.
- G. Provide concrete edge restraints as indicated. Install edge restraints before placing unit pavers.
- H. Final elevation of pavers is to be approximately 1/8 inch above adjoining curbs. Install pavers in one plane, sloped to drain.

3.04 SAND SETTING-BED PAVER APPLICATIONS

- A. Install concrete base slab over compacted sub-grade. Subgrade to be uniformly compact and at least 95 percent of ASTM D 1557 laboratory density.
- B. Provide 12 inch wide filter fabric strips to contain leveling course at joints in slab and edge restraint.
- C. Place leveling course and screed to a thickness of 1 inch taking care that moisture content remains constant and density is loose and constant until pavers are set and compacted.
- D. Set pavers with a butt joint, being careful not to disturb leveling base. If pavers have spacer bars, place pavers hand tight against spacer bars. Use string lines

to keep straight lines. Plan layout of brick to minimize the number of small pieces needed in the work. Units should be cut no smaller than 1/3 of whole paver. Notify Owner where smaller units may be required.

- E. Vibrate pavers into leveling course with a low-amplitude plate vibrator capable of a 3500- to 5000-lbf compaction force at 80 to 90 Hz. Perform at least three passes across paving with vibrator. Vibrate under the following conditions:
 - 1. After edge pavers are installed and there is a completed surface or before surface is exposed to rain.
 - 2. Before ending each day's work, fully compact installed concrete pavers to within 36 inches of the laying face. Cover open layers with non-staining plastic sheets to protect it from rain.
- F. Spread dry sand and fill joints immediately after vibrating pavers into leveling course. Vibrate pavers and add sand until joints are completely filled, then remove excess sand. Leave a slight surplus of sand on the surface for joint filling.
- G. Do not allow traffic on installed pavers until sand has been vibrated into joints.
- H. Repeat joint-filling process 30 days later.

3.05 REPAIR, CLEANING, AND PROTECTION

- A. Remove and replace unit pavers that are loose, chipped, broken, stained, or otherwise damaged or that do not match adjoining units as intended. Provide new units to match adjoining units and install in same manner as original units, with same joint treatment and with no evidence of replacement.
- B. Cleaning: Remove any residue from exposed paver surfaces. Wash and scrub clean.

END OF SECTION

SECTION 32 80 00

TOWN OF ADDISON LANDSCAPE IRRIGATION SPECIFICATIONS

Revised 11/14/11

These revised specifications supersede any and all others. However, any discrepancies between the approved construction plans and those of the Town **MUST** be brought to the attention of the Town's designated representative for a final determination. The contractor will present the Town's representative an as-built plan at the final walk-through, along with three Bucker VO75 quick coupling keys with hose-end swivels.

- 1.** All work is to be accomplished by or directly supervised at all times by an on-site Irrigator licensed by the State of Texas.
- 2.** The contractor shall verify the water pressure before the installation begins. If the static pressure is different than that of the design pressure, contact the designer and Town's representative immediately so changes can be made. Send a fax to the Parks dept. at 972-450-2834 with the current dated and timed static pressure reading. Design head to head with no single head coverage. Use appropriate size nozzles for a given landscape area so as not to spray onto or over paved surfaces or structures. Do not exceed manufacturer's recommendations.
- 3.** The irrigation installer is responsible for resetting head and/or box height due to settling and after turf, groundcover, shrubs, trees, and mulch is added to the landscape areas. The irrigation contractor must supply a workmanship warranty for (1) year from date of acceptance.
- 4.** Plans are diagrammatic and field adjustments are often necessary. For this reason, prior to trenching, valve locations and head layout with flags needs to be done and approved by the Town's irrigation inspector. Not doing so may result in the relocation of heads and/or valves at the irrigation contractor's expense.
- 5. Water Taps:** Water taps will be 2" in size. **Note:** This does not imply that a 2" meter will be used; see Water Meters below. All parts must conform to the Town of Addison Water Department specifications and are the responsibility of the irrigation contractor to provide. Inspection of taps by the Water Department Representative must occur. Excavation and tap permits are required. Contact the Town of Addison Water Department at (972) 450-2871.
- 6. Water Meters:** Only meter types approved by the Town of Addison Water Department with an electronic encoder register and touch pad reader and two (2) brass flanges are acceptable. Meter lay lengths must be in accordance with the Town of Addison Water Department's specifications, housed in appropriate size (to be determined by the Town's Irrigation Inspector) concrete box with lid. New stainless steel bolts and nuts must be used in the installation along with new neoprene gaskets. The box should be level with the final grade using concrete pavers to support and prevent sinking. Backfill inside the box, 3" below meter base with at least 6" of fine (1/2") pea gravel. Connection to main must be approved and inspected by the Town's Water Department Inspector and all tap materials are to be purchased at the expense of the contractor and must comply with the Town of Addison's specifications.

Note: Meter size shall not exceed 1 1/2" in size unless written approval is given by the Town of Addison Parks Department. All portions of this installation must adhere to the Town of Addison Water Department specifications as well.

7. Backflow Devices: Only Watts 007 M series or Febco 850 series inline check valve assemblies with the stainless steel ball valve handles and nuts are to be used. Irrigation contractor shall provide and install plugs for the test cocks in accordance to the Town of Addison Water Department specifications. Connect the device to the water meter via a separate brass flange, neoprene gasket and stainless steel nuts and bolts. Install to the flange a Teflon taped copper nipple and soldered copper pipe of sufficient length to center the DCA within its housing. The device will be housed in an appropriate size, (to be determined by the Town's Irrigation Inspector) rectangular concrete box with lid using concrete pavers for proper stability and height adjustment. The irrigation contractor shall be responsible for the DCA testing in accordance with State of Texas law, using a Licensed Backflow Assembly Tester registered with the Town of Addison Water Department. Copies of the results must be given to both the Town of Addison Parks and Water Departments.

Note: All portions of this installation must adhere to the Town of Addison Water Department specifications as well.

8. Sleeves: All paving must have Town approved sleeve sizes and quantities present. It is the responsibility of the irrigation contractor to notify the Town's Irrigation Inspector of any area where sleeves should be present but are not and provide such materials at his cost. Any paving installed without sleeves will necessitate a bore and subsequent materials at the irrigation contractor's expense. All sleeves 2" and smaller will be Schedule 40 PVC with size and location noted on the plan. Larger sizes will be Class 200. All piping underneath paving, including sidewalks, must be sleeved. All sleeves are to be belled end PVC pipe. A minimum length of 12 inches of sleeve material must extend beyond the pavement.

9. Glue and Primer: Use Turfite brand glue and a good quality purple primer on all PVC pipe and fittings. Avoid excessive use and wipe excess glue off of all joints and fittings with a clean rag.

10. Pipe: All main line pipe 2 inches and smaller is to be Schedule 40 belled PVC; larger sizes are to be Class 200 belled PVC with a minimum depth of 14" and a maximum depth of 16". Put not more than two (2) pipes in any one trench and separate the main line from the lateral line with at least two (2) inch of cover. Class 200 belled PVC lateral piping is to be used with a minimum depth of 12" and a maximum depth of 14".

11. Fittings: No crosses are permitted. Separate tees, 45's, elbows and other fittings by at least 12 inches. Reduction tees are preferred over use of single reducer bushings. Multiple reducer bushings will not be accepted. Only Spears and/or Lasco fittings are permitted. Allow 18 inches outside of sleeve before the first fitting. No 45 degree elbows on 1 inch and larger pipe are allowed.

12. Valves:

A. Master Valves: Every point of connection to the water supply system shall have an Irritrol 200 B series valve as the Master Valve, housed in a standard (large) Armor rectangular plastic valve box with 4-6 inches of (1/2") washed pea gravel placed underneath the valve in such a manner as to prevent soil infiltration into the box. The pea gravel must be 2 inches from

the bottom of the valve body. A minimum of 3" of valve box must extend below bottom of valve. If necessary, use valve box extensions. Use a good quality filter fabric to close off any openings between the valve box and PVC pipe. Use concrete pavers or bricks placed under edges of valve box for stability. Note: Valve box must not rest on pipe. A Blue wire shall be used as the station wire for the Master Valve.

B. Station Valves: Only Irritrol 200 B series valves are permitted. A Ball Valve will be installed before every station or zone valve. They are to be located within standard (large) Armor rectangular plastic valve boxes with 4-6 inches of ½" washed pea gravel placed underneath the valve in such a manner as to prevent soil infiltration into the box. The pea gravel must be 2 inches from the bottom of the valve body. A minimum of 3" of valve box must extend below bottom of valve. If necessary, use valve box extensions. Use a good quality filter fabric to close off any openings between the valve box and PVC pipe. Use concrete pavers or bricks placed under edges of valve box for stability. Note: Valve box must not rest on pipe.

C. Ball Valves: Female threaded plastic Spears or Lasco ball valves with positive T-handle cut off must be installed on every 200 feet of mainline for isolation purposes. A ball valve is also required to be installed before every station valves. Use 10" Armor valve box with a minimum of 3" extending below bottom of valve and fill to bottom of valve with a minimum of 4-6" of ½" washed pea gravel placed underneath the valve in such a manner as to prevent soil infiltration into the box. A minimum of 3" of valve box must extend below bottom of valve. If necessary, use valve box extensions. Use concrete pavers or bricks placed under edges of valve box for stability. Note: Valve box must not rest on pipe.

D. Quick Coupler Valves: Use only Buckner V075 single lug ¾" quick coupling valves with a metal top. They are to be connected to a threaded fitting. Teflon tape and appropriate length of gray schedule 80 nipples and schedule 40 fittings are to be used for the swing joint. Secure to 18 inch long by ½ inch thick steel rebar with a stainless steel worm screw clamp. House QCV in a 10 inch round plastic Armor valve box. Install Spears ball valve prior to each QCV. Bricks or pavers need to be installed under edges of valve boxes for stability. Backfill bottom of box with ½" washed pea gravel half way up body of valve. Note: Valve box must not rest on pipe.

E. Flowmeters: Purchase from a Rain Master supplier and install appropriately sized Data Industrial flowmeter. Follow all installation instructions as approved by Rain Master. House in a standard (large) Armor rectangular plastic valve box with 4-6 inches of ½" washed pea gravel placed underneath the valve in such a manner as to prevent soil infiltration into the box. Use concrete pavers or bricks placed under edges of valve box for stability. Note: Valve box must not rest on pipe. The irrigation contractor must also purchase from Rain Master and install shielded Rain Master EV-Cab-Sen flow meter cable and install within continuous ¾" or larger gray PVC conduit with 6 inch or larger J-boxes placed every 200 feet or where 360 degrees of fittings are installed; only sweep fittings are permitted. Only a continuous run of cable is allowed; no splices will be allowed except at the point of connection to the flow meter. Connections at the flow meter must first be soldered and then water proofed within a 3-M DBY connector. Note:

Certain Rain Master requirements must also be met regarding installation order and distances of separation between DCA, flow meter, master valve and the first fitting. It is the responsibility of the irrigation contractor to adhere to these requirements. At final walk through, proper operation of the flow meter at the Rain Master controller must be demonstrated by the irrigation contractor.

13. Heads: All heads shall be installed using polyethylene green nipples ($\frac{3}{4}$ "x6" for rotors and $\frac{1}{2}$ "x6" for pop-ups) screwed into threaded fittings unless noted otherwise. No swing joints on 4" pop-ups or rotors will be allowed. Note: In certain circumstances the Town of Addison may approve the use of 'funny pipe' in the installation of pop-up heads. The Town Inspector reserves the right to determine if and when 'funny pipe' will be allowed. When authorized, use Toro pipe with Toro barb fittings, and provide a minimum of 24" of 'funny pipe' between the threaded fitting and the head.

A. Pop-ups – Only Rainbird 1800 series are permitted. Install $\frac{3}{4}$ inch above the finished grade.

- a. **4 inch pop-ups:** turf, for tree bubblers within turf areas use Hunter PCN 10 bubbler nozzles on spray heads.
- b. **6 inch pop-ups** with no side inlet: very low ground cover (less than 6 inches at mature height).
- c. **12 inch pop-ups** with side inlet: Ground cover and low growing shrubs. The ground cover and shrubs should not be more than 12" at maturity. The Town Inspector reserves the right to determine if and when side inlets installed using 'funny pipe' verses the bottom inlet will be allowed.

B. Nozzles: Only Rainbird nozzles shall be acceptable unless otherwise noted in these specifications.

C. Bubblers - Use $\frac{1}{2}$ " Schedule 80 risers with shrub adapter and Hunter PCN 10, 1 gpm, bubbler nozzles for all tree wells with tree grates. Risers shall be a minimum of 2" below bottom of tree grates with nozzle 2" above mulch. Use (2) bubblers 180-degree opposed.

D. Rotors - Only Hunter PGP series are permitted, unless otherwise specified by the Town of Addison. Install $\frac{3}{4}$ " above finished grade.

14. Drip: Use Netafim products only. Use 0.6 gph pressure compensated self flushing dripper tubing with 12" emitter spacing. Install appropriate pressure reducer and filter in one standard rectangular plastic valve box and a ball valve (see Section 12 C) and station valve (see Section 12 B) in another standard rectangular plastic valve box. Use 17 mm Netafim barbed fittings. Secure tubing to the ground every 3' or less with heavy duty jute netting pins. Use air relief valves housed in 10" round valve boxes. Use Netafim indicator flags. Adhere to all Netafim design and installation specifications.

15. Risers: Use Sch 80 PVC with Weathermatic LXS Series shrub head adapters with a $\frac{1}{2}$ "x6" green poly cut-off nipple screwed into the threaded fitting in the ground.

The irrigation inspector reserves the right to determine placement of risers versus pop-ups.

16. Wiring: All wires will be 14 gauge UF. Station wires will be red. Common wires will be white. Master valve wire will be blue. Anytime the wiring changes direction, such as at an elbow or a tee, allow a loop of at least 12 inches alongside the fitting at that location. Only continuous wire runs are permissible. Wire should follow the main line where possible and lay along a single side not crossing over lateral lines. Wire is to be placed under mainline with 2" of dirt between wire and pipe.

17. Wire Connectors: Use only DBY connectors for all field wire splices other than at the valves themselves. Allow at least 36 inches of pigtailed wire at each splice. Use King One Step tan colored connectors for all valve splices. All valve box splices are to be housed in standard (large) Armor rectangular plastic valve boxes. All field splices are to be in 10 inch round Ametek plastic valve boxes or standard, large rectangular Ametek plastic valve boxes at the discretion of the Town's representative.

18. Backfilling: Prior to any backfilling of trenches, an inspection by the Town's irrigation representative must take place and any necessary changes implemented; otherwise manual excavation to enable proper inspection will be necessary. Use clean and approved topsoil to backfill all pipe to a depth. All heads and boxes are to be backfilled to grade with clean topsoil. No rocks greater than 1 inch are allowed. Compact trenches to alleviate settling. Minimal depth of coverage is 12 inches.

19. Valve sequencing must be performed by the contractor and in an order approved by the Town Irrigation Inspector. At least 12 inches of extra station wiring within the bottom of the pedestal is necessary for each zone and must be of neat and orderly appearance.

20. Any deficiencies in coverage noted by the Town's irrigation inspector will be rectified at the cost of the contractor.

21. Controller: A Town irrigation representative will determine the type of controller to be used. All controllers shall have a concrete pad of 36"x36"x6". Pad will be set at 3" above final grade. Install the controller after the concrete pad is completely cured (two days). Use only appropriately sized stainless steel bolts, washers and nuts to secure the controller to the concrete pad. All wiring is to enter the pedestal via appropriately sized PVC sweep elbows extending at least 1" thru and 6" out from under the pad. Control/master valve wiring, flow meter wiring and 120-V service wiring are to be separated with each having its own access elbow. An additional spare ¾" sweep elbow for phone service is to be installed as well. All national and local codes must be followed during the installation.

- A. A/C controller** - Only appropriately sized Weathematic SL-1600 SmartLine controllers installed with a stainless steel SLPED-ENC cabinet on a stainless steel SLPED-1600 pedestal will be acceptable. A Weathermatic SLW-10 weather station will need to be professionally installed on a 2" galvanized pole securely cemented a minimum of 36" into the ground and placed where it can operate properly and hardwired to the controller. All non-Rain Master controllers must be permanently wired for quick attachment to a Rain Master remote control unit.

B. Battery and/or Solar Operated Controllers - Only LEIT controllers will be acceptable. Install rain or freeze sensors on these controllers with SKIT8821-4 installation kit. Install on galvanized thick wall poles and set controller panel to height above finished grade to be determined by Town's representative.

C. Rain Master: Only an approved size stainless steel Rain Master Evolution DX-2 controller with a Stainless Steel Pedestal and Heavy Duty Lightning/Surge Protection is permitted. The controller must include all necessary hardware to ensure reliable communication and operation with the Town's central control located at 16801 Westgrove. Installation must include the following Rain Master hardware, purchased only from a certified Rain Master supplier: DX-FLOW sensor board, DX-PH phone communication option, Data Industrial flow meter (same size as the mainline), and shielded EV-CAB-SEN (see section '12. Valves:', subsection 'E. Flowmeters' above for specifics to this installation) flow meter cable. It is the irrigation contractor's responsibility to entail the cost of and work in conjunction with the Town of Addison Parks Department and AT&T Telephone to establish a dedicated phone service and install an interface within the pedestal at each controller location. The contractor is responsible for installing AT&T approved direct burial rated phone cable within 1" Schedule 40 gray PVC conduit, fittings, and sweep elbows from the location of the phone service and into the controller cabinet. The entire installation must conform to Rain Master specifications and be approved by the Town's irrigation inspector prior to and be inspected during installation. Such specifications will include Rain Master approved grounding and pad configurations and distances of separation from water meter to DCA to master valve to flow meter and the first fitting. A functional Mini-click freeze and rain sensor with a Hunter bypass switch must be installed in an approved location and by an approved method. For technical questions, part numbers and pricing of any Rain Master equipment, contact Ray Schramm of John Deere GreenTech at (214) 347-3628.

22. Communication is the key. If you are unsure, CALL Ron Lee, the Operations Manager of the Addison Parks Department: Office (972) 450-2863/Cell (972) 672-1817.

SECTION 32 91 19

LANDSCAPE GRADING

PART 1 GENERAL

1.1 SECTION INCLUDES

- A. Filling, backfilling, and compacting for footings, slabs-on-grade, paving, and site structures.
- B. Backfilling and compacting for utilities outside the building to utility main connections.
- C. Filling holes, pits, and excavations generated as a result of removal (demolition) operations.

1.2 RELATED SECTIONS

- A. Section 32 93 00 – Landscape Planting.

1.3 REFERENCES

- A. AASHTO T 180 - Standard Specification for Moisture-Density Relations of Soils Using a 4.54 kg (10-lb) Rammer and a 457 mm (18 in.) Drop; American Association of State Highway and Transportation Officials; 2001.
- B. ASTM C 136 - Standard Test Method for Sieve Analysis of Fine and Coarse Aggregates; 2001.
- C. ASTM D 698 - Standard Test Methods for Laboratory Compaction Characteristics of Soil Using Standard Effort (12,400 ft-lbf/ft³ (600 kN-m/m³)); 2000a.
- D. ASTM D 1556 - Standard Test Method for Density and Unit Weight of Soil in Place by the Sand-Cone Method; 2000.
- E. ASTM D 1557 - Standard Test Methods for Laboratory Compaction Characteristics of Soil Using Modified Effort (56,000 ft-lbf/ft³ (2,700 kN m/m³)); 2002.
- F. ASTM D 2167 - Standard Test Method for Density and Unit Weight of Soil in Place by the Rubber Balloon Method; 1994(R 2001).
- G. ASTM D 2487 - Standard Practice for Classification of Soils for Engineering Purposes (Unified Soil Classification System); 2000.
- H. ASTM D 2922 - Standard Test Methods for Density of Soil and Soil-Aggregate in Place by Nuclear Methods (Shallow Depth); 2001.
- I. ASTM D 3017 - Standard Test Method for Water Content of Soil and Rock in Place by Nuclear Methods (Shallow Depth); 2001.

1.4 DEFINITIONS

- A. Finish Grade Elevations: Indicated on drawings.
- B. Subgrade Elevations: Will be left 6 inches below finish grade elevations in lawn and seeded areas, as indicated on drawings; and 6 inches below finish grade in planting areas, as indicated on drawings, unless otherwise indicated.

1.5 SUBMITTALS

- A. See Division 01 - Administrative Requirements, for submittal procedures.
- B. Fill Composition Test Reports: Results of laboratory tests on proposed and actual materials used.
- C. Compaction Density Test Reports.

1.6 PROJECT CONDITIONS

- A. Provide sufficient quantities of fill to meet project schedule and requirements. When necessary, store materials on site in advance of need.
- B. When fill materials need to be stored on site, locate stockpiles where indicated.
 - 1. Separate differing materials with dividers or stockpile separately to prevent intermixing.
 - 2. Prevent contamination.
 - 3. Protect stockpiles from erosion and deterioration of materials.
- C. Verify that survey bench marks and intended elevations for the Work are as indicated.

PART 2 PRODUCTS

2.1 FILL MATERIALS

- A. General Fill: Subsoil excavated on-site (Provide borrow soil materials when sufficient satisfactory soils materials are not available from excavations).
 - 1. Graded.
 - 2. Free of lumps larger than 3 inches, rocks larger than 2 inches, and debris.
 - 3. Conforming to ASTM D 2487 Group Symbol CL.
- B. Granular Fill: Coarse aggregate, conforming to State of Texas Highway Department standard.
- C. Sand: Natural river or bank sand; washed; free of silt, clay, loam, friable or soluble materials, and organic matter.
 - 1. Grade in accordance with ASTM D 2487 Group Symbol SW.
- D. Topsoil: Dark brown friable loamy topsoil, screened to remove rocks, clay lumps, clods, vegetative material.

2.2 ACCESSORIES

- A. Geotextile Fabric: Non-biodegradable, woven.
- B. Vapor Retarder: 10 mil thick, polyethylene.

2.3 SOURCE QUALITY CONTROL

- A. See Division 01 - Quality Assurance, for general requirements for testing and analysis of soil material.
- B. Where fill materials are specified by reference to a specific standard, test and analyze samples for compliance before delivery to site.
- C. If tests indicate materials do not meet specified requirements, change material and retest.
- D. Provide materials of each type from same source throughout the Work.

PART 3 EXECUTION

3.1 EXAMINATION

- A. Identify required lines, levels, contours, and datum locations.

- B. Verify subdrainage, dampproofing, or waterproofing installation has been inspected.
- C. Verify structural ability of unsupported walls to support imposed loads by the fill.

3.2 PREPARATION

- A. Protect structures, utilities, sidewalks, pavements, and other facilities from damage caused by Work.
- B. Protect subgrades and foundation soils against freezing temperatures or frost. Provide protective insulating materials as necessary.
- C. Provide erosion-control measures to prevent erosion or displacement of soils and discharge of soil-bearing water runoff or airborne dust to adjacent properties and walkways.
- D. Reconstruct subgrades damaged by freezing temperatures, frost, rain, accumulated water, or construction activities, as directed by Landscape Architect.
- E. Scarify and proof roll subgrade surface to a depth of 6 inches to identify soft spots.
- F. Cut out soft areas of subgrade not capable of compaction in place. Backfill with general fill.
- G. Compact subgrade to density equal to or greater than requirements for subsequent fill material.
- H. Until ready to fill, maintain excavations and prevent loose soil from falling into excavation.

3.3 DEWATERING

- A. Prevent surface water and ground water from entering excavations, from ponding on prepared subgrades, and from flooding Project site and surrounding area.
- B. Protect subgrades from softening, undermining, washout, and damage by rain or water accumulation.
 - 1. Reroute surface water runoff away from excavated areas. Do not allow water to accumulate in excavations. Do not use excavated trenches as temporary drainage ditches.
 - 2. Install a dewatering system to keep subgrades dry and convey ground water away from excavations. Maintain until dewatering is no longer required.

3.4 FILLING

- A. Place and compact backfill in excavations promptly, but not before completing the following:
 - 1. Construction below finish grade including, where applicable, dampproofing, waterproofing, and perimeter insulation.
 - 2. Surveying locations of underground utilities and record documents.
 - 3. Inspecting and testing underground utilities.
 - 4. Removing trash and debris.
 - 5. Removing vegetation, topsoil, unsatisfactory soil materials, obstructions, and deleterious materials.
 - 6. Removing concrete formwork.
 - 7. Removing temporary shoring and bracing and sheeting.
 - 8. Installing permanent or temporary horizontal bracing on horizontally supported walls.
- B. Fill to contours and elevations indicated using unfrozen materials.
- C. Employ a placement method that does not disturb or damage other work.

- D. Systematically fill to allow maximum time for natural settlement. Do not fill over porous, wet, frozen or spongy subgrade surfaces.
- E. Maintain optimum moisture content of fill materials to attain required compaction density.
- F. Granular Fill: Place and compact materials in equal continuous layers not exceeding 6 inches compacted depth.
- G. Soil Fill: Place and compact material in equal continuous layers not exceeding 8 inches compacted depth.
- H. Slope grade away from building minimum 2 inches in 10 ft, unless noted otherwise. Make gradual grade changes. Blend slope into level areas.
- I. Correct areas that are over-excavated.
 - 1. Load-bearing foundation surfaces: Use structural fill, flush to required elevation, compacted to 100 percent of maximum dry density.
 - 2. Other areas: Use general fill, flush to required elevation, compacted to minimum 97 percent of maximum dry density.
- J. Compaction Density Unless Otherwise Specified or Indicated:
 - 1. Under paving, slabs-on-grade, and similar construction: 95 percent of maximum dry density.
- K. Reshape and re-compact fills subjected to vehicular traffic.

3.5 FILL AT SPECIFIC LOCATIONS

- A. Use general fill unless otherwise specified or indicated.
- B. At Foundation Walls and Footings:
 - 1. Use Structural Fill.
 - 2. Fill up to subgrade elevation.
 - 3. Compact each lift to 95 percent of maximum dry density.
 - 4. Do not backfill against unsupported foundation walls.
 - 5. Backfill simultaneously on each side of unsupported foundation walls until supports are in place.
- C. Over Subdrainage Piping at Foundation Perimeter and Under Slabs:
 - 1. Cover drainage fill with general fill.
 - 2. Fill up to subgrade elevation.
 - 3. Compact to 95 percent of maximum dry density.
- D. Over Buried Utility Piping and Conduits in Trenches:
 - 1. Bedding: Use granular fill.
 - 2. Cover with general fill.
 - 3. Fill up to subgrade elevation.
 - 4. Compact in maximum 8 inch lifts to 95 percent of maximum dry density.
- E. At Lawn Areas:
 - 1. Use general fill.

2. Fill up to subgrade elevations.
 3. Compact to 85 percent of maximum dry density.
 4. See Section 32 93 00 – Landscape Planting for topsoil placement.
- F. At Planting Areas Other Than Lawns:
1. Use general fill.
 2. Fill up to subgrade elevations.
 3. Compact to 85 percent of maximum dry density.
 4. See Section 32 93 00 – Landscape Planting for topsoil placement.

3.6 MOISTURE CONTROL

- A. Uniformly moisten or aerate subgrade and each subsequent fill or backfill layer before compaction to within 2 percent of optimum moisture content.
1. Do not place backfill or fill material on surfaces that are muddy, frozen, or contain frost or ice.
 2. Remove and replace, or scarify and air-dry, otherwise satisfactory soil material that exceeds optimum moisture content by 2 percent and is too wet to compact to specified dry unit weight

3.7 COMPACTION OF BACKFILLS AND FILLS

- A. Place backfill and fill materials in layers not more than 8 inches (200 mm) in loose depth for material compacted by heavy compaction equipment, and not more than 4 inches (100 mm) in loose depth for material compacted by hand-operated tampers.
- B. Place backfill and fill materials evenly on all sides of structures to required elevations, and uniformly along the full length of each structure.
- C. Compact soil to not less than the following percentages of maximum dry unit weight according to ASTM D 698:
1. Under structures, foundations, footings, building slabs, steps, and pavements, scarify and recompact top 12 inches (300 mm) of existing subgrade and each layer of backfill or fill material at 95 percent.
 2. Under walkways, scarify and recompact top 6 inches (150 mm) below subgrade and compact each layer of backfill or fill material at 92 percent.
 3. Under lawn or unpaved areas, scarify and recompact top 6 inches (150 mm) below subgrade and compact each layer of backfill or fill material at 85 percent.

3.8 TOLERANCES

- A. Top Surface of General Filling: Plus or minus 1 inch from required elevations.

3.9 FIELD QUALITY CONTROL

- A. See Section 01 40 00 - Quality Requirements and Section 01 45 23 – Testing and Inspection Services, for general requirements for field inspection and testing.
- B. Perform compaction density testing on compacted fill in accordance with ASTM D1556, ASTM D2167, ASTM D2922, or ASTM D3017.
- C. Evaluate results in relation to compaction curve determined by testing uncompacted material in accordance with ASTM D 698 ("standard Proctor"), ASTM D 1557 ("modified Proctor"), or

AASHTO T 180.

- D. If tests indicate work does not meet specified requirements, remove work, replace and retest.
- E. Proof roll compacted fill at surfaces that will be under slabs-on-grade.

3.10 CLEAN-UP

- A. Remove unused stockpiled materials, leave area in a clean and neat condition. Grade stockpile area to prevent standing surface water.
- B. Leave borrow areas in a clean and neat condition. Grade to prevent standing surface water.

END OF SECTION

SECTION 32 92 19

SEEDING

PART 1 GENERAL

1.1 SECTION INCLUDES

- A. Preparation of subsoil.
- B. Hydromulching for Lawn.
- C. Drill Seeding for Native Grass / Wildflower Areas.

1.2 RELATED SECTIONS

- A. Section 32 93 00 – Landscape Planting

1.3 DEFINITIONS

- A. Weeds: Any plant life not specified or scheduled.

1.4 SUBMITTALS

- A. See Division 01 - Administrative Requirements, for submittal procedures.
- B. Seed Source (Certifications).
 - 1. If using native grass or wildflower seed, seed must have been harvested within one hundred (100) miles of the construction site.
- C. Topdress Fertilizer (Certifications).

1.5 REGULATORY REQUIREMENTS

- A. Comply with regulatory agencies for fertilizer and herbicide composition.

1.6 DELIVERY, STORAGE, AND HANDLING

- A. Deliver grass seed mixture in sealed containers. Seed in damaged packaging is not acceptable. Deliver seed mixture in containers showing percentage of seed mix, year of production, net weight, date of packaging, and location of packaging.
- B. Deliver fertilizer in waterproof bags showing weight, chemical analysis, and name of manufacturer.

1.7 INSPECTIONS

- A. Make written request for inspection of finish grade prior to hydromulching.
- B. Make written request for inspection that hydromulching operations have been completed. Such inspection is for the purpose of establishing the Maintenance Period.
- C. Submit written requests for inspections to the Landscape Architect at least seven (7) days prior to anticipated inspection date.

1.8 WARRANTY PERIOD

- A. **Time Period:** Warrant that all lawns and grasses shall be in a healthy and flourishing condition of active growth six (6) months from date of Final Acceptance.
- B. **Appearance During Warranty:**
 - 1. **Lawns:** Shall be free of dead or dying patches, and all areas shall show foliage of a normal density, size and color. Complete lush cover with no brown sections or cracks showing.
- C. **Delays:** All delays in completion of planting operations which extend the planting into more than one planting season shall extend the Warranty Period correspondingly.
- D. **Exceptions:** Contractor shall not be held responsible for failures due to neglect by Owner, vandalism, etc., during Warranty Period. Report such conditions in writing.
- E. **Replacements:** Replace, without cost to Owner, and as soon as weather conditions permit, all lawns and grasses not in a vigorous, thriving condition, as determined by Landscape Architect during and at the end of Warranty Period.

1.9 FINAL ACCEPTANCE

- A. Work under this Section will be accepted by Landscape Architect upon satisfactory completion of all work, but exclusive of re-application under the Guarantee Period.

PART 2 PRODUCTS

2.1 SEED MIXTURE

- A. **Composition:** Fresh, clean, certified, Class 'A', new crop seed.
- B. **Lawn Seed Mixture:** The mixture to be used shall be proportioned by weight and consist of the following varieties to be sown at the rate of six (6) pounds per 1,000 square feet (210 pounds per acre): [Weed seed not to exceed 0.25%]
 - 1. **Common Bermuda:** 85% percent; 98% purity; 90% min. germination.
 - 2. **Perennial Ryegrass:** 10% percent; 98% purity; 90% min. germination.
 - 3. **Annual Ryegrass:** 5% percent; 95% purity; 90% min. germination.
- C. **Native Grass / Wildflower Mixes:**
 - 1. **Native Sun Turfgrass – Native American Seed, Junction, Texas 1-800 728-4043**
 - 2. **Blackland Prairie Mix - Native American Seed, Junction, Texas 1-800 728-4043**
 - 3. **Weeping Lovegrass - Native American Seed, Junction, Texas 1-800 728-4043**

2.2 SOIL MATERIALS

- A. **Topsoil:** As specified in Section 32 91 19

2.3 ACCESSORIES

- A. **Mulching Material:** Prepared wood cellulose fiber, dust form, free of growth or germination inhibiting ingredients.
- B. **Fertilizer:** Complete Commercial Fertilizer; recommended for grass, with fifty percent of the elements derived from organic sources; of proportion necessary to

eliminate any deficiencies of topsoil, as indicated by analysis.

- C. **Water:** Clean, fresh and free of substances or matter which could inhibit vigorous growth of grass.
- D. **Erosion Fabric:** Curlex or Curlex 2 matting where necessary to prevent soil erosion.

PART 3 EXECUTION

3.1 EXAMINATION

- A. Verify that prepared soil base is ready to receive the work of this Section.

3.2 PREPARATION

- A. Prepare subgrade in accordance with Section 32 93 00 – Landscape Planting.
- B. Place topsoil in accordance with Section 32 93 00 – Landscape Planting.
- C. **Final Grading**
 - 1. **Stones, Weeds, Debris:** Verify that all areas to receive lawns (as indicated in Drawings) are clear of stones larger than 1" diameter, weeds, debris and other extraneous materials.
 - 2. **Grades:** Verify that grades are within 1", plus or minus, of the required finished grades. Verify that soil preparation and fertilization has been installed in another section. Report all variations in writing.
- D. **Soil Moisture:**
 - 1. **Excessive Moisture:** Do not commence work of this section when soil moisture content is so great that excessive compaction will occur, nor when it is so dry that dust will form in air or clods will not break readily.
 - 2. **Inadequate Moisture:** Apply water, as necessary, to bring soil to an optimum moisture content for planting.

3.3 SEEDING ON PREPARED FINISHED GRADE (Hydromulching)

- A. **Bed Preparation:** Immediately after the finished grade has been approved, begin hydroseeding operation to reduce excessive weed growth.
- B. **Special Mulching Equipment:** Hydraulic equipment used for the application of fertilizer, seed, and slurry of prepared wood fiber mulch shall have a built-in agitation system with an operating capacity sufficient to agitate, suspend, and homogeneously mix a slurry containing up to forty (40) pounds of fiber plus a combined total of seventy (70) pounds of fertilizer solids for each one hundred (100) gallons of water. The slurry distribution lines shall be large enough to prevent stoppage. The discharge line shall be equipped with a set of hydraulic spray nozzles which provide even distribution of the slurry on the slopes to be seeded. The slurry tank shall have a minimum capacity of eight hundred (800) gallons and shall be mounted on a traveling unit which may be either self-propelled or drawn with a separate unit which will place the slurry tank and spray nozzles within sufficient proximity to the areas to be seeded so as to provide uniform distribution without waste. The Landscape Architect may authorize equipment with smaller tank capacity provided that the equipment has the necessary agitation system and sufficient pump capacity to spray the slurry in a uniform coat.

- C. **Mixing:** Care shall be taken that the slurry preparation takes place on the site of the work. The slurry preparation should begin by adding water to the tank when the engine is at half throttle. When the water level has reached the height of the agitator shaft, good recirculation shall be established and seed shall be added. Fertilizer shall then be added, followed by wood pulp mulch. The wood pulp mulch shall only be added to the mixture after the seed and when the tank is at least one-third filled with water. The engine throttle shall be opened to full speed when the tank is half filled with water. All the wood pulp mulch shall be added by the time the tank is two-thirds to three-fourths full. Spraying shall commence immediately when the tank is full.
- D. **Application:**
1. Contractor shall obtain approval of hydromulch area preparation from the Landscape Architect prior to application.
 2. Operators of hydromulching equipment shall be thoroughly experienced in this type of application.
 3. The operator shall apply the specified slurry mix in a motion to form a uniform, visible mat at specified rate, using the green color of the wood pulp as a guide.
 4. Keep hydromulch within areas designated and keep from contact with other plant material.
 5. Slurry mixture which has not been applied within four (4) hours of mixing shall not be used and shall be removed from the site.
 6. Immediately after application, thoroughly wash off any plant material, planting areas, or paved areas not intended to receive slurry mix. Keep all paved and planting areas clean during maintenance operations.
- E. **Unseeded Areas:** If, in the opinion of the Landscape Architect, unplanted skips and areas are noted after hydromulching, the Contractor shall be required to seed the unplanted areas with the grasses that were to have been planted at no additional cost to the Owner.

3.3 SEEDING ON PREPARED FINISHED GRADE (Drill Seeding)

- A. **Bed Preparation:** Immediately after the finished grade has been approved, begin seeding operation to reduce excessive weed growth.
- B. **Mechanically Seeding:**
1. All Native Grass / Wildflower areas, as designated in Drawings, are to be drill seeded.
 2. All varieties of seed, as well as fertilizer, may be distributed at the same time provided that each component is uniformly applied at the specified rate.
 3. The seed or seed mixture specified shall be uniformly distributed over the areas shown on the plans or where indicated.
 4. Seed shall be drilled at a depth of from one quarter (1/4") inch to three eighths (3/8") inch utilizing a three-basket, pasture or rangeland type seed driller.
 5. All drilling is to be on the contour.
 6. After planting, the area shall be rolled with a roller integral to the seed drill, or a corrugated roller of the "Cultipacker" type. All rolling of slope areas shall be on contour.

- C. Do not seed areas in excess of that which can be rolled on same day.
- D. Planting Season: Between March 1 and May 31 or between September 1 and December 1.
- E. Do not sow immediately following rain, when ground is too dry, or during windy periods.
- F. Apply water with a fine spray immediately after each area has been seeded. Saturate to 4 inches of soil.

3.4 SEED PROTECTION

- A. After application, the Contractor shall not operate any equipment over the covered area.
- B. Cover seeded slopes where grade is 4 inches per foot or greater with erosion fabric. Roll fabric onto slopes without stretching or pulling.
- C. Lay fabric smoothly on surface, bury top end of each section in 6 inch deep excavated topsoil trench. Provide 12 inch overlap of adjacent rolls. Backfill trench and rake smooth, level with adjacent soil.
- D. Secure outside edges and overlaps at 36 inch intervals with stakes.
- E. Lightly dress slopes with topsoil to ensure close contact between fabric and soil.
- F. At sides of ditches, lay fabric laps in direction of water flow. Lap ends and edges minimum 6 inches.

3.5 MAINTENANCE

- A. Refer to section 32 01 90

3.6 INSPECTIONS

- A. Make written request for inspection after areas have been seeded and sodded.
- B. Submit requests for inspections to Landscape Architect at least two (2) days prior to anticipated inspection date.

3.7 CLEAN-UP

- A. General: Keep all areas of work clean, neat and orderly at all times. Keep all paved areas clean during planting operations.
- B. Debris: Clean up and remove all deleterious materials and debris from the entire work area prior to Final Acceptance.

END OF SECTION

SECTION 329223

SODDING

PART 1 GENERAL

1.1 SECTION INCLUDES

- A. Preparation of subsoil.
- B. Sod installation.

1.2 RELATED SECTIONS

- A. Section 32 93 00 – Landscape Planting

1.3 REFERENCES

- A. TPI (SPEC) - Guideline Specifications to Turfgrass Sodding; Turfgrass Producers International; 1995.

1.4 SUBMITTALS

- A. See Division 01 - Administrative Requirements, for submittal procedures.
- B. Certification: Submit certification of grass species and location of sod source.

1.5 QUALITY ASSURANCE

- A. Sod Producer: Company specializing in sod production and harvesting with minimum five years experience, and certified by the State of Texas.
- B. Installer Qualifications: Company approved by the sod producer.

1.6 DELIVERY, STORAGE, AND HANDLING

- A. Deliver sod on pallets. Protect exposed roots from dehydration.
- B. Do not deliver more sod than can be laid within 24 hours.

1.7 INSPECTIONS

- A. Make written request for inspection of finish grade prior to sodding.
- B. Make written request for inspection that sodding operations have been completed. Such inspection is for the purpose of establishing the Maintenance Period.
- C. Submit written requests for inspections to the Landscape Architect at least seven (7) days prior to anticipated inspection date.

1.8 WARRANTY PERIOD

- A. Time Period: Warrant that all lawns and grasses shall be in a healthy and flourishing condition of active growth six (6) months from date of Final Acceptance.
- B. Appearance During Warranty: Lawns shall be free of dead or dying patches, and all areas shall show foliage of a normal density, size and color. Complete lush cover with no brown sections or cracks showing.

- C. Delays: All delays in completion of planting operations which extend the planting into more than one planting season shall extend the Warranty Period correspondingly.
- D. Exceptions: Contractor shall not be held responsible for failures due to neglect by Owner, vandalism, etc., during Warranty Period. Report such conditions in writing.
- E. Replacements: Replace, without cost to Owner, and as soon as weather conditions permit, all lawn and grasses not in a vigorous, thriving condition, as determined by Landscape Architect during and at the end of Warranty Period.
- F. Matching: Closely match all replacement sod with adjacent areas of lawn or grass. Apply all requirements of this Specification to all replacements

1.9 FINAL ACCEPTANCE

- A. Work under this Section will be accepted by Landscape Architect upon satisfactory completion of all work, but exclusive of re-application under the Guarantee Period.

PART 2 PRODUCTS

2.1 MATERIALS

- A. Sod: TPI, Certified Turfgrass Sod quality; cultivated grass sod; type indicated in plant schedule on Drawings; with strong fibrous root system, free of stones, burned or bare spots, relatively free of thatch; free from diseases and harmful insects; containing no more than 5 grassy and/or broadleaf weeds per 1000 sq ft; . Minimum age of 18 months, with root development that will support its own weight without tearing, when suspended vertically by holding the upper two corners.
- B. Sod shall be rejected if found to contain the following weeds: Quackgrass, johnsongrass, poison ivy, nimbleweed, thistle, bindweed, bentgrass, perennial sorrel, brome grass.
- C. Topsoil: As specified in Section 32 93 00 – Landscape Planting.

2.2 ACCESSORIES

- A. Wood Pegs: Softwood, sufficient size and length to ensure anchorage of sod on slope.
- B. Wire Mesh: Interwoven hexagonal metal wire mesh of 2 inch size.

2.3 HARVESTING SOD

- A. Machine cut sod in accordance with TPI Guidelines.
- B. Cut sod in area not exceeding 1 sq yd, with minimum 1/2 inch and maximum 1 inch topsoil base.

PART 3 EXECUTION

3.1 SOD BED PREPARATION

- A. Prepare subgrade in accordance with Section 32 93 00 – Landscape Planting.
- B. Final Grading

1. **Stones, Weeds, Debris:** Verify that all areas to receive lawns are clear of stones larger than 1-1/2 in. diameter, weeds, debris and other extraneous materials.
 2. **Grades:** Verify that grades are within 1 in. plus or minus of the required finished grades. Verify that soil preparation and fertilization has been installed in another section. Report all variations in writing.
 3. **Rake areas to set exact line and final finish grade.**
- C. **Rolling:** Roll amended soil with 200 pound water-ballast roller.
- D. **Soil Moisture:**
1. **Excessive Moisture:** Do not commence work of this section when soil moisture content is so great that excessive compaction will occur, nor when it is so dry that dust will form in air or that clods will not break readily.
 2. **Inadequate Moisture:** Apply water, as necessary, to bring soil to an optimum moisture content for planting, immediately prior to laying the sod.
- E. **Timing:** Sod immediately thereafter, provided the sod-bed has remained friable.

3.2 LAYING SOD

- A. **Moisten prepared surface immediately prior to laying sod.**
- B. **Lay sod within 24 hours after harvesting. Sod over 24 hour old will be removed from the site immediately.**
- C. **Lay the first row of sod in a straight line, with subsequent rows parallel to and set tight with no open joints visible, and no overlapping; stagger lateral joints 12 inches minimum. Do not stretch or overlap sod pieces.**
- D. **Lay smooth.**
- E. **Cut sod to fit curves with a sharp knife.**
- F. **Place top elevation of sod 1/2 inch below adjoining edging.**
- G. **On berms and slopes lay sod with strips parallel to contours.**
- H. **On slopes four inches per foot and steeper, lay sod perpendicular to slope and secure every row with wooden pegs at maximum 1 1/2 feet on center. Drive pegs flush with soil portion of sod.**
- I. **Water sodded areas immediately after installation. Saturate sod to 6 inches of soil.**
- J. **After sod and soil have dried, roll sodded areas to ensure good bond between sod and soil and to remove minor depressions and irregularities. Roll sodded areas with roller not exceeding 200 lbs .**
- K. **Immediately after installation of the sod, remove sod clumps and soil, wash off any plant materials and pavements not to have sod. Keep all areas clean during the maintenance period.**

3.3 CLEAN-UP

- A. **General:** Keep all areas of work clean, neat and orderly at all times. Keep all paved areas clean during planting operations.
- B. **Debris:** Clean up and remove all deleterious materials and debris from the entire work area prior to Final Acceptance.

END OF SECTION

SECTION 32 93 00
LANDSCAPE PLANTING

PART 1 GENERAL

1.1 SECTION INCLUDES

- A. Preparation of subsoil.
- B. Excavation of plant pits and beds.
- C. Backfill planting pits and bed preparation.
- D. Installation of new plant material.
- E. Finish grading of planting areas.
- F. Mulch and Fertilizer.
- G. Installation of Steel Edging.
- H. Maintenance.
- I. Tree Pruning.
- J. Warranty and Replacements

1.2 RELATED SECTIONS

- A. Section 32 92 23 – Sodding

1.3 REFERENCES

- A. ANSI Z60.1 - American Standard for Nursery Stock; 2004.
- B. ANSI A300 - American National Standard for Tree Care Operations -- Tree, Shrub and Other Woody Plant Maintenance -- Standard Practices; 2006.

1.4 DEFINITIONS

- A. Weeds: Any plant life not specified or scheduled.
- B. Plants: Living trees, plants, and ground cover specified in this Section.

1.5 SUBMITTALS

- A. See Division 1 - Administrative Requirements, for submittal procedures.
- B. Provide the following Material Samples and Literature:
 - 1. Photographic image of each variety and size of plant material shown on the plans and plant list and indicated in the specifications. Each image will include a clearly legible measuring device, plant common name, plant botanical name, and the supplier's name, location and phone number. Submit representative photographs for review of all plant materials in the required sizes and in available quantity at least ninety (90) working days prior to shipment to the site.
 - 2. Hardwood Mulch: One (1) gallon (sample) with analysis and literature including supplier's name, location and phone number.
 - 3. Soil Amendments: One (1) gallon (sample) with analysis and literature including supplier's name, location and phone number.
 - 4. Tree Staking/Guying: Literature for materials and shop drawings of installation details and procedures.
 - 5. Plant Material Supplier: Ordering Document, Order Confirmation. Submit documentation within thirty (30) days after Award of Contract that all plant materials have been located and are ready to be secured. Arrange specific review and/or tagging procedure of plant materials at time of submission.

6. **Shipping and Transportation Plan for distant material. The plan shall include:**
 1. Date of pick-up at nursery or place of storage.
 2. Type of vehicle used for shipping.
 3. Method of protecting trees during transit.
 4. Dates in transit.
 5. Date of delivery to site.
 6. Projected date of installation.
 7. Means of storage, watering and protection to be used between deliveries and installation.
 7. **Shop Drawings:** Supply shop drawings for all items associated with the landscape installation including, but not limited to; staking and guying details, tree protection fencing, steel edging installation, gravel paving, planter installation and drainage, landscape drain installation, etc.
- C. **Submittal Schedule:** All products in this section which are required for submittal shall be included in one (1) Division 2 submittal package.

1.6 QUALITY ASSURANCE

- A. **Quality Control:** Plant material shall be subject to inspection and approval by Landscape Architect at place of growth or storage and upon delivery for conformity to specifications.
- B. **Samples:** The Owner reserves the right to request samples of materials for conformity to specifications at any time, including plants. Contractor shall furnish samples upon request. Rejected materials shall be immediately removed from the site at Contractor's expense. Cost of samples of materials not meeting specifications shall be paid by Contractor.
- C. **Nursery Qualifications:** Company specializing in growing and cultivating the plants with three years documented experience.
- D. **Installer Qualifications:** Company with a minimum of five years experience in the installation of commercial landscaping and site construction.
- E. **Tree Care Qualifications:** Firm specializing in the pruning and care of trees. All work will be performed or directly supervised by a certified arborist. All work will be performed according to TCIA – Pruning Standards for Shade Trees. If the installation contractor does not employ a certified arborist, the work shall be sub-contracted to a firm that meets the qualifications.
- F. **Maintenance Services:** Performed by qualified professional maintenance contractor. All pesticide applications will be done by an applicator certified by the Texas Department of Agriculture or the Structural Pest Control Board. If the installation contractor does not employ a certified pesticide applicator or licensed irrigator, the work shall be sub-contracted to a firm that meets the qualifications.

1.7 TAGGING

- A. **Nursery review and plant selections:** The Landscape Architect may elect to review any of the material at the place of growth. Upon review and acceptance of plant material photograph, specific items will be selected for field review by the Landscape Architect. The Landscape Contractor shall arrange the review and accompany the Landscape Architect for all reviews and tagging at place of growth, and upon delivery, for conformity to the specifications. Contractor shall insure a

sufficient quantity of plants will be available whenever trips are arranged to a nursery for the purposes of tagging material for the project.

- B. Plants identified as "specimen" or "selected specimen" shall be approved and tagged at place of growth by Landscape Architect. For distant material, submit photographs with a clearly legible measuring device adjacent to plants for preliminary review. Such review shall not impair the right of review and rejection during progress of the work.
- C. Contractor is responsible for all travel related expenses for tagging trips necessary to select and procure material. Owner and Landscape Architect will accompany contractor, but travel expense for these individuals are not included in contractor's scope of work.
- D. All plants inspected at the nursery by the Landscape Architect shall be tagged with serialized self-locking tags. Trees delivered to the site without these tags or with broken tags shall be sufficient reason for rejection.

1.8 PHOTOGRAPHIC ACCEPTANCE

- A. Photograph Acceptance and Nursery Review: Acceptance of material through photographs does not preclude rejection of unsatisfactory material upon delivery. The Landscape Architect reserves the right to refuse review from photographs or at the grower if, in his judgment suitable material or sufficient quantities are not available.

1.9 SUBSTITUTIONS

- A. Unavailable Material: If any plant material is not available, the Contractor shall bring this to the attention of the Landscape Architect at least 3 days prior to the bid due date. If there is no notice of the lack of availability, it will be assumed that the Contractor has located sources for all materials required to complete the work. If proof is submitted that any plant specified is not obtainable, a proposal will be considered for use of the nearest equivalent size or variety with corresponding adjustment of Contract price. Substantiate such proof in writing no later than fifteen (15) days after award of contract.

Prior to selecting alternate material, the Landscape Architect may, at his discretion, attempt to locate the material. Should the specified plant material be located by the Landscape Architect for the Contractor, the Contractor shall secure the material from the new source at no change to the contract price.

- B. Substitutions of plant materials will not be permitted unless authorized in writing by Landscape Architect. If proof is submitted that any plant specified is not obtainable, a proposal will be considered for use of the nearest equivalent size or variety with corresponding adjustment of Contract Price. Such proof shall be substantiated and submitted in writing to Landscape Architect no later than fifteen (15) days after award of contract. These provisions shall not relieve Contractor of the responsibility of obtaining specified materials in advance if special growing conditions or other arrangements must be made in order to supply specified materials.

Prior to selecting alternate material, the Landscape Architect may, at his discretion, attempt to locate the material. Should the specified plant material be located by the Landscape Architect for the Contractor, the Contractor shall secure the material from the new source at no change to the contract price.

1.10 REGULATORY REQUIREMENTS

- A. Fertilizers, pesticides and other chemicals and materials required for the completion of the Work shall fully comply with city, county, state and federal regulatory agencies' requirements.
- B. Plant Materials: Described by ANSI Z60.1; free of disease or hazardous insects.

1.11 DELIVERY, STORAGE, AND HANDLING

- A. Deliver fertilizers, pesticides and other chemicals or materials in the manufacturer's original container. All labeling shall be attached and legible. Dry materials, such as fertilizer, will be delivered in waterproof bags showing weight, chemical analysis, and name of manufacturer.
- B. Labeling: All fertilizers, pesticides and other chemicals or materials shall include all of the manufacturer's original labeling legibly showing quantity, analysis and name of manufacturer.
Representative samples of all varieties of plant material required will be tagged with labeling showing the botanical name, common name, size and grower. Material delivered to the site without this labeling is subject to rejection. Rejected material will be removed for the site and replaced at the Contractor's expense.
- C. Storage: Store products with protection from weather or other conditions which would damage or impair the effectiveness of the product. Protect plant containers from sun during summer months with temperatures above 80 degrees F. During hot weather the Contractor shall transport plant materials subject to heat damage between sunset and sunrise if transported in an open trailer or un-refrigerated box.
- D. Loading and Moving: Do not lift or handle plants by tops, stems or trunks at any time. Do not bind or handle plants with any material or in any manner that could damage or disfigure the plant material at any time.
 - 1. Protect all trunks, stems, branches and root balls during tree tying, wrapping and loading operations.
 - 2. Load balls or containers onto transport vehicle and secure in a manner that protects the structural integrity of the root balls.
 - 3. The Contractor shall be solely responsible for the safe transportation of plants to the site and their condition upon arrival. Trees damaged or dehydrated during transit and/or storage will be rejected.
 - 4. No trees are to be shipped and left in trailers or on trucks for storage. Arrange delivery so that the plant materials are shipped, off loaded, and safely stored or planted allowing the appropriate time from shipment to arrival with no delay. Balled and burlapped trees that are not planted the day of delivery shall be set upright and healed in with mulch until they are installed.
 - 5. The Landscape Architect may inspect any phase of this operation and may reject any plant material improperly handled during any phase of this operation.
- E. Anti-Desiccant: At Contractor's option, spray all evergreen or deciduous plant material in full leaf immediately before transporting with anti-desiccant. Apply an adequate film over trunks, branches, twigs and foliage.
- F. This Section shall not be interpreted as relieving the Contractor of the responsibility of providing healthy, viable plants, nor shall it have any affect upon the terms of the warranty specified herein.

1.12 ENVIRONMENTAL REQUIREMENTS

- A. Do not install plant material when ambient temperatures may drop below 32 degrees F for more than 24 hours. Do not install plant material when temperatures over 100 degrees F without written direction from the Landscape Architect or Owner's Representative.
- B. Do not install plant material when wind velocity exceeds 30 mph.

1.13 ESTABLISHMENT PERIOD AND FINAL ACCEPTANCE

- A. See Section 32 01 90 – Landscape Maintenance until Final Acceptance & Landscape Establishment for Ninety (90) Days (if applicable)
- B. Final acceptance of the Work will mark the beginning of the ninety-day landscape establishment period.

1.14 FINAL ACCEPTANCE

- A. Work under this Section will be conditionally accepted by Landscape Architect upon satisfactory completion of all work and punch-list corrections, but exclusive landscape establishment period or replacement of plant materials under the Warranty Period. The Contractor is responsible for all maintenance of the work until Final Acceptance, and the during the ninety-day establishment period. Upon completion of the landscape establishment period, the Owner will assume responsibility for maintenance of the Work.

1.15 WARRANTY

- A. See Division 01 – General Requirements, for additional warranty requirements. (if applicable)
- B. Warranty: Warrant that all trees, shrubs, ground covers, and vines planted under this Contract will be healthy and in flourishing condition of active growth one (1) year from date of Final Acceptance. The Contractor shall be responsible for monitoring the condition of the landscape during the warranty period and for reporting any problems, in writing, to the Owner's Representative. Failure to report problems in a timely manner may make the Contractor responsible for the replacement of material damage from improper maintenance.
- C. Delays: All delays in completion of planting operations which extend the planting into more than one planting season shall extend the Warranty Period correspondingly. Delays due to water restrictions may extend the warranty period. Requests for changes to the warranty period will be made in writing to the Owner's Representative.
- D. Condition of Plants: Plants shall be free of dead or dying branches and branch tips, with all foliage of a normal density, size and color.
- E. Replace, without cost to Owner and as soon as weather conditions permit, all dead plants and all plants not in vigorous, thriving condition, as determined by the Owner or Owner's Representative during and at the end of Warranty Period. Plants shall be free of dead or dying branches and branch tips, and shall bear foliage of a normal density, size and color. Replacements shall meet the specifications of the original plant material, and closely match adjacent specimens of the same variety.
- F. Replacement Quantities:

1. A new Warranty shall commence on date of replacement.
 2. Contractor shall be held responsible for as many replacements as necessary throughout the Warranty Period. The Contractor may ask for an alternate plant material in problem locations. The alternate plant material will be installed under the original warranty.
- G. Contractor shall not be held responsible for failure due to neglect by the Owner, vandalism, etc., during Warranty Period. Report such conditions to the Landscape Architect in writing.

PART 2 PRODUCTS

2.1 TREES, PLANTS, VINES AND GROUND COVER

- A. Trees, Plants, and Ground Cover: Species and size identifiable in Plant Schedule in drawings.
- B. Unless otherwise noted in the specifications or plant list, all plants shall be nursery grown in accordance with good horticultural practices under climatic conditions similar to those of project for at least two years unless specifically otherwise authorized by Landscape Architect in writing. Unless specifically noted otherwise, all plants shall be exceptionally heavy, symmetrical, tightly knit, so trained or favored in development and appearance as to be superior in form, number of branches, compactness and symmetry.
- C. Plants shall be sound, healthy and vigorous, well branched and densely foliated when in leaf. They shall be free of disease, insect pests, eggs, or larvae, and shall have healthy, well developed root systems. They shall be free from physical damage or adverse conditions that would prevent thriving growth.
- D. Container grown native grasses and aquatics (non-woody plants) shall have well-established rootballs. Rootballs of non-woody plants must not be separated, broken up, or otherwise damage prior to or during installation.
- E. Plants shall be true to species and variety and shall conform to measurements specified except that plants larger than specified may be used if approved by Landscape Architect. Use of such plants shall not increase Contract price. If larger plants are approved, the ball of earth or container size shall be increased as specified under "Applicable Standards" and subject to the approval of the Landscape Architect.
- F. Plants shall be measured when branches are in their normal position. Height and spread dimensions specified refer to main body of plant and not branch tip to tip. Trunk caliper measurements shall be taken at a point on the trunk six (6") inches above natural ground line for trees four (4") inches in caliper and smaller, and at a point twelve (12") inches above the natural ground line for trees larger than four (4") inches in caliper. Caliper measurements shall be taken using a diameter tape, not calipers.

The measurements specified are the minimum size acceptable and are the measurements after pruning, where pruning is required. Plants that meet the measurements specified, but do not possess a normal balance between height and spread shall be rejected.

- G. Container stock, when specified, shall be healthy, vigorous, well rooted, and established in the container in which it is growing. Container grown nursery stock shall have a well-established root system reaching the sides of the container to maintain a firm root ball when the container is removed, but shall not have excessive root growth encircling the inside of the container. Samples must prove no root-bound conditions exist. Container plants that have cracked or broken balls of earth when taken from container shall be rejected. Container stock shall not be pruned before delivery. Field grown plants recently transplanted into containers will not be accepted. Unless specified as 'containerized', no balled and burlap trees transplanted into containers will be accepted.
- H. Trees which have damaged, crooked or multiple leaders, unless specified, will be rejected. Trees with abrasions of the bark, sunscalds, disfiguring knots, or fresh cuts of limbs over three-quarter (3/4") inch which have not completely calloused, will be rejected.
- I. Balled and burlap (B&B) trees, when accepted shall have a minimum root ball size of ten (10x) times the caliper.
- J. Nursery grown B&B material shall be pruned and thinned at the place of growth immediately prior to digging as required for packaging and safe moving. Trees that are over-pruned or misshapen due to improper pruning will be rejected. Method of pruning shall be as approved in the field by the Landscape Architect. Do not remove self-locking tags during this pruning prior to delivery to site.
- K. Field collected or plantation grown stock shall conform to the applicable standards.

2.2 ANTI-TRANSPIRANT

- A. Anti-transpirant for retarding excessive loss of plant moisture and inhibiting wilt shall be sprayable, water insoluble polymer complex which will produce a moisture retarding barrier not removable by rain.
- B. WILT PRUF as manufactured by Wilt Pruf Products, Inc., Essex CT; or accepted equal.

2.3 SOIL MATERIALS

- A. Topsoil: Type specified in Section 32 91 19
- C. Soil Amendment Materials
 - 1. Pre-Plant Fertilizer: Containing fifty percent of the elements derived from organic sources; of proportion necessary to eliminate any deficiencies of topsoil, as indicated in analysis.
 - 2. Compost: Completely organic, aerobically composted humus product containing manure, wheat straw, plant matter, hardwood shavings and other organic components consisting of 80% vegetative material and 20% manure. Completely composted; free of weeds, weed seeds, insects, and pests. pH range 6.5-7.0 Supplied by Living Earth Technology, 972-869-9498
 - 3. Professional Bedding Soil: Bedding mix shall consist of compost and expanded shale. Gumbo Buster supplied by Soil Building Systems or equal can be substituted. (50% Shale and 50% Planting Bedding Mix)

4. **Top-dress Fertilizer:** Per Organic Maintenance Specification
5. **Tree and Shrub Planting Fertilizer:** Per Organic Maintenance Specification.
6. **Water:** Clean, fresh, and free of substances or matter which could inhibit vigorous growth of plants. Watering for chemical tanks will not be allowed.
7. **Herbicide:** For pre-plant preparation, Reference Organic Maintenance Specification. For post-plant weed control, Reference Organic Maintenance Specification. Applications must be approved for use in the State of Texas and be applied by licensed applicators. The Owner and/or Owners' Representative must be notified at least 48 in advance of applications. A copy of the applicator's log must be supplied to the Owner's Representative within 48 of any chemical application.
8. **Pesticide:** Pesticides may be used for specific pest infestations, but only in limited application. Reference Organic Maintenance Specification. Applications must be approved for use in the State of Texas and be applied by licensed applicators. The Owner and/or Owners' Representative must be notified at least 48 in advance of pesticide applications. A copy of the applicator's log must be supplied to the Owner's Representative within 48 of any chemical application.

2.4 MULCH MATERIALS

- A. **Mulching Material:** Fine-ground shredded hardwood bark mulch – Double-ground, partially composted, and free of growth or germination inhibiting ingredients. pH range 6.0-7.0 Supplied by Living Earth Technology, 972-869-4332

2.5 ACCESSORIES

- A. **Plant Staking Materials:** Contractor shall use staking materials as necessary to meet the requirements of the specification, subject to approval. Refer to details for staking and/or guying requirements.
 1. **Tree Stakes:** 1.25# studded metal T-Posts - 6' long.
 2. **Wire:** High-tensile 12 gauge; 200,000 psi; Class III zinc coating. Refer to details.
 3. **Cable:** 3/16" galvanized or stainless steel aircraft cable; 7x19; min. 4,200 psi break strength; secured with drop-forged galvanized clips
 4. **Turnbuckles:** Minimum 1/2"x6", hot-dipped galvanized or stainless steel, eye and eye.
 5. **Ground Anchors:** 30"x4" dia. galvanized ground screw for 3"-4" caliper trees, 48"x6" dia. for trees 5"-6" caliper.
 6. **Plant Protectors:** Reinforced black rubber hose sleeves over cable to protect plant stems, trunks, and branches. Tubing or thin-wall hose will not be accepted.
- B. **Filter Fabric:** Mirafi 140N as manufactured by Mirafi Construction Products, Pendergrass, GA.
- C. **Steel Edging:** 3/16" x 4" electrostatically applied, powder-coat painted steel as manufactured by the J.D. Russell Co., 1-800-888-6872
- D. **Drainage Gravel:** 5/8" to 1", smooth, washed gravel.

PART 3 EXECUTION

3.1 EXAMINATION

- A. Verify that prepared subsoil, planters, on-structure decks, etc. are ready to receive work. The Contractor assumes all responsibility for the correction of work installed on improper grades.
- B. Verify that required underground utilities are available, in proper location, and ready for use.
- C. Finish Grades: Verify that all grades are within one (1") inch, plus or minus, of required finish grade and that all topsoil has been installed (if applicable) as specified under Landscape Grading - Section 32 91 19
- D. Notification: Submit written notification of all conditions inconsistent with specifications for site grading as described in Landscape Grading - Section 32 91 19

3.2 DRAINAGE OF PLANTING AREAS

- A. Surface Drainage: Maintain positive surface drainage of planted areas as established under Landscape Grading - Section 32 91 19.
- B. Discrepancies: Contractor shall bear final responsibility for proper surface drainage of planted areas. Submit in writing, all discrepancies in the Drawings or Specifications, obstructions on the site, or prior work done by others, which Contractor feels precludes maintaining proper drainage. Include description of all work required for correction or relief of said responsibility.

3.3 DRAINAGE, DETRIMENTAL SOILS AND OBSTRUCTIONS

- A. Test drainage of plant beds and pits by filling with water twice in succession. Conditions permitting the retention of water in planting beds for more than twenty four (24) hours or percolation of less than one (1") inch per hour shall be brought to the attention of the Owner.
- B. Notify the Landscape Architect in writing of all soil or drainage conditions Contractor considers detrimental to growth of plant material.
- C. Obstructions: If rock, underground construction work, tree roots or other obstructions are encountered in the excavation of plant pits, alternate locations may be used as directed. Where locations cannot be changed, submit for acceptance a written proposal and cost estimate for cost required to remove the obstructions to a depth of not less than six (6") inches below the required pit depth. Proceed with work after written acceptance.

3.4 PREPARATION OF SUBSOIL

- A. Prepare subsoil to eliminate uneven areas. Maintain profiles and contours. Make changes in grade gradual. Blend slopes into level areas.
- B. Remove foreign materials, weeds and undesirable plants and their roots. Remove contaminated subsoil.
- C. Scarify subsoil to a depth of 6 inches where plants are to be placed. Repeat cultivation in areas where equipment, used for hauling and spreading topsoil, has compacted subsoil.

- D. Excavate planting pits and beds to the dimensions as shown on Detail Drawings, not less than two times the width of the rootball and slightly less than the depth of the rootball. Do not place trees on uncompacted backfill. If tree pits are excavated too deeply, add soil excavated from the tree pit and compact.

3.5 LAYOUT OF PLANTING AREAS

- A. **Layout and Staking:** Lay out plants at locations shown on Drawings. Use color-coded wire flags for each species of plant material. Stake the location of each tree, vine and major shrub. Outline shrub and groundcover masses and bed edges with marking paint.
- B. Locations of plants will be observed in the field by the Landscape Architect and will be adjusted to exact position before planting begins. Right is reserved to refuse review at this time if, in the Landscape Architect's opinion, a sufficient quantity of plants is not available. The Contractor shall be responsible for moving any plant material if layout was not approved by the Landscape Architect prior to planting.

3.6 STEEL EDGING

- A. **General:** Install edging prior to installation of adjacent sprinkler irrigation system.
- B. **Edging:** Install headers true to line and grade as shown on the Drawings. Align edging and set flush with adjacent paving. Curved edges shall be smooth and continuous with no flat areas or abrupt bends. Straight segments will be string-line-straight with no bows or bends.
- C. **Stakes:** Stakes shall be a minimum of twelve (12") inches long and longer as required for solid anchorage. Anchor with steel stakes spaced not more than three (3") feet o/c or as often as necessary to have smooth radius or straight tangent. Drive stake to one (1") inch below top of edging.

3.7 PLANTING OPERATIONS

- A. **General:**
 - 1. Protect plants at all times from sun or drying winds.
 - 2. Keep plants that cannot be planted immediately upon delivery in the shade, well-protected and well-watered.
- B. Do not bind or handle any plant with wire or rope at any time so as to damage bark or break branches. Lift and handle plants only from bottom of ball. Improperly handled plant material is subject to rejection.
- C. Ball and burlap (B&B) plants shall have firm balls of earth of a size to encompass enough of the fibrous and feeding root system as necessary for the complete recovery of the plant. At a minimum, rootballs should be size per the American Standard for Nursery Stock (ANSI Z60.1-2004). Any plants with a rootball that is undersized, cracked or broken, before or during planting operations will not be accepted. B&B material shall be dug only when dormant. Pre-dug and stored B&B material shall be inspected and approved at the storage site. B&B trees with chicken wire or other wire mesh around the rootballs will not be accepted.
- D. At Contractor's option and expense, spray all evergreen or deciduous plant material in full leaf immediately before digging with anti-desiccant, applying an adequate film over trunks, branches, twigs, and foliage.

3.8 SOIL PREPARATION

A. **General:** Verify that prepared subsoil, planters, on-structure decks, etc. are ready to receive work. The Contractor assumes all responsibility for the correction of work installed on improper grades.

B. **Tree Pit Preparation:**

1. **Excavation:** Excavate planting pits and beds to the dimensions as shown on Detail Drawings, not less than two times the width of the rootball and slightly less than the depth of the rootball. Do not place trees on uncompacted backfill. If tree pits are excavated too deeply, add soil excavated from the tree pit and compact so that the top of root ball will be at 1"-2" above finished grade after settling.

Scarify the walls and bottom of all plant pits immediately prior to the placement of plant and backfill mix. The Contractor shall remove all glazing caused by an auger or other mechanical excavation equipment.

2. **Tree Backfill Mix:** Use native soil excavated from the tree pit. If the pit is excavated in rock, do not backfill with excavated material. Instead, use backfill with topsoil from on-site stockpile or import soil of a type similar to the existing site soil. Excess material is to be used for fine grading or lawfully disposed of at an off-site location depending on site grade conditions.
3. **Ornamental Tree Pit Backfill:** Mix soil excavated from the pits mixed with Professional Bedding Soil in a 5:1 ratio. If the pit is excavated rock, do not use excavated material as backfill. Instead, use topsoil from on-site stockpile or import soil of a type similar to the existing site soil. Mix in the same 5:1 ratio with Professional Bedding Soil. Excess tree pit spoil material is to be used for fine grading, if needed depending on site grade conditions, or lawfully disposed of at an off-site location at the Contractor's expense.

C. **Bed Preparation:**

1. Smooth planted areas to conform to specified grades after full settlement has occurred. Contractor shall bear final responsibility for proper surface drainage of planted areas. Any discrepancy in the drawings or specifications, obstructions on the site, or prior work done by another party which Contractor feels precludes establishing proper drainage, shall be brought to the attention of the Landscape Architect in writing prior to any work being started.
2. Till subsoil to a depth of 6 inches where plants are to be placed. In areas where equipment or vehicular traffic has compacted subsoil, rip or scarify the sub-grade to a depth of 12" prior to tilling.
3. Uniformly spread 3 inches of compost and 3 inches of expanded shale in all bed areas and till into existing soil to a depth of 12". In seasonal color beds, use 4" of Professional Bedding Soil

3.9 TREE AND SPECIMEN SHRUB PLANTING

A. Container stock shall be removed carefully without pulling on the trunk or stem. If required, cut can on two sides with approved cutter. Do not use spade to cut cans. Do not lift or handle container plants by trunk at any time. Prune away girdled roots and gently loosen root masses.

- B. For boxed material, break vertical bands and remove top and bottom of container. Carefully lower plant into pit, by approved method, and adjust elevation. Cut horizontal bands and remove sides. Prune away girdled roots and gently loosen root masses.
- C. Place B&B plants carefully in the prepared planting pit and adjust elevation. Backfill tree pit approximately 50%. Tamp soil and set tree plumb. Remove top 1/3 of the basket and burlap. Add and tamp the remainder of the backfill.
- D. Place bare root plant materials so roots lie in a natural position. Backfill with soil mixture in 6 inch lifts. Maintain plant in vertical position.
- E. Set plants plumb and orient for best appearance for review and final orientation by Landscape Architect, if requested.
- F. Carefully fill pits and compact by watering and tamping each eight (8") inches of backfill to support root ball.
- G. Fertilizer: Place evenly distributed in plant pits when backfilled 2/3 according to the organic maintenance specification.
- H. Adjustment: Adjust trees so that, after full settlement has occurred, the natural grade at the base of the trees is 1"-2" inches above the adjacent finish grade.
- I. Smooth surrounding areas to conform to specified grades after full settlement has occurred. Contractor shall bear final responsibility for proper surface drainage of planted areas. Any discrepancy in the drawings or specifications, obstructions on the site, or prior work done by another party which Contractor feels precludes establishing proper drainage, shall be brought to the attention of the Landscape Architect in writing.
- J. Watering Basin: Form circular ring of earth to create a three (3") inch high berm with tree or specimen shrub in the center. The inside diameter of the basin shall be equal to the diameter of the rootball.
- K. Water all trees immediately again after planting.
- L. Apply pre-emergent weed control material in areas to receive mulch.
- M. Spread mulch in watering basins to the depth of three (3") inches.
- N. Remove all flagging, tags, plastic ties, wire, string, cord or any other material that may damage the bark. DO NOT remove Landscape Architect's lock-rings or plant identification tags until instructed by the Landscape Architect.

3.9 SHRUB AND GROUNDCOVER PLANTING

- A. Tilling: Immediately prior to planting, re-till bed areas to be planted with groundcover, perennials or seasonal color.
- B. Planting: Set plant material so that the top of the rootball is slightly above the surrounding grade. Avoid air pockets. Equally space as directed by the details or plant list. Refer to details for plant mass or bed edge planting.
- C. Fertilizer: Apply topdressing fertilizer to all groundcover, perennial and seasonal color beds. Backfill all shrub pits ½ and add fertilizer per organic specifications.

- D. Smooth surrounding areas to conform to specified grades after full settlement has occurred. Contractor shall bear final responsibility for proper surface drainage of planted areas. Any discrepancy in the drawings or specifications, obstructions on the site, or prior work done by another party which Contractor feels precludes establishing proper drainage, shall be brought to the attention of the Landscape Architect in writing.
- E. Water all plant material immediately again after planting.
- F. Apply pre-emergent weed control material in areas to receive mulch.
- G. Spread mulch in bed areas to the depth of two (3") inches. Keep mulch away from plant stems.

3.10 AQUATIC PLANTING

- A. Staking: All aquatics to receive a minimum of one 3/8" re-bar pin. The pin shall be bent into an 'L' shape with the long leg 12" in length and the short leg 3" in length. Push pin through rootball into sides or bottom of planting pit so that it is flush with the top of rootball.
- B. The following are planting requirements for various non-woody aquatics:
 - 1. Install aquatics when lakes are drained down (well turned off) below planting shelf. Planting areas to be moist but not flooded or saturated (boggy).
 - 2. Install at soil surface, but NOT above soil surface. Be sure crowns are fully covered and not washed out.
 - 3. Ensure there is full contact, with no air or water pockets, between rootball and surrounding soil. Water in.
 - 4. Install stakes as specified above.
 - 5. Maintain NON-flooded condition for minimum of three days after installation prior to restoring flooded condition.

3.12 PLANT SUPPORT

- A. Trees that are not capable of standing upright without falling or leaning shall be staked or guyed. The Contractor is responsible for material remaining plumb and straight for all given conditions through the guarantee period. Tree support shall be performed as outlined below.
- B. Staking shall be completed immediately after planting. Plants shall stand plumb after staking.
- C. Brace plants vertically with plant protector wrapped guy wires and stakes to the following:
 - 1. For trees 3" caliper and less, use two (2) steel T posts. Orient stakes, generally, one to the south of the trunk, and one to the north. Install a loop of wire from the trunk just above the lowest branches (or level with the top of the T post for plants that are full-to-the-ground) to the top of the T post. Provide hose to protect the bark of the tree. Twist the two strands of wire until slightly less than taut. DO NOT OVER-TIGHTEN. Trees should be free to move in light breezes.
 - 2. For trees larger than 3" caliper and less than 6" caliper, use three (3) steel T posts. Orient stakes, generally, two to the south of the trunk and one to the north, equally spaced. Install a loop of wire from the trunk just above the lowest branches (or level with the top of the T post for plants that are full-to-the-

ground) to the top of the T post. Provide hose to protect the bark of the tree. Twist the two strands of wire until slightly less than taut. **DO NOT OVER-TIGHTEN.** Trees should be free to move in light breezes.

3. For trees 6" caliper and larger, use three (3) guy wires. Install three (3) ground-screw anchors oriented, generally, two to the south of the trunk, and one to the north, equally spaced. Run aircraft cable through the eye on the anchor and secure with two cable clips. Loop the other end of the cable through one eye of a turnbuckle and secure with two cable clips. Install a loop of aircraft cable, with hose to protect the bark, around the trunk just above the lowest branches and secure with two cable clips. Loop the other end of the cable through the second eye of the turnbuckle, pull tight and secure with cable clips. Remove any slack by tightening the turnbuckle. **DO NOT OVER-TIGHTEN.** The trees should be free to move in light breezes.

- D. Locate stakes as per Drawing Details outside rootball and as close to the main trunk as is practical, avoiding root injury. Stakes shall be driven at least eighteen (18") inches into firm ground. Stake shall be straight and plumb. **DO NOT** install stakes at an angle.

Typically, stakes and guys will be oriented south to north or per local prevailing winds. Verify with Landscape Architect before installing stakes or guys. Site conditions may necessitate a different configuration.

- E. Auxiliary stem stakes shipped with trees shall be removed after planting.

3.13 TREE PRUNING

- A. Perform pruning of trees as recommended in ANSI A300.
- B. Prune newly planted trees as required to remove deadwood, suckers, broken, and split branches. **DO NOT** head-back any trees or remove lower branches.
- C. Prune B&B material, as may be directed by Landscape Architect, by removing a percentage of interior branching proportional to the root loss during digging (no more than 1/3).
- D. Use only clean, sharp tools.

3.14 CLEAN-UP

- A. Keep all areas of work clean, neat and orderly at all times. Clean walks and drive and remove trash daily.
- B. Clean up and remove all materials and debris from the entire site prior to Final Acceptance.

3.15 INSPECTIONS

- A. Perform field inspection and testing in accordance with Town of Addison Requirements
- B. Plants will be rejected if a ball of earth surrounding roots has been disturbed or damaged prior to or during planting.
- C. Make written request for inspections after planting operations are completed.

- D. Submit requests for progress inspections to the Owner at least two (2) days prior to anticipated inspection date.

END OF SECTION



Specifications for Electrical Underground Distribution Systems from Padmounted Transformation, Secondary Service Accounts

Specification DDS-4 UG
Revision 11, March 2010

**ONCOR ELECTRIC DELIVERY COMPANY
SPECIFICATIONS FOR ELECTRICAL UNDERGROUND DISTRIBUTION SYSTEMS
FROM PADMOUNTED TRANSFORMATION, SECONDARY SERVICE ACCOUNTS
SPECIFICATION NUMBER DDS-4 UG**

TABLE OF CONTENTS

SECTION 1- SCOPE	Page 1
SECTION 2- REFERENCES	Page 1
SECTION 3- DEFINITIONS	Page 1
SECTION 4- GENERAL	Page 1
SECTION 5- COMPANY RESPONSIBILITY	Page 2
SECTION 6- CONTRACTOR RESPONSIBILITY	Page 3
SECTION 7- ACCEPTANCE	Page 6

ATTACHMENTS:

DDS-4 UG Detail Sheets 1- 57

**ONCOR ELECTRIC DELIVERY COMPANY
SPECIFICATIONS FOR ELECTRICAL UNDERGROUND DISTRIBUTION SYSTEMS
FROM PADMOUNTED TRANSFORMATION, SECONDARY SERVICE ACCOUNTS
SPECIFICATION NUMBER DDS-4 UG**

1. SCOPE

This document represents the minimum requirements and specifications for the installation of the electrical underground distribution systems fed from padmounted transformation, serving Secondary Service Accounts, to be transferred to Oncor Electric Delivery Company ownership.

2. REFERENCES

This specification shall be used in conjunction with the latest edition of the following publications.

- 2.1 The Electric Service Guidelines, Oncor Electric Delivery Company.

3. DEFINITIONS

- 3.1 Company: Oncor Electric Delivery Company and its designated representatives.
- 3.2 Contractor: Individual or firm installing electric underground service to Secondary Service Accounts.
- 3.3 Authority Having Jurisdiction: Generally an incorporated City or Town, but may be an agency of the County, State or Federal Government.
- 3.4 Point of Delivery: The point where Company's conductors are connected to premise's conductors, typically at the padmounted transformer secondary terminals or the padmounted connection enclosure.

4. GENERAL

- 4.1 The latest edition of all applicable building and safety codes shall be followed in the installation of the electrical underground distribution system. Included, but not limited to, are the:

4. GENERAL (continued)

- 4.1.1 Local City Building and Fire Codes or any other applicable Codes for a particular project location
- 4.1.2 National Electrical Safety Code (NESC)
- 4.1.3 U.S. Occupational Safety and Health Act of 1970 (OSHA)
- 4.1.4 The American Concrete Institute (ACI)
- 4.1.5 The American Society for Testing and Materials (ASTM)
- 4.2 Upon receipt of all necessary information from the Contractor, a project sketch showing the route of the conduit line and other pertinent information will be furnished by the Company.
- 4.3 Prior to construction a meeting shall be held to discuss and coordinate construction and inspection.
- 4.4 The Company will require a signed easement at no cost or a filed plat incorporating Company easement requirements prior to the Company installing any electrical facilities.
- 4.5 Joint use ditch will be determined by the Company on an individual basis.
- 4.6 No electrical facilities shall be connected by the Company until after the final inspection is made and approval by the Authority Having Jurisdiction, as required by code, has been received.

5. COMPANY RESPONSIBILITY- The following shall be performed by, and the responsibility of, the Company:

- 5.1 The Company inspector is to inspect all conduit installations prior to the placing of backfill.
- 5.2 The Company inspector is responsible for all field changes and coordinates changes with the local Engineering office.
- 5.3 The Company inspector is to inspect all equipment pad installations prior to the laying of concrete.

5. COMPANY RESPONSIBILITY (continued)

- 5.4 After approval of the installed conduit system by the Company inspector, and after the Contractor has signed all appropriate contracts, agreements, easements and has paid any required CIAC (contribution in aid of construction), the Company shall install service lateral cables up to the line side of the point of delivery.
- 5.5 Upon notification of final electrical inspection from the Authority Having Jurisdiction, the Company is to make final electrical connections at the point of delivery.

6. CONTRACTOR RESPONSIBILITY- The following shall be performed by, and the responsibility of, the Contractor:

- 6.1 The Contractor is to provide the Company a Site Plan, a Dimension Control Plan, an Elevation Plan, a Grading Plan and loading information.
- 6.2 The Contractor is to coordinate with the Company inspector for inspection of work prior to backfilling.
- 6.3 The Contractor is to provide personnel and vehicular access to the facility at all times.
- 6.4 The Contractor is to be held responsible for the full direction and supervision of all work being performed by his employees, agents or contractors. The Contractor shall also be responsible for the area at all times prior to acceptance, particularly in the prevention of damage to the electrical distribution system by the activities of other trades and utilities.
- 6.5 All testing of concrete and backfill which is deemed necessary by the Company is to be performed by an independent testing laboratory at the Contractor's expense.
- 6.6 The Contractor is to replace at his expense any damaged equipment or work not in compliance with the requirements in these specifications, the project sketch, the DDS-4 UG Detail Sheets or as specified by the Company.
- 6.7 The Contractor is to furnish equipment and labor to lay out ditch, set grade, dig ditches, place conduit in ditch, set equipment pads and place electrical connection boxes. The line shall run in as straight alignment as practicable. All conduit and bends shall be Schedule 40 PVC or Schedule 80 PVC and shall be electrical grade. All PVC conduit and bends shall be gray in color.
- 6.8 The Contractor may be required to furnish a spare conduit in the same ditch with service conduit(s) and cap both ends at bends.

6. CONTRACTOR RESPONSIBILITY (continued)

- 6.9** The Contractor is to complete rough site grading, establish final grade at padmounted equipment locations and clear these locations of all obstructions. Any change in final grade which requires the lowering or raising of electrical conductors or associated equipment is at the expense of the Contractor.
- 6.10** Minimum vertical crossing clearance of electrical conduits from other utilities' conduits is twelve (12) inches.
- 6.11** A lateral separation of five (5) feet from electrical conduits to other utilities' conduits is required on private property.
- 6.12** No foreign pipes are permitted under the equipment pad area except gas, telephone and cable T.V. that are installed at the same time as the electrical facilities. Gas is allowed only if sleeved in polyethylene or Schedule 40 PVC. Telephone and cable T.V. are allowed only if installed in conduit.
- 6.13** Backfilling of conduit trenches under paved areas, around conduit bends and under transformer pad areas is to be compacted to 95% of the density of surrounding undisturbed soil as per ASTM D 698. Stabilization must be uniform to bottom of ditch. Alternative stabilization methods for backfilling around under transformer pad consist of two (2) sacks of cement mixed with earth backfill or the pouring of concrete backfill with transformer pad. An alternative method for backfilling around conduit bends consists of concrete backfill with bend. The method and location where used will be at the discretion of the Company.
- 6.14** Equipment pads are to be installed a minimum of three (3) inches above finished grade. No equipment pad shall be installed in a pit below the finished grade of the surrounding area.
- 6.15** Equipment pads are to have a clear area surrounding the pad installation for safety, operation and maintenance purposes. Refer to DDS-4 UG Detail Sheets 51, 52, 53 and 54 for layout and dimensions.
- 6.16** Piers and/or beams are required on all equipment pads unless waived by the Company inspector. If required, stabilization method(s) will be determined by the Company inspector. The depth shall extend to rock or a change in soil conditions sufficient to bear the load of pad and transformer to prevent settlement due to undercutting for conduit bend installation or washing due to drainage.
- 6.17** The Contractor has the option of installing manufactured transformer pads or poured in place pads. However, where terrain will not permit the installation of a manufactured equipment pad as determined by the Company, the Contractor is to install a poured in place equipment pad. For details, refer to the DDS-4 UG Detail Sheets.

6. CONTRACTOR RESPONSIBILITY (continued)

- 6.18 Concrete forms are to be tight and aligned so when forms are removed the finished surface shall require little, if any, corrective measures. Concrete work is to have an acceptable finish free of honeycombs, sharp or irregular surfaces.
- 6.19 Contractor is to pull a mandrel through each conduit to check and clear blockage and leave an approved pull tape in each conduit. Pull tape shall be furnished by the party providing conduit and shall be installed by Contractor. Mandrel shall be furnished by Contractor. Conduit shall be plugged at both ends. Reference DDS-4 UG Detail Sheet 7 for approved pull tapes.
- 6.20 Approved self-contained meter sockets or approved meter packs are to be provided and installed by the Contractor. Transocket meter bases and service enclosures (when required) are to be provided by the Company and installed by the Contractor. Reference the Electric Service Guidelines for approved self-contained meter sockets. **Contact Company for approval of meter packs prior to letting bids and installing equipment.**
- 6.21 For single occupant, C. T. metered Secondary Service accounts fed from padmounted transformation, the Contractor is to provide, install and maintain the underground raceway(s) and conductors to the secondary terminals of the transformer. The Contractor shall provide compression type connectors and the Company shall install these connectors on the Contractor's conductors and connect to the secondary terminals of the transformer. The meter will be located at or on the transformer secondary terminal enclosure. Reference the Electric Service Guidelines for approved compression type connectors.
- 6.22 In cases where the number of service conductors to a padmounted transformer is in excess of the physical connection capabilities of the secondary terminals, a padmounted connection enclosure separate from the transformer shall be used. The Contractor is to (1) provide, install and maintain the underground raceways and conductors to the load side of the connection enclosure, and (2) provide and install the underground raceways between the connection enclosure and the transformer pad. The service lateral conductors between the transformer secondary terminals and the source side of the connection enclosure shall be supplied, installed, connected and maintained by the Company. The Contractor shall provide compression type connectors and the Company shall install these connectors on the Contractor's conductors and connect to the load side of the connection enclosure. Reference the Electric Service Guidelines for approved compression type connectors.

6. CONTRACTOR RESPONSIBILITY (continued)

- 6.23** If socket type metering fed from padmounted transformation is utilized, the Contractor is to mount the meter socket on the building(s) with the location approved by the Company and provide, install and maintain the underground raceway(s) and conductors to the transformer secondary terminals. The Contractor shall provide compression type connectors and the Company shall install these connectors on the Contractor's conductors and connect to the secondary terminals of the transformer. Reference the Electric Service Guidelines for approved compression type connectors.
- 6.24** For multiple occupancy Secondary Service accounts fed from padmounted transformation, the Contractor is to provide, install and maintain (1) the conductors and associated raceways from the service enclosure to the padmounted transformer and (2) the conductors and associated raceways from the service enclosure to the line side of the meters. The Contractor shall provide compression type connectors and the Company shall connect the Contractor's conductors to the secondary terminals of the transformer. Reference the Electric Service Guidelines for approved compression type connectors.
- 6.25** For multiple occupancy Secondary Service accounts utilizing meter packs fed from padmounted transformation, the Contractor is to provide, install and maintain the conductors and associated raceways from the meter pack enclosure to the padmounted transformer. The Contractor shall provide compression type connectors and the Company shall connect the Contractor's conductors to the secondary terminals of the transformer. Reference the Electric Service Guidelines for approved compression type connectors.
- 6.26** The Contractor is to secure inspection and approval of premise's facilities by the Authority Having Jurisdiction prior to the connection of electrical facilities.
- 6.27** Meter sockets to multi-metered locations shall be clearly and permanently marked by Contractor on the exterior and interior of the meter socket to indicate each location served. Engraved or stamped metal, weather resistant placards shall be used on the exterior of the meter socket and be permanently affixed. Permanent marker or other acceptable method shall be used to mark the location on the inside of the meter socket (at a location other than the cover) where it can be easily read.

7. ACCEPTANCE

- 7.1** The Company inspector shall meet with the Contractor and review the project prior to acceptance. Electrical facilities will be installed as approved by the Company inspector only after acceptance of the project.

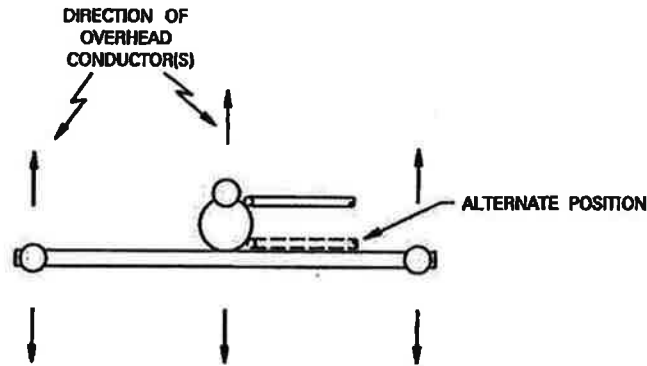

TOP VIEW

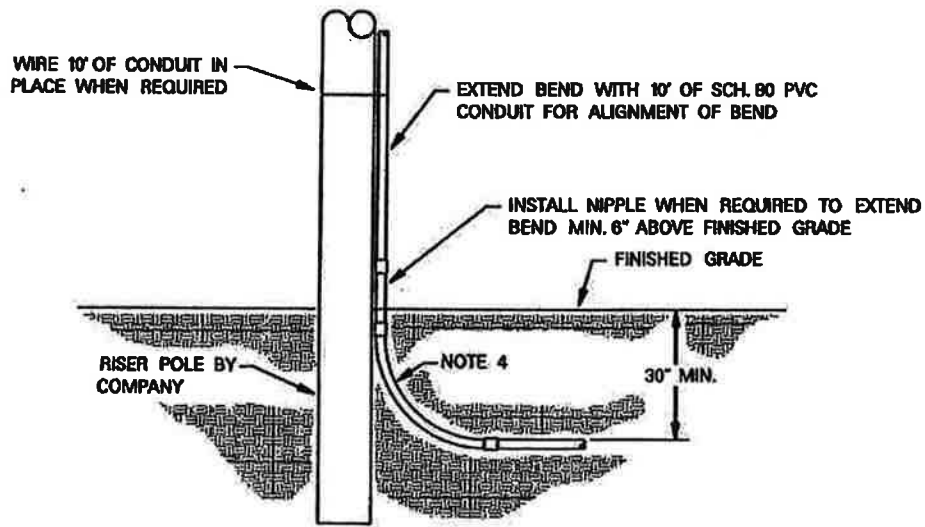

PLAN VIEW

NOTES

1. CONTACT COMPANY REPRESENTATIVE FOR (1) ROUTING OF CONDUIT LINE, (2) SIZE OF CONDUIT, AND (3) INSTALLATIONS REQUIRING MORE THAN ONE RISER ON POLE.
2. LIMIT RACEWAY TO THREE 90° BENDS. IF MORE THAN THREE 90° BENDS ARE REQUIRED, CONTACT COMPANY REPRESENTATIVE.
3. DISTANCE BETWEEN 90° BENDS SHALL BE FIVE FEET MINIMUM.
4. REFERENCE DETAIL SHEET 12 FOR BEND RADIUS FOR ALL HORIZONTAL AND VERTICAL CONDUIT BENDS.



**TERMINATION OF
PRIMARY CONDUIT
AT RISER POLE**

DDS-4 UG DETAIL SHEET 1 OF 57

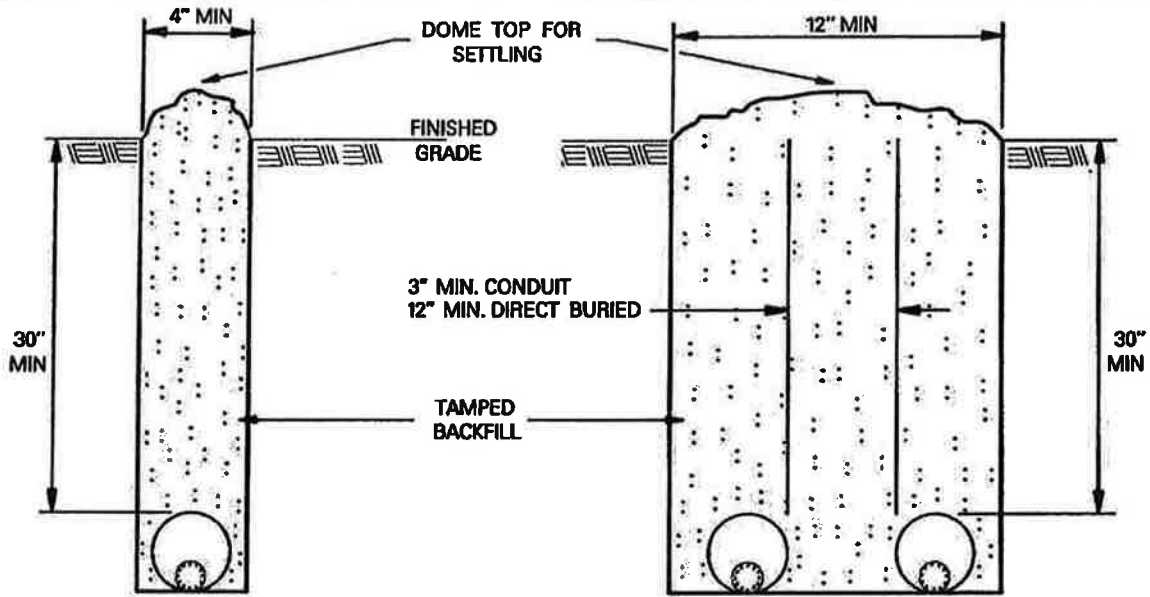

1 PRIMARY CONDUIT

2 PRIMARY CONDUITS

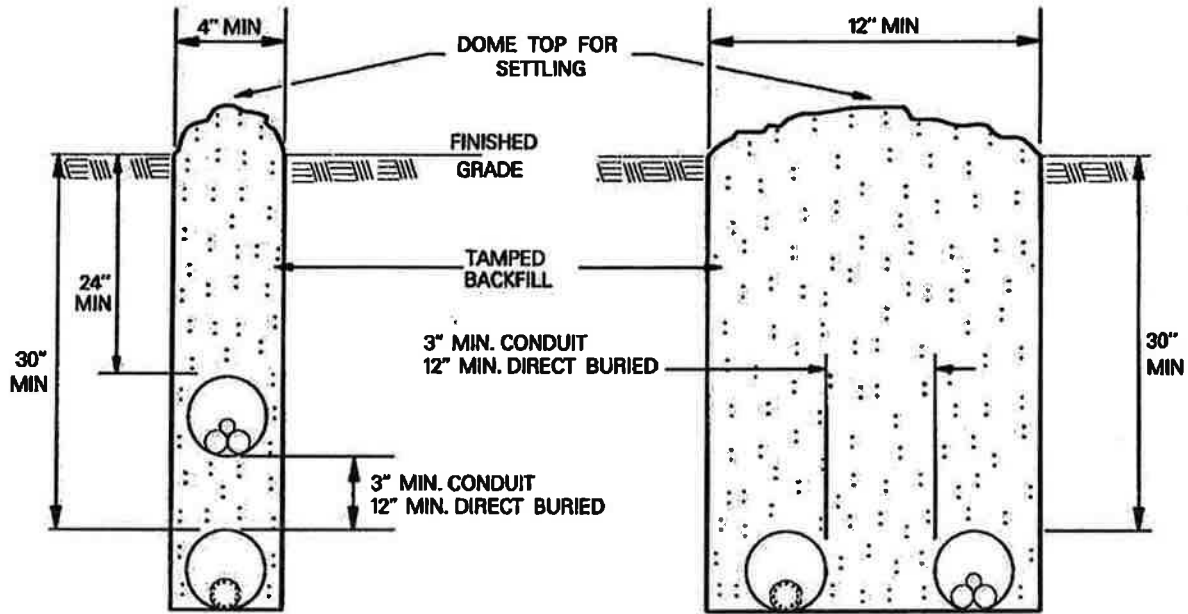

1 PRIMARY CONDUIT AND
 1 SECONDARY CONDUIT
 VERTICALLY ARRANGED

1 PRIMARY CONDUIT AND
 1 SECONDARY CONDUIT
 HORIZONTALLY ARRANGED

NOTES:

1. CONSULT COMPANY REPRESENTATIVE FOR CONDUIT SIZE.
2. SEE DETAIL SHEETS 7 AND 8 FOR NOTES AND INSTRUCTIONS.
3. SEPARATION DIMENSIONS APPLY TO COMPANY CONDUITS OR CABLES ONLY. MAINTAIN 12" SEPARATION BETWEEN COMPANY CONDUITS OR CABLES AND FOREIGN CONDUITS OR CABLES.



TRENCH REQUIREMENTS

DDS-4 UG DETAIL SHEET 2 OF 57

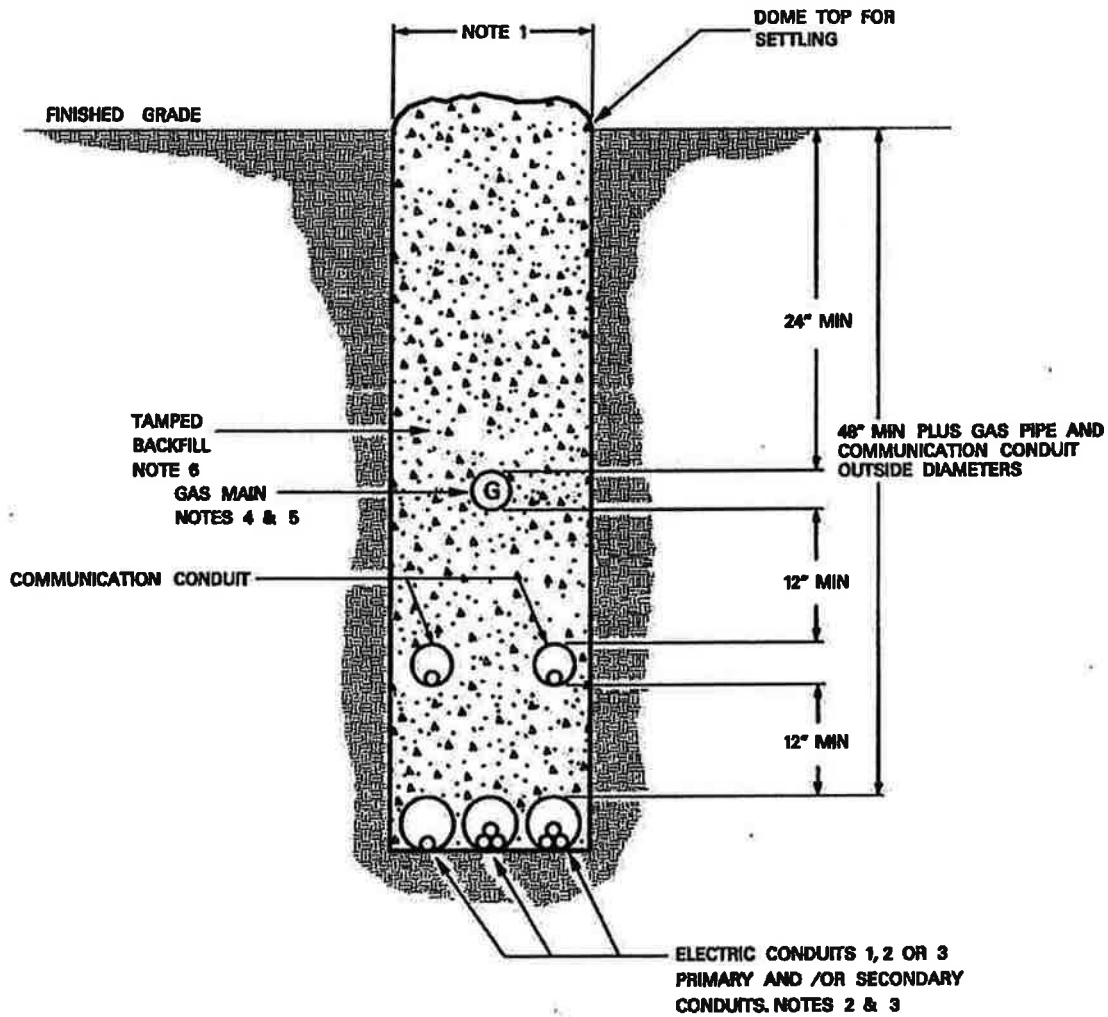

NOTES:

1. 12" MIN. WITH MORE THAN ONE ELECTRICAL SUPPLY CONDUIT.
4" MIN. WITH ONE ELECTRICAL SUPPLY CONDUIT (IN SOLID ROCK PIPE DIAMETER DETERMINES MIN. WIDTH).
2. AMPACITIES ARE REDUCED FOR MULTIPLE CIRCUITS IN A TRENCH.
3. SEE DETAIL SHEETS 7 AND 8 FOR NOTES AND INSTRUCTIONS.
4. THE GAS LINE IN A JOINT TRENCH SHALL BE POLYETHYLENE.
5. WHEN A GAS LINE CROSSES UNDER AN ENCLOSURE SUCH AS A PEDESTAL, PADMOUNT TRANSFORMER OR SPLICE/PULL BOX, IT WILL BE SLEEVED IN A SECTION OF POLYETHYLENE OR SCHEDULE 40 PVC. THE SLEEVE WILL EXTEND A MINIMUM OF THREE FEET BEYOND THE EDGE OF THE ENCLOSURE ON EACH SIDE. MAINTAIN A 12" SEPARATION BETWEEN GAS LINE AND ELECTRICAL SUPPLY CONDUIT(S).
6. BACKFILL MATERIAL AND COMPACTION SHALL MEET OR EXCEED EACH UTILITY'S SPECIFICATIONS.



**TRENCH REQUIREMENTS
JOINT USE ELECTRIC, GAS
AND COMMUNICATION**

DDS-4 UG DETAIL SHEET 3 OF 57

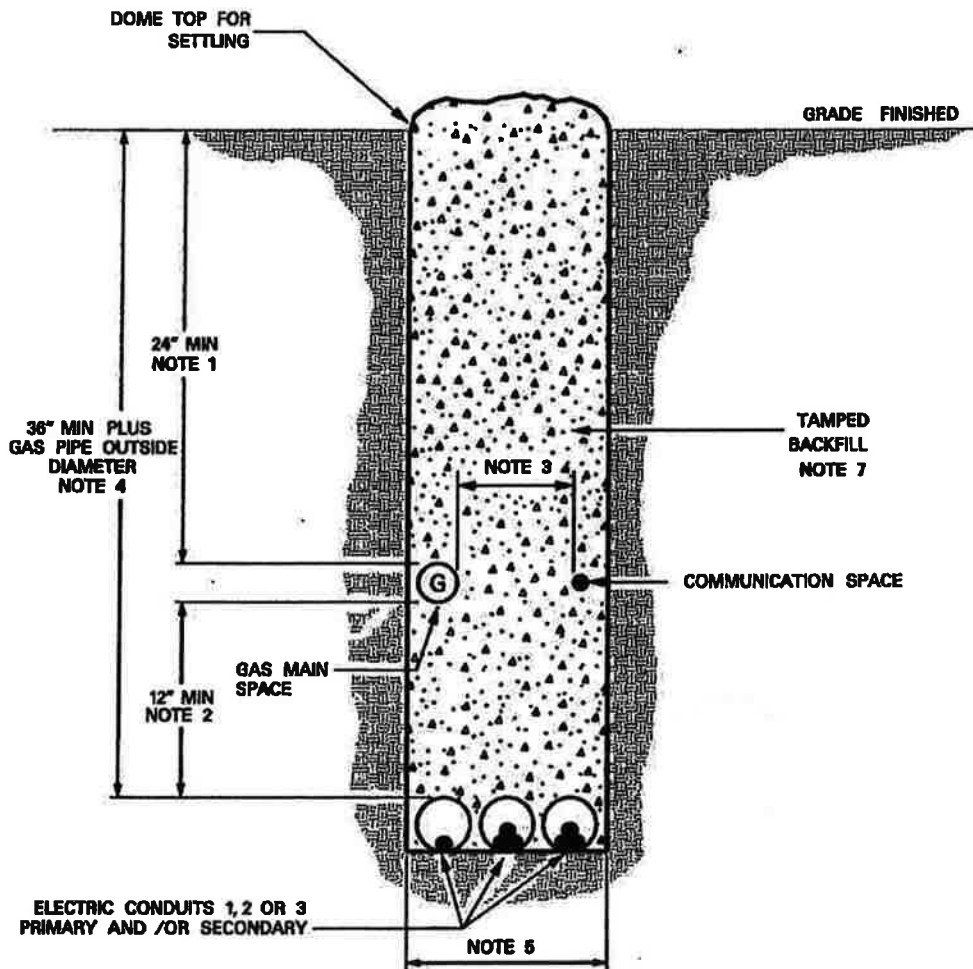

NOTES:

1. MINIMUM 24" DEPTH TO TOP OF BOTH GAS PIPE AND COMMUNICATION FACILITIES. TELCO SHALL NOT BE PLACED ABOVE THE GAS PIPE.
2. MINIMUM 12" VERTICAL SEPARATION BETWEEN SURFACE OF GAS, COMMUNICATION FACILITIES AND ELECTRICAL CONDUITS.
3. MINIMUM 12" HORIZONTAL SEPARATION BETWEEN SURFACE OF COMMUNICATION FACILITIES AND GAS PIPE.
4. MINIMUM 36" DEPTH PLUS PIPE OUTSIDE DIAMETER TO TOP OF ELECTRICAL CONDUITS.
5. TRENCH MUST BE WIDE ENOUGH TO ENSURE 12" SEPARATION AT ALL POINTS BETWEEN THE GAS MAIN AND COMMUNICATION FACILITIES.
6. THE GAS PIPE SHALL ONLY BE PLACED AGAINST UNDISTURBED SOIL THAT IS FREE OF STONES AND WHERE THERE ARE NO HARD PARTICLES LARGER THAN ONE-HALF INCH.
7. BACKFILL MATERIAL AND COMPACTION SHALL MEET OR EXCEED EACH UTILITY'S SPECIFICATIONS.



**JOINT USE TRENCH WITH
GAS, ELECTRIC
AND COMMUNICATION**

DDS-4 UG DETAIL SHEET 4 OF 57

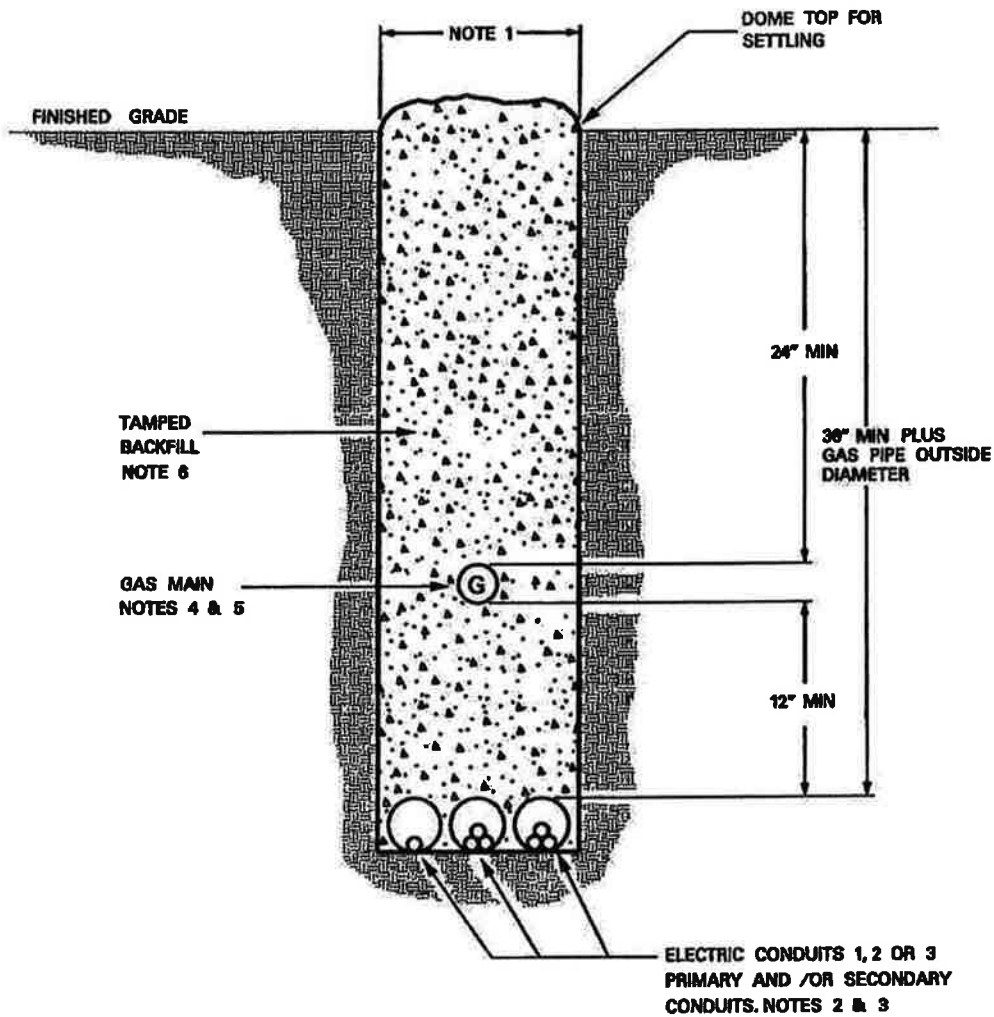

NOTES:

1. 12" MIN. WITH MORE THAN ONE ELECTRICAL SUPPLY CONDUIT.
4" MIN. WITH ONE ELECTRICAL SUPPLY CONDUIT (IN SOLID ROCK PIPE DIAMETER DETERMINES MIN. WIDTH).
2. CAPACITIES ARE REDUCED FOR MULTIPLE CIRCUITS IN A TRENCH.
3. SEE DETAIL SHEETS 7 AND 8 FOR NOTES AND INSTRUCTIONS.
4. THE GAS LINE IN A JOINT TRENCH SHALL BE POLYETHYLENE.
5. WHEN A GAS LINE CROSSES UNDER AN ENCLOSURE SUCH AS A PEDESTAL, PADMOUNT TRANSFORMER OR SPLICE/PULL BOX, IT WILL BE SLEEVED IN A SECTION OF POLYETHYLENE OR SCHEDULE 40 PVC. THE SLEEVE WILL EXTEND A MINIMUM OF THREE FEET BEYOND THE EDGE OF THE ENCLOSURE ON EACH SIDE. MAINTAIN A 12" SPARATION BETWEEN GAS LINE AND ELECTRICAL SUPPLY CONDUIT(S).
6. BACKFILL MATERIAL AND COMPACTION SHALL MEET OR EXCEED EACH UTILITY'S SPECIFICATIONS.



**TRENCH REQUIREMENTS
JOINT USE ELECTRIC AND GAS**

DDS-4 UG DETAIL SHEET 5 OF 57

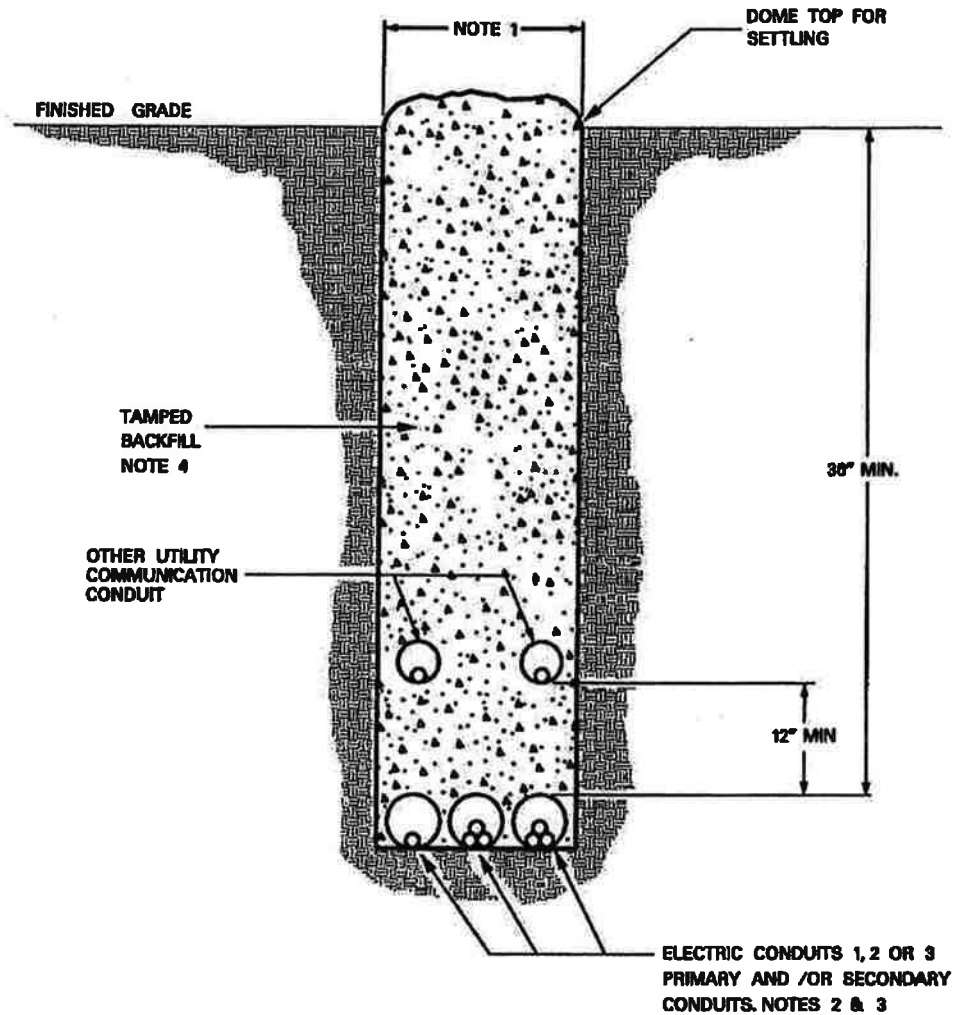

NOTES:

1. 12" MIN. WITH MORE THAN ONE ELECTRICAL SUPPLY CONDUIT.
4" MIN. WITH ONE ELECTRICAL SUPPLY CONDUIT (IN SOLID ROCK PIPE DIAMETER DETERMINES MIN. WIDTH).
2. AMPACITIES ARE REDUCED FOR MULTIPLE CIRCUITS IN A TRENCH.
3. SEE DETAIL SHEETS 7 AND 8 FOR NOTES AND INSTRUCTIONS.
4. BACKFILL MATERIAL AND COMPACTION SHALL MEET OR EXCEED EACH UTILITY'S SPECIFICATIONS.



**TRENCH REQUIREMENTS
JOINT USE
ELECTRIC AND COMMUNICATION**

DDS-4 UG DETAIL SHEET 6 OF 57

1. TRENCH ALIGNMENT SHALL BE AS STRAIGHT AS CONDITIONS PERMIT. ANY DEVIATIONS FROM PLANNED ALIGNMENT SHALL HAVE PRIOR APPROVAL BY THE PROJECT ENGINEER/INSPECTOR. ALL TRENCH CUTS SHALL BE IN ACCORDANCE WITH EXISTING SAFETY REGULATIONS IN EFFECT.
2. TRENCH BOTTOM SHOULD BE UNDISTURBED, TAMPED, OR RELATIVELY SMOOTH EARTH. WHERE EXCAVATION IS IN ROCK, THE CONDUIT SHOULD BE LAID ON A LAYER OF CLEAN BACKFILL.
3. ALL BACKFILL SHOULD BE FREE OF DEBRIS OR OTHER MATERIAL THAT MAY DAMAGE THE CONDUIT SYSTEM OR CAUSE SETTLING. THE MATERIAL SHOULD FILL THE VOIDS AROUND THE CONDUIT TO PREVENT HOT SPOTS & SETTLING.
4. BACKFILL SHOULD BE ADEQUATELY COMPACTED. BACKFILL NOT UNDER PAVEMENT SHOULD BE COMPACTED TO THE DENSITY OF THE SURROUNDING UNDISTURBED SOIL. BACKFILL UNDER PAVEMENT SHOULD BE COMPACTED TO NOT LESS THAN 95% OF THE DENSITY OF UNDISTURBED SOIL AS DETERMINED BY ASTM D-698.
5. SEE SHEET 8 FOR INSTRUCTIONS FOR JOINING PVC CONDUIT.
6. EACH CONDUIT RUN SHALL BE CHECKED BY PULLING A MANDREL THROUGH THE ENTIRE LENGTH AT THE COMPLETION OF THE CIVIL INSTALLATION.
7. A PULL TAPE SHALL BE LEFT IN EACH CONDUIT. CONDUIT SHALL BE PLUGGED AT BOTH ENDS.

APPROVED PULL TAPES

CONDUIT SIZE	MANUFACTURER	CATALOG NO.	TSN
1", 2", 3" & 4"	ARNCO	BL-WP25	321068
	NEPTCO, INC.	WP2500P	
6"	ARNCO	BL-WP60	397616
	NEPTCO, INC.	RP6000N	

8. CONTACT COMPANY REPRESENTATIVE FOR TRENCH DIMENSIONS FOR MORE THAN 2 CONDUITS IN SAME DITCH.



**INSTALLATION OF CONDUITS
NOTES AND INSTRUCTIONS**

DDS-4 UG DETAIL SHEET 7 OF 57

THE CHEMICALS USED IN SOLVENT WELDING OF CONDUIT ARE INTENDED TO PENETRATE THE SURFACE OF BOTH PIPE AND FITTING, WHICH AFTER CURING RESULT IN A COMPLETE FUSION AT THE JOINT. THE OVER-USE OR UNDER-USE OF CHEMICALS RESULTS IN LEAKY JOINTS OR WEAKENED PIPE.

A. CLEAN CONDUIT BY WIPING OFF ALL DUST, DIRT AND MOISTURE FROM SURFACES TO BE CEMENTED EITHER BY MECHANICAL OR CHEMICAL CLEANING.

1. MECHANICAL CLEANING - FINE ABRASIVE PAPER OR CLOTH (180 GRIT OR FINER) OR CLEAN OIL-FREE STEEL WOOL.
2. CHEMICAL CLEANING - CLEANER RECOMMENDED BY MANUFACTURER OR EQUIVALENT (METHYL ETHYL KETONE - MEK).

B. WITH A NON-SYNTHETIC BRISTLE BRUSH APPLY AN EVEN COATING OF CEMENT TO THE OUTSIDE OF THE PIPE AND INSIDE THE SOCKET. MAKE SURE THAT THE AMOUNT OF CEMENT APPLIED TO THE CONDUIT IS EQUAL TO THE DEPTH OF THE SOCKET. BEFORE ASSEMBLY, IF SOME EVAPORATION OF SOLVENT FROM THE SURFACES TO BE JOINED IS NOTED, REAPPLY CEMENT, THEN ASSEMBLE.

IF CEMENT BEING USED HAS AN APPRECIABLE CHANGE IN VISCOSITY OR SHOWS SIGNS OF JELLING, IT SHALL BE DISCARDED. IN NO CASE SHALL THINNER BE USED IN AN ATTEMPT TO RESTORE JELLED PVC CEMENT. THINNER MAY ONLY BE USED TO CHANGE THE VISCOSITY OF A MEDIUM BODIED CEMENT TO THAT OF A REGULAR BODIED CEMENT FOR APPLICATION ON PVC PIPE SMALLER THAN 2 1/2 INCH DIAMETER. A MEDIUM BODIED CEMENT SHALL BE USED ON 2 1/2 TO 6 INCH PVC PIPE.

IN COLD WEATHER, USE A PRIMER TO SOFTEN THE JOINING SURFACES BEFORE APPLYING CEMENT. ALLOW LONGER CURE TIME. (SEE ITEM E).

C. JOIN PIPE WITHIN 20 SECONDS OF APPLYING CEMENT. TURN THE PIPE 1/4 TURN TO ENSURE EVEN DISTRIBUTION OF CEMENT ON SURFACES TO BE BONDED. MAKE SURE THAT PIPE IS INSERTED TO THE FULL DEPTH OF THE SOCKET.

D. CLEAN OFF ANY BEAD OR EXCESS CEMENT THAT APPEARS AT THE OUTER SHOULDER OF THE FITTING. EXCESS CEMENT ALLOWED TO REMAIN IN CONTACT WITH THE MATERIAL IS APT TO CAUSE WEAKENING OF THE MATERIAL, AND SUBSEQUENT FAILURE.

E. NEWLY ASSEMBLED JOINTS SHOULD BE HANDLED CAREFULLY UNTIL THE CEMENT HAS CURED TO THE RECOMMENDED SET PERIOD. SET PERIODS ARE RELATED TO THE AMBIENT TEMPERATURE AS FOLLOWS:

- 30 MIN. MINIMUM AT 60° TO 100°F
- 1 HR. MINIMUM AT 40° TO 60°F
- 2 HR. MINIMUM AT 20° TO 40°F
- 4 HR. MINIMUM AT 0° TO 20°F



INSTRUCTIONS FOR JOINING PVC CONDUIT

DDS-4 UG DETAIL SHEET 8 OF 57

CONDUIT NOMINAL SIZE (IN.)	MINIMUM BEND RADIUS (IN.)	TYPE OF BEND MATERIAL FOR PULLS:
1	18	PVC
2	24	PVC
3	24	PVC
4	24	PVC
6	36	PVC

NOTES:

- SCH. 80 PVC CONDUIT SHALL BE USED FOR ALL ABOVE GROUND INSTALLATIONS (POLE AND METER RISERS). SCH. 40 MAY BE USED FOR ALL BELOW GROUND INSTALLATIONS.



**CONDUIT BEND RADIUS
AND MATERIAL**

DDS-4 UG DETAIL SHEET 9 OF 57

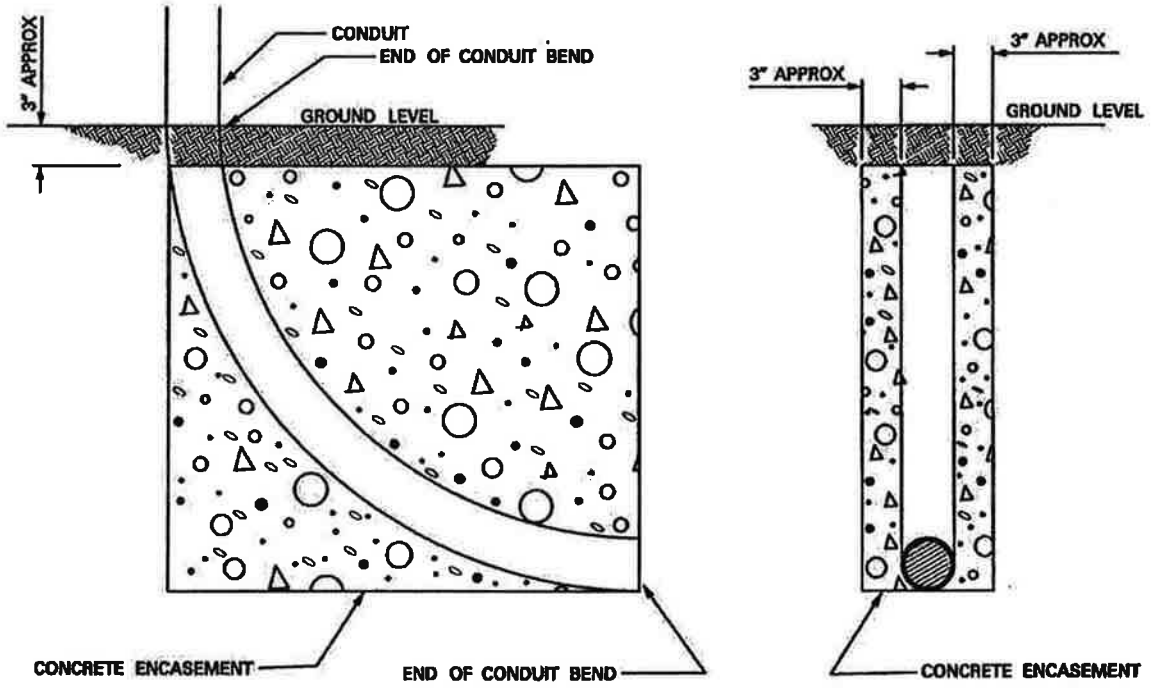

BEND	CONCRETE
1 INCH BEND	1.2 CUBIC FT.
2 INCH BEND	1.6 CUBIC FT.
3 INCH BEND	1.8 CUBIC FT.
4 INCH BEND	3.2 CUBIC FT.
6 INCH BEND	8.9 CUBIC FT.

TABLE 1

NOTES:

1. CONTACT COMPANY INSPECTOR TO DETERMINE REQUIREMENT FOR BEND ENCASEMENT.
2. DO NOT BOND CONCRETE TO POLE WHEN ENCASING A POLE RISER BEND.



CONCRETE ENCASED BENDS

DDS-4 UG DETAIL SHEET 10 OF 57

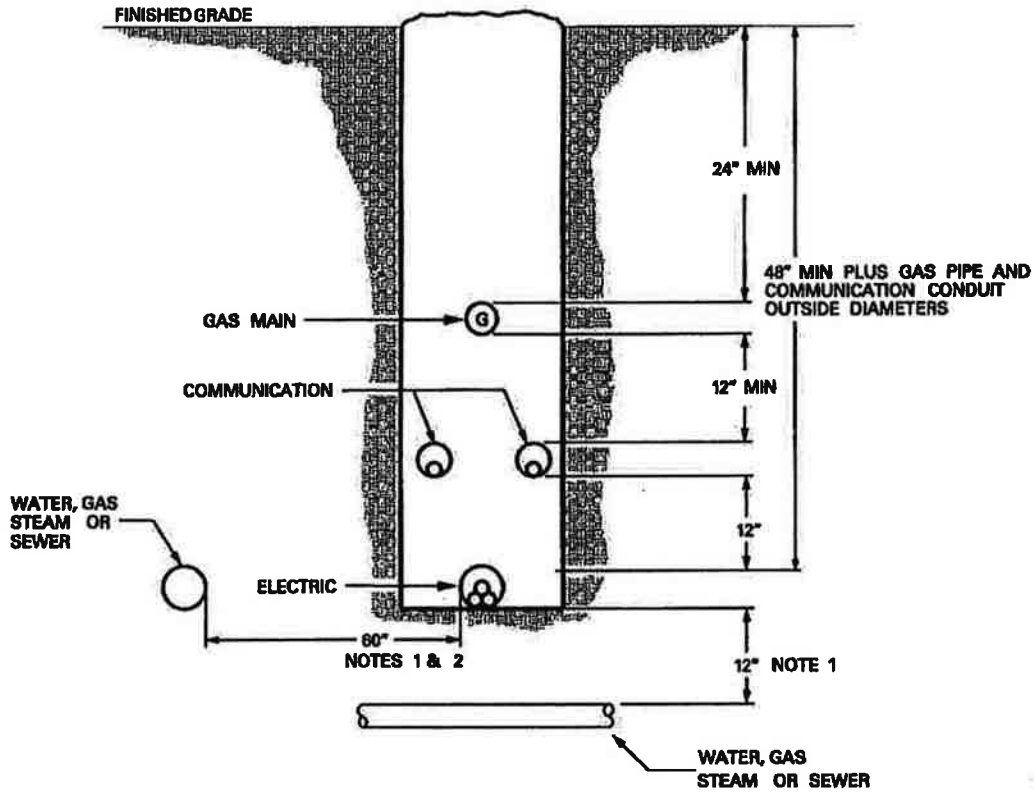

NOTES:

1. VERTICAL CROSSING CLEARANCE FROM OTHER UTILITIES SHALL BE 12 INCHES. A 60 INCH LATERAL SEPARATION OF PARALLELING FOREIGN UTILITIES (EXCLUDING GAS AND COMMUNICATIONS) SHALL BE REQUIRED. AN EXCEPTION WOULD BE TO ALLOW GAS, TELEPHONE AND /OR CATV IN THE SAME DITCH AS COMPANY CONDUIT SYSTEM PROVIDING THE NESC REQUIREMENTS FOR CONDUIT SEPARATION ARE MET OR EXCEEDED AND THE COMMUNICATIONS CIRCUITS ARE INSTALLED IN CONDUIT.
2. IT IS UNDERSTOOD THAT ONLY 12 INCH SEPARATION IS REQUIRED ON PUBLIC RIGHTS-OF-WAY. PERSONNEL INVOLVED IN EXCAVATION ON PUBLIC RIGHTS-OF-WAY ARE FULLY AWARE OF THE HAZARDS INVOLVED. HOWEVER, EXCAVATION ON PRIVATE PROPERTY CAN BE DONE BY INDIVIDUALS WHO ARE NOT LIKELY TO BE FULLY AWARE OF THE HAZARDS. THEREFORE, THE 60 INCH LATERAL SEPARATION IS REQUIRED TO HELP PREVENT INJURY TO PERSONNEL DOING EXCAVATION ON PRIVATE PROPERTY.



**CLEARANCE REQUIREMENTS
FROM FOREIGN UTILITIES
ON PRIVATE PROPERTY**

DDS-4 UG DETAIL SHEET 11 OF 57

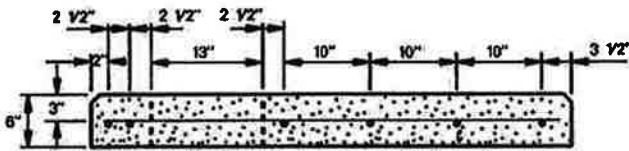
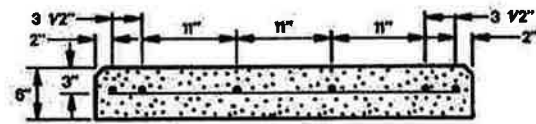
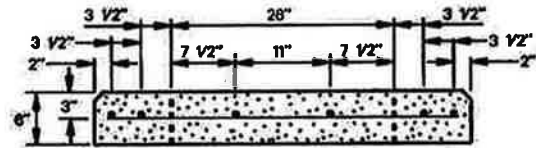
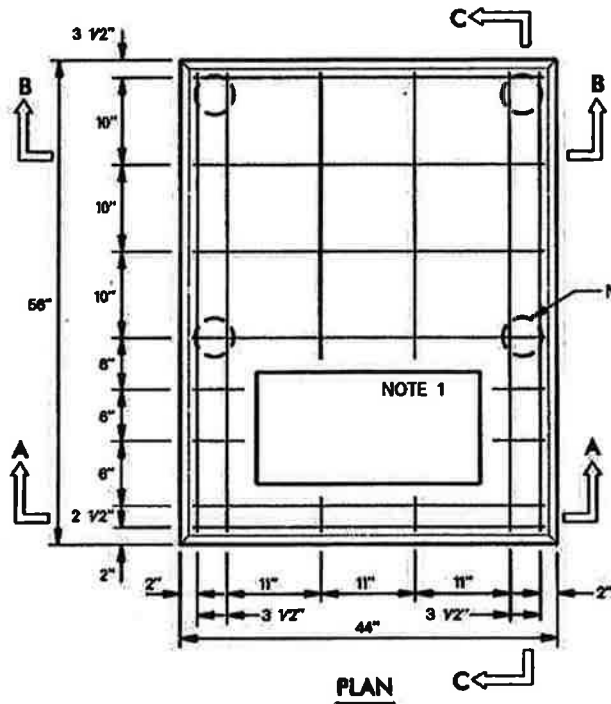

REINFORCING SCHEDULE		
NUMBER OF #3 BARS	LENGTH	WEIGHT (LBS)
4	53"	7.02
2	33"	2.13
2	4"	.19
6	41"	7.71
4	8"	.75

.28 CU YARDS CONCRETE
TOTAL WEIGHT OF PAD 1,100 LBS

NOTES:

1. SEE DETAIL SHEET 13 AND 14 FOR LOCATIONS OF CONDUITS AND GROUND ROD AND OTHER APPLICABLE NOTES.
2. PIERS ARE REQUIRED ON ALL PADS UNLESS WAIVED BY THE COMPANY INSPECTOR. REFERENCE DETAIL SHEET 17 FOR PIER INSTALLATION.
3. ALL STEEL TO BE A MINIMUM OF 1 1/2" FROM SURFACE OF CONCRETE.
4. ALL CHAMFERS TO BE 1 1/2" x 45 DEGREES. ROUNDING OF EDGES WITH ROUNDING TROWEL IS ACCEPTABLE IN LIEU OF CHAMFERING.
5. CONSULT COMPANY REPRESENTATIVE FOR APPROVED PREFABRICATED PADS.
6. SEE DETAIL SHEET 21 FOR GENERAL NOTES.
7. GROUT WINDOW AS PER DETAIL SHEET 15.



**POURED IN PLACE PAD
FOR SINGLE PHASE
TRANSFORMERS**

DDS-4 UG DETAIL SHEET 12 OF 57

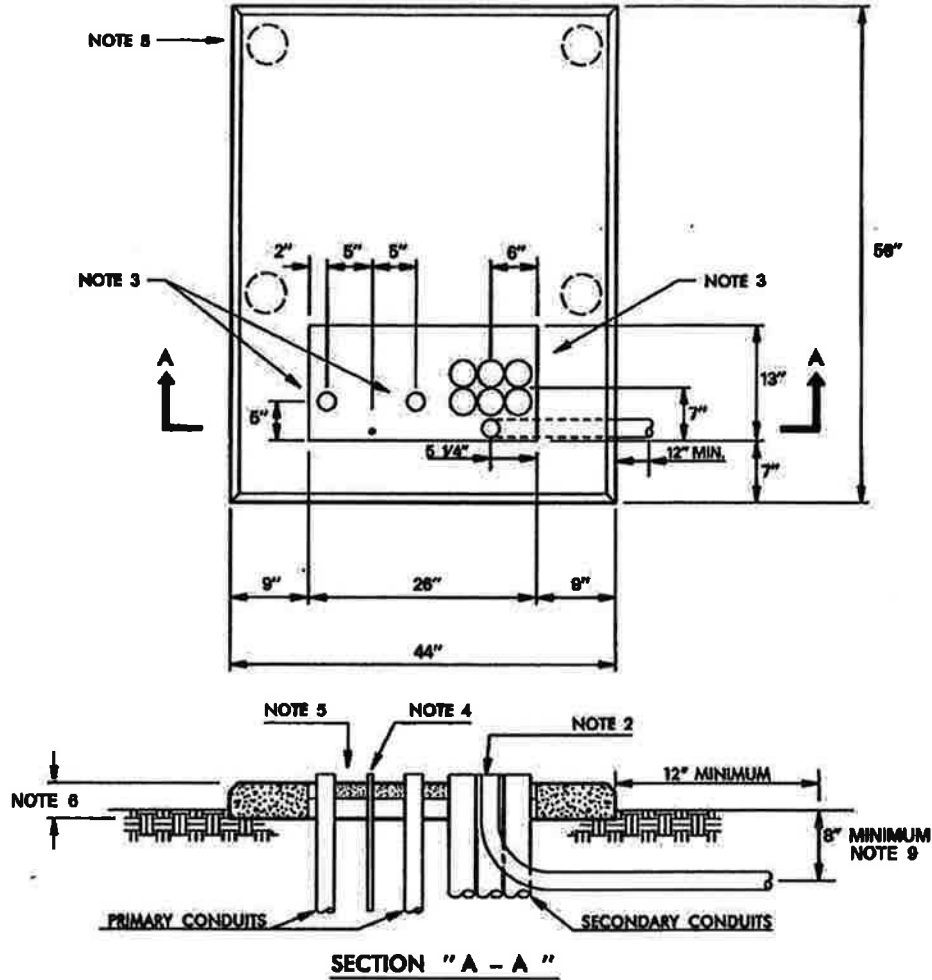

NOTES:

1. CONSULT COMPANY REPRESENTATIVE FOR (1) NUMBER, SIZE AND LOCATION OF CONDUITS IN PAD WINDOW AND (2) WHETHER DESIGN IS TYPE I OR TYPE II CONDUIT ARRANGEMENT.
2. NO MORE THAN 8- 2 INCH, 6- 3 INCH OR 4- 4 INCH CONDUITS INCLUDING SPARES SHALL BE PLACED IN THE SECONDARY SIDE OF PAD WINDOW.
3. REFERENCE DETAIL SHEET 9 FOR BEND RADIUS FOR ALL HORIZONTAL AND VERTICAL CONDUIT BENDS.
4. CONSULT COMPANY REPRESENTATIVE ON WHERE TO OBTAIN 5/8" X 8' COPPER CLAD GROUND ROD. GROUND ROD TO BE OBTAINED AND INSTALLED BY CONTRACTOR. INSTALLATION DEPTH SHALL BE 7'- 6".
5. GROUT WINDOW AS PER DETAIL SHEET 15.
6. THIS DIMENSION IS 6 INCHES FOR PRECAST CONCRETE PAD AND 4 INCHES FOR POLYMER CONCRETE PADS.
7. REFERENCE DETAIL SHEET 18 FOR FOREIGN UTILITY EQUIPMENT GROUND.
8. PIERS ARE REQUIRED ON ALL PADS UNLESS WAIVED BY COMPANY INSPECTOR. REFERENCE DETAIL SHEET 17 FOR PIER DETAIL.
9. THE 3" FLEX CONDUIT SHALL HAVE A MINIMUM OF 8" OF COVER AS IT EXITS ON THE RIGHT HAND SIDE OF THE TRANSFORMER PAD.



**TRANSFORMER PAD- PRECAST
SINGLE PHASE DEADFRONT
TYPE I**

DDS-4 UG DETAIL SHEET 13 OF 57

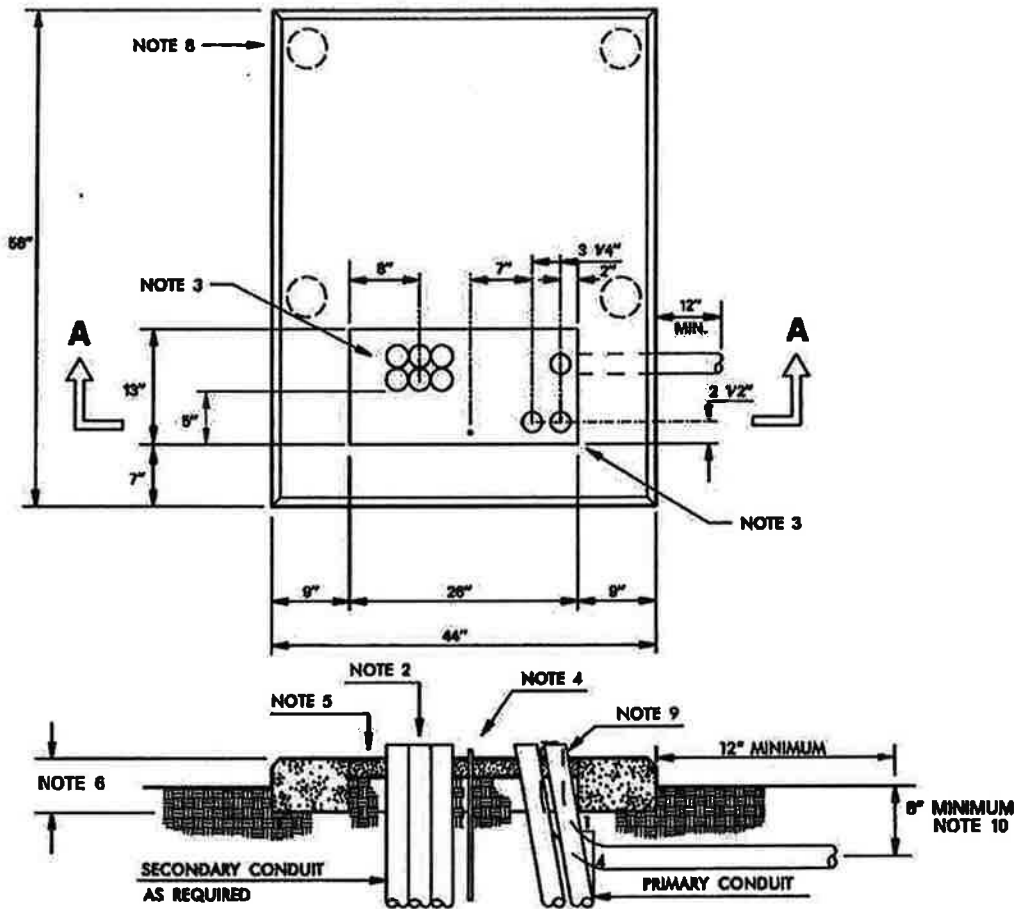

SECTION "A - A"

NOTES:

1. CONSULT COMPANY REPRESENTATIVE FOR (1) NUMBER, SIZE AND LOCATION OF CONDUITS IN PAD WINDOW AND (2) WHETHER TYPE I OR TYPE II CONDUIT ARRANGEMENT.
2. NO MORE THAN 8- 2 INCH, 6- 3 INCH OR 4- 4 INCH CONDUITS INCLUDING SPARES SHALL BE PLACED IN THE SECONDARY SIDE OF PAD WINDOW.
3. REFERENCE DETAIL SHEET 9 FOR BEND RADIUS FOR ALL HORIZONTAL AND VERTICAL CONDUIT BENDS.
4. CONSULT COMPANY REPRESENTATIVE ON WHERE TO OBTAIN 5/8" X 8' COPPER CLAD GROUND ROD. GROUND ROD TO BE OBTAINED AND INSTALLED BY CONTRACTOR. INSTALLATION DEPTH SHALL BE 7'- 8".
5. GROUT WINDOW AS PER DETAIL SHEET 15.
6. THIS DIMENSION IS 8 INCHES FOR PRECAST CONCRETE PAD AND 4 INCHES FOR POLYMER CONCRETE PADS.
7. REFERENCE DETAIL SHEET 18 FOR FOREIGN UTILITY EQUIPMENT GROUND.
8. PIERS ARE REQUIRED ON ALL PADS UNLESS WAIVED BY COMPANY INSPECTOR. REFERENCE DETAIL SHEET 17 FOR PIER DETAIL.
9. THE CONDUITS MUST BE INSTALLED TO ENSURE THAT THE TOTAL MAXIMUM BENDING RADIUS FOR THE PRIMARY CABLE DOES NOT EXCEED 9 INCHES (ANGLE PRIMARY CONDUIT WHENEVER POSSIBLE).
10. THE 3" FLEX CONDUIT SHALL HAVE A MINIMUM OF 8" OF COVER AS IT EXITS ON THE RIGHT HAND SIDE OF THE TRANSFORMER PAD.



**TRANSFORMER PAD- PRECAST
SINGLE PHASE DEADFRONT
TYPE II**

DDS-4 UG DETAIL SHEET 14 OF 57

SEE WINDOW DETAIL BELOW

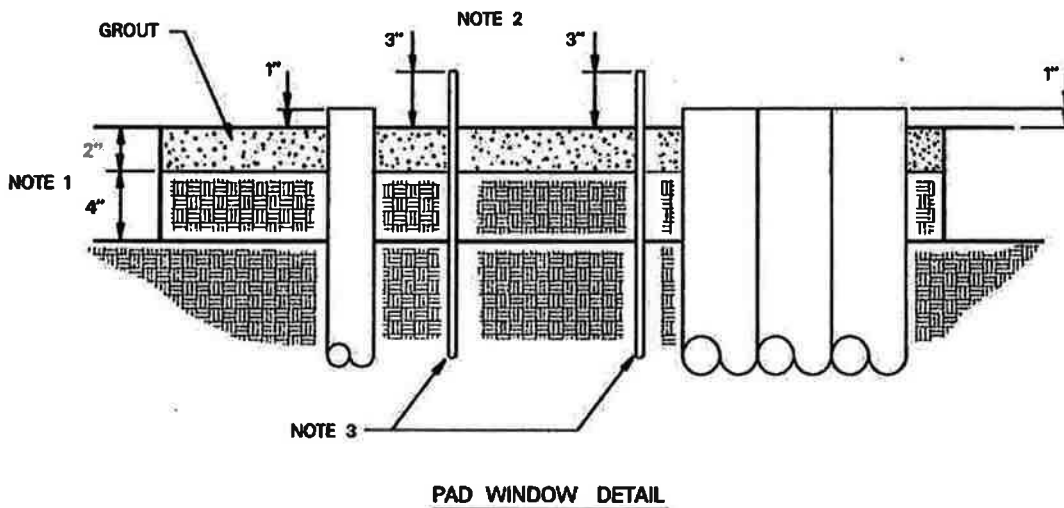
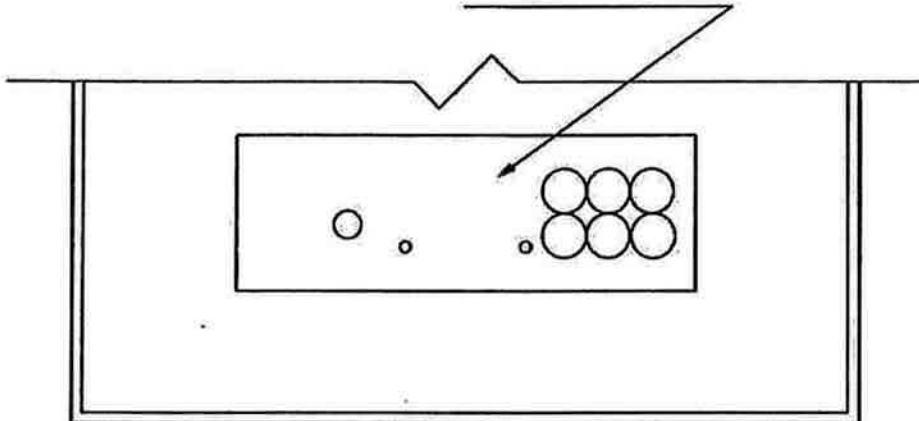

NOTES:

1. THE GROUT SHALL BE PORTLAND BASED AND SANDED. DO NOT USE CONCRETE.
2. FILL IN PAD WINDOW WITH 4 INCHES OF EARTH BACKFILL AND 2" OF GROUT.
3. GROUND RODS SHALL EXTEND A MAXIMUM OF 3 INCHES ABOVE GROUTING TO ASSURE ADEQUATE DRIVEN DEPTH AND ALLOW FOR ADEQUATE CONNECTING SPACE.
4. GROUND RODS SHALL EXTEND A MINIMUM OF 7'- 6" INTO EARTH.
5. GRAVEL FILL IS NOT ACCEPTABLE.



**GROUTING DETAIL
FOR TRANSFORMER
PAD WINDOWS**

DDS-4 UG DETAIL SHEET 15 OF 57

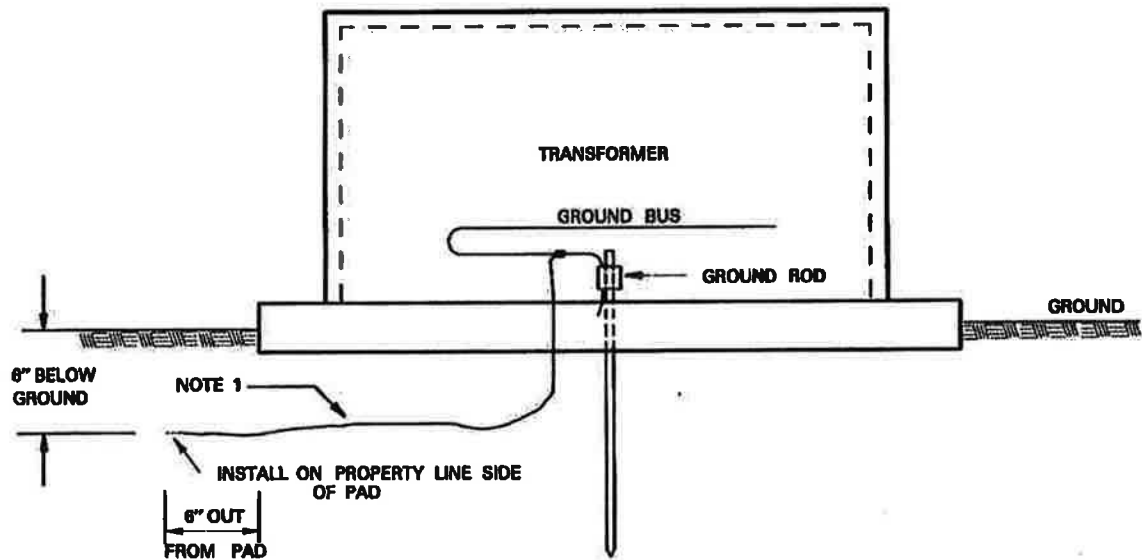
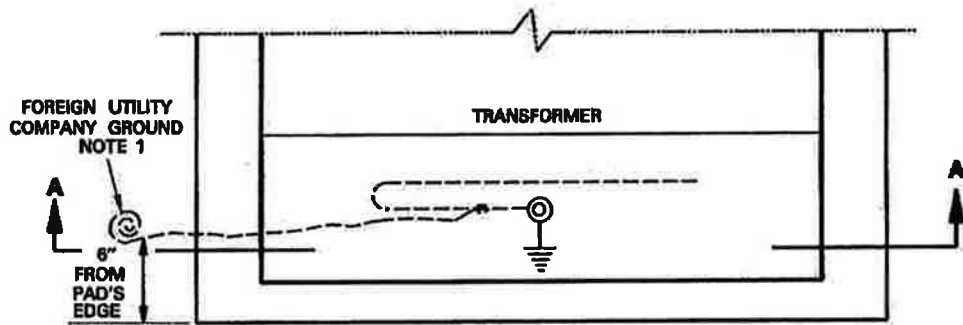

SECTION A-A

NOTES:

1. ON NEW INSTALLATIONS, INSTALL NO. 6 S.D. BARE COPPER AS SHOWN FOR FOREIGN UTILITY COMPANY BONDING.
2. THE NATIONAL ELECTRICAL SAFETY CODE RULE 384C RECOMMENDS BONDING OF ALL ABOVE GROUND METALLIC POWER AND COMMUNICATIONS APPARATUS (PEDESTALS, TERMINALS, APPARATUS CASES, TRANSFORMER CASES, ETC.) THAT ARE SEPARATED BY A DISTANCE OF 6 FEET OR LESS.



**METHOD OF PROVIDING
UTILITY COMPANY
EQUIPMENT GROUND**

DDS-4 UG DETAIL SHEET 16 OF 57

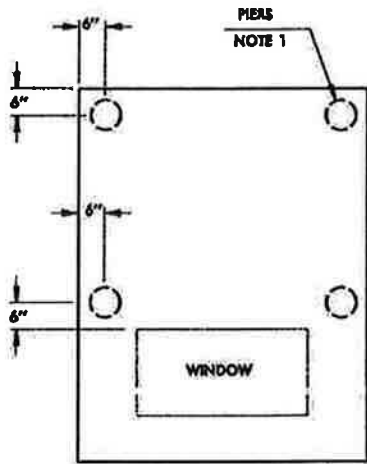

TRANSFORMER PAD

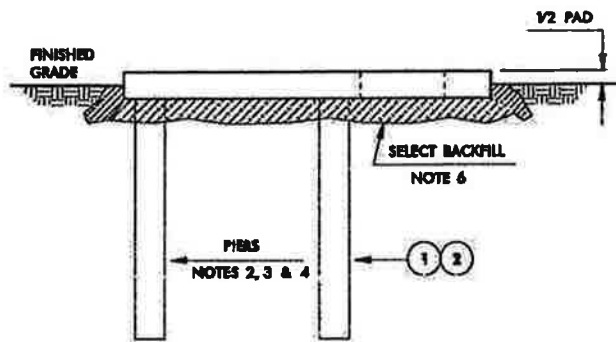

SIDE VIEW FOR LEVEL TERRAIN

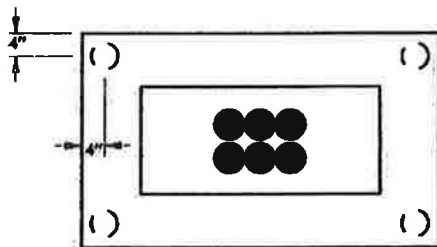

SERVICE ENCLOSURE

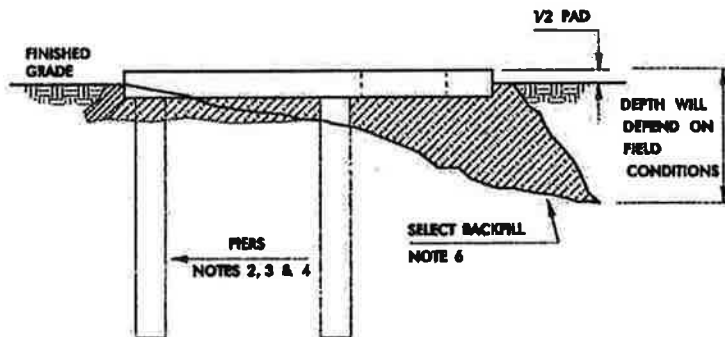

SIDE VIEW FOR SLOPING TERRAIN

NOTES:

1. PIERS SHALL BE INSTALLED UNDER PAD WHEN DIRT HAS BEEN DISTURBED UNDER THE LOAD BEARING AREA OF PAD. TAMP BACKFILL (95% COMPACTION) TO TOP OF PIER SUPPORTS (USE DITCH SPOIL WHEN POSSIBLE).
2. CUT SUPPORT PIERS FROM SECTION OF 4 IN. PVC CONDUIT.
3. PLACE PIERS AS SHOWN. FILL WITH CONCRETE.
4. TOP OF PIERS SHOULD BE LEVEL AND 3 IN. BELOW FINAL GROUND LEVEL TO A DEPTH OF:
 - (1) MINIMUM OF 36 IN. IN UNDISTURBED EARTH (SOIL).
 - (2) BOTTOM OF DITCH.
 - (3) BEGINNING OF SOLID ROCK.
5. AFTER PLACING PAD, FILL VOIDS UNDER AND AROUND PAD WITH SELECT DITCH SPOIL.
6. ALL BACKFILL UNDER AND AROUND PAD SHALL BE WELL TAMPED.



**SINGLE PHASE TRANSFORMER PAD
AND SERVICE ENCLOSURE
PIER INSTALLATION**

DDS-4 UG DETAIL SHEET 17 OF 57

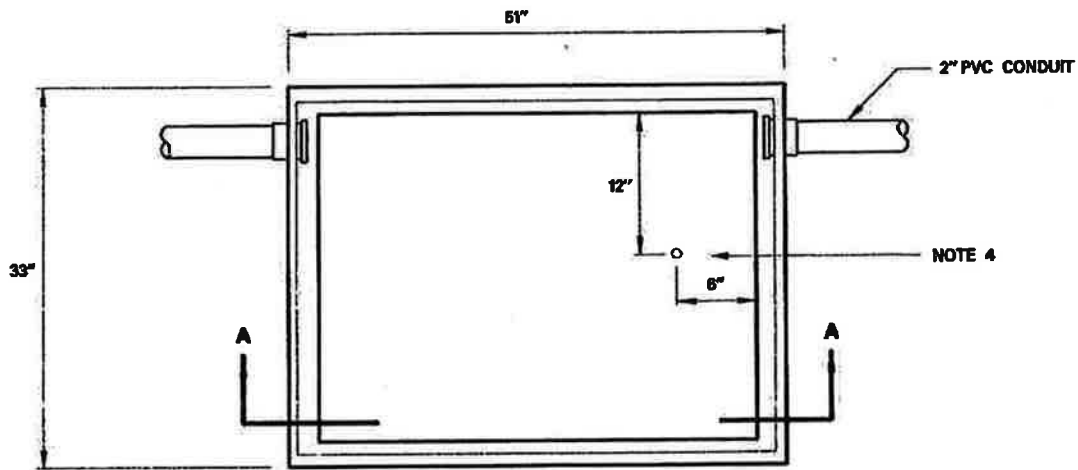

TOP VIEW

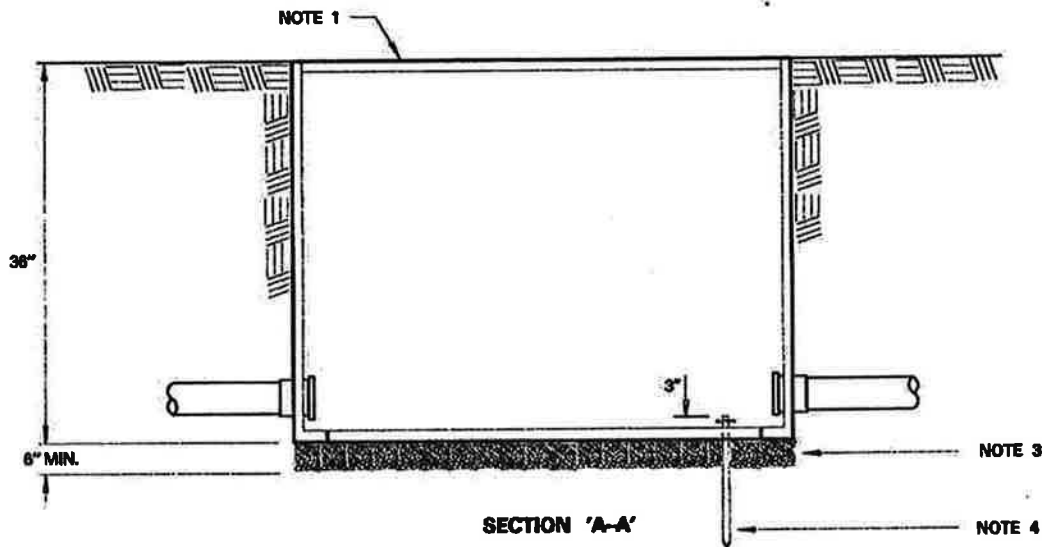

SECTION 'A-A'

NOTES:

1. 30" X 48" X 36" SPLICE/PULL BOX DESIGNED FOR PARKWAY INSTALLATION WITH H10 LOADING (LIGHT TRAFFIC). CONTACT COMPANY REPRESENTATIVE ON WHERE TO ACQUIRE SUBSURFACE SPLICE/PULL BOX.
2. THIS BOX IS INTENDED FOR USE AS AN INTERMEDIATE SPLICE BOX AS NEEDED DUE TO LONG PULLING DISTANCES AND RESTRICTED TO SINGLE #10 CABLE.
3. TAMP ALL DISTURBED SOIL UNDERNEATH PAD TO 95% COMPACTION AS PER ASTM D 698 AND INSTALL A 6 INCH WELL TAMPED LAYER OF MEDIUM GRAVEL FILL.
4. CONTACT COMPANY REPRESENTATIVE ON WHERE TO ACQUIRE 5/8" X 8" COPPER CLAD GROUND ROD. GROUND ROD TO BE OBTAINED AND INSTALLED BY CONTRACTOR. INSTALLATION DEPTH SHALL BE 7' - 8'.



**SINGLE PHASE PRIMARY
SUBSURFACE SPLICE / PULL BOX
INSTALLATION**

DDS-4 UG DETAIL SHEET 18 OF 57

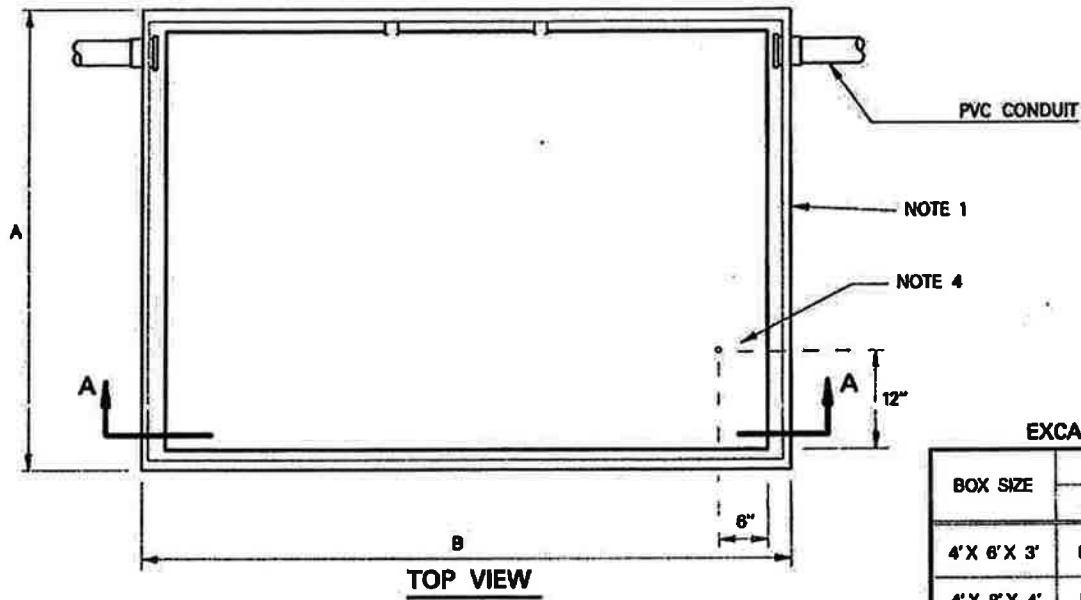

EXCAVATION

BOX SIZE	DIMENSIONS (IN)		
	A	B	C
4' X 6' X 3'	55	79	36
4' X 8' X 4'	56	104	48

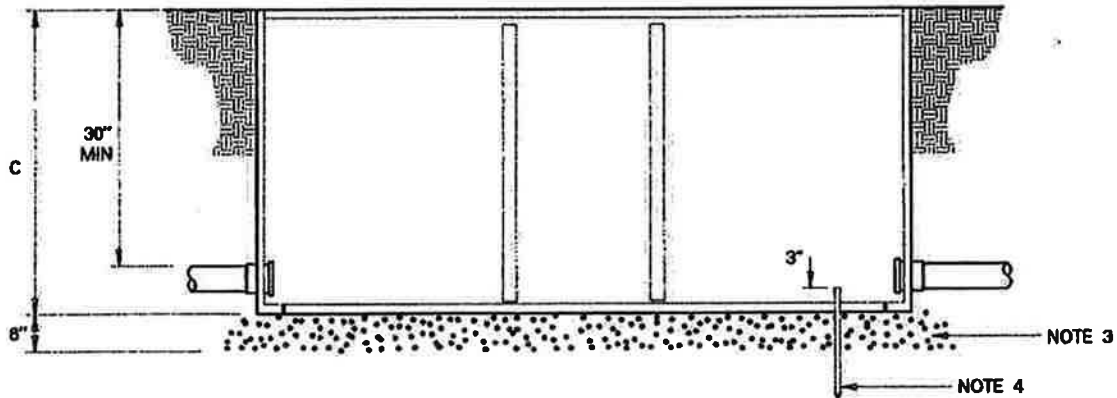

NOTES:

1. SPLICE/PULL BOX DESIGNED FOR PARKWAY INSTALLATION WITH H-10 LOADING (LIGHT VEHICULAR TRAFFIC). CONTACT COMPANY REPRESENTATIVE ON WHERE TO ACQUIRE SPLICE/PULL BOX.
2. THIS BOX IS INTENDED FOR USE AS AN INTERMEDIATE SPLICE BOX AS NEEDED DUE TO LONG PULLING DISTANCES AND RESTRICTED TO ONE 3 PHASE CIRCUIT.
3. TAMP ALL DISTURBED SOIL UNDERNEATH PAD TO 95% COMPACTION AS PER ASTM D 698 AND INSTALL A 8 INCH WELL TAMPED LAYER OF MEDIUM GRAVEL FILL.
4. CONTACT COMPANY REPRESENTATIVE ON WHERE TO ACQUIRE 5/8" X 8' COPPER CLAD GROUND ROD. GROUND ROD TO BE OBTAINED AND INSTALLED BY CONTRACTOR. INSTALLATION DEPTH SHALL BE 7'- 6".



**THREE PHASE PRIMARY
SUBSURFACE SPLICE / PULL BOX
INSTALLATION**

DDS-4 UG DETAIL SHEET 19 OF 57

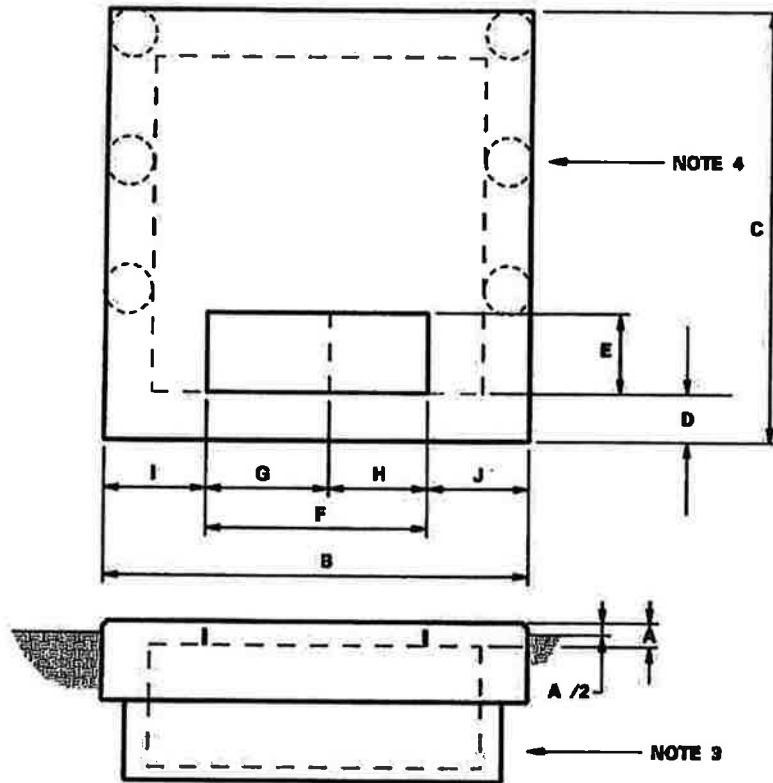

NOTES:

1. PADS SHALL BE CONSTRUCTED AS PER THE CONCRETE AND REBAR DETAIL SHEETS REFERENCED IN THE TABLE BELOW.
2. DF MEANS DEADFRONT AND LF MEANS LIVEFRONT.
3. CABLE SPREADER WELLS ARE REQUIRED ON LOOP FEED TRANSFORMER PADS. REFERENCE DETAIL SHEETS 28 THRU 37 FOR DIMENSIONS.
4. PIERS ARE REQUIRED ON ALL PADS UNLESS WAIVED BY THE COMPANY INSPECTOR. REFERENCE DETAIL SHEET 20 FOR PIER DETAILS.

KVA	A	B	C	D	E	F	G	H	I	J	REFERENCE DETAIL SHEET
75 - 150 RADIAL	6"	83"	83"	12"	16"	48"	28"	20"	21"	14"	24
225 - 500 RADIAL	6"	94"	94"	12"	16"	52"	28"	24"	25"	17"	25
750 - 1000 RADIAL	6"	96"	114"	12"	20"	52"	28"	24"	27"	17"	26
1500 - 2000 RADIAL	6"	114"	132"	12"	20"	52"	28"	24"	34"	28"	27
75 - 150 LF LOOP FEED	6"	83"	83"	12"	14"	56"	38"	18"	14"	13"	28 & 29
75 - 150 DF LOOP FEED	6"	83"	83"	12"	14"	62"	37"	25"	11"	10"	30 & 31
225 - 500 LF LOOP FEED	6"	96"	86"	12"	14"	60"	40"	20"	20"	16"	32 & 33
225 - 500 DF LOOP FEED	6"	96"	86"	12"	14"	62"	37"	25"	17"	17"	34 & 35
750 DF LOOP FEED	6"	96"	96"	12"	14"	62"	37"	25"	17"	17"	36 & 37



**TRANSFORMER PADS- CONCRETE
THREE PHASE PAD DIMENSIONS**

DDS-4 UG DETAIL SHEET 20 OF 57

1. CONTACT COMPANY REPRESENTATIVE FOR PAD SIZE AND NUMBER AND LOCATION OF PRIMARY AND SECONDARY CONDUITS.
2. REFERENCE DETAIL SHEET 9 FOR BEND RADIUS FOR ALL HORIZONTAL AND VERTICAL CONDUIT BENDS.
3. GROUND RODS TO BE OBTAINED AND INSTALLED BY CONTRACTOR. INSTALLATION DEPTH SHALL BE 7' - 8". REFERENCE DETAIL SHEETS FOR SIZE.
4. REFERENCE DETAIL SHEET 16 FOR LOCATION OF FOREIGN UTILITY EQUIPMENT GROUND.
5. REFER TO DETAIL SHEETS 51, 52, 53 & 54 FOR MINIMUM CLEARANCES FROM SURROUNDING OBJECTS.
6. PIERS ARE REQUIRED ON ALL SINGLE PHASE TRANSFORMER PADS UNLESS WAIVED BY THE COMPANY INSPECTOR. REFERENCE DETAIL SHEET 17 FOR PIER DETAIL FOR SINGLE PHASE PADS.
7. BEAMS SHALL BE INSTALLED ON ALL THREE PHASE TRANSFORMER PADS SET IN UNSTABLE SOILS AND IN AREAS WHERE DRAINAGE COULD CAUSE SOIL UNDER THE PAD TO WASH OUT. THE DEPTH OF BEAMS SHALL BE AS SHOWN OR TO ROCK. IF ROCK IS ENCOUNTERED WITHIN THREE INCHES OF SURFACE, BEAMS ARE NOT REQUIRED.
8. PIERS ARE REQUIRED ON ALL THREE PHASE TRANSFORMER PADS AND ON ALL SWITCHGEAR PADS UNLESS WAIVED BY THE COMPANY INSPECTOR. REFERENCE DETAIL SHEETS 22 AND 23 FOR PIERS FOR THREE PHASE TRANSFORMER AND SWITCHGEAR PADS.
9. REINFORCING STEEL SHALL CONFORM TO ASTM A 615 AND SHALL BE DEFORMED, INTERMEDIATE GRADE (GRADE 60). ALL REINFORCING STEEL SHALL BE CLEANED OF ALL COATINGS THAT ADVERSELY AFFECT BONDING CAPACITY. ALL REINFORCING STEEL SHALL BE ACCURATELY POSITIONED AND RIGIDLY HELD IN PLACE DURING POURING.
10. ALL REINFORCING STEEL SHALL HAVE A 3 INCH CLEARANCE FROM THE BOTTOM. THERE SHALL BE A 3 INCH CLEARANCE FROM SIDES TO STEEL RUNNING PARALLEL THEREOF. THERE SHALL BE A 2 INCH CLEARANCE FROM END OF STEEL TO SIDES AND WINDOW.
11. OUTER SURFACE EDGES OF PADS TO BE CHAMFERED 1 1/2" x 45 DEGREES. ROUNDING OF EDGES WITH A ROUNDING TROWEL IS ACCEPTABLE IN LIEU OF CHAMFERING.
12. TAMP ALL DISTURBED SOIL UNDERNEATH PAD TO 95% COMPACTION AS PER ASTM D 698.
13. CONCRETE SHALL CONFORM TO ASTM C 150 FOR TYPE I OR TYPE III HIGH EARLY. CONCRETE SHALL BE PROPORTIONED TO PRODUCE A COMPRESSIVE STRENGTH OF 3000 PSI AT 28 DAYS. CONCRETE SLUMP SHALL BE 3- 4 INCHES.
14. AGGREGATES SHALL CONFORM TO ASTM C 33 AND SHALL BE CLEAN AND FREE FROM DELETERIOUS AMOUNTS OF ACIDS, ALKALIS, ORGANIC MATTER OR OTHER FOREIGN SUBSTANCES. THE MAXIMUM AGGREGATE SIZE SHALL NOT EXCEED 3/4 INCH.
15. MIXING WATER SHALL BE CLEAN AND FREE FROM OILS, ACIDS, ALKALIS, SALTS, ORGANIC MATERIALS OR OTHER SUBSTANCES THAT MAY BE DELETERIOUS TO CONCRETE OR STEEL.
16. NO ADMIXTURES WILL BE PERMITTED WITHOUT THE APPROVAL FROM THE COMPANY.
17. CONCRETE MAY BE MIXED ON THE JOB OR READY MIX CONCRETE MAY BE USED.
18. FOR CONCRETE MIXED ON THE JOB, A MIXER WITH A MINIMUM TWO (2) SACK CAPACITY SHALL BE USED. CEMENT AND AGGREGATES SHALL BE PROPORTIONED ON CALIBRATED SCALES. WATER FOR MIXING SHALL BE ACCURATELY MEASURED. ALL CONCRETE SHALL BE PLACED WITHIN ONE HOUR AFTER MIXING.
19. IF READY MIXED CONCRETE IS USED, THE DRIVER OF EACH TRUCK SHALL FURNISH A TICKET SHOWING THE TIME THE TRUCK WAS LOADED AT THE BATCH PLANT. ANY TRUCK WHICH HAS NOT DISCHARGED ITS COMPLETE LOAD ONE HOUR AND THIRTY MINUTES AFTER LOADING SHALL BE REJECTED UNLESS A RETARDANT, APPROVED BY THE COMPANY, HAS BEEN ADDED TO THE CONCRETE AT THE TIME OF BATCHING. READY MIXED CONCRETE SHALL CONFORM TO ASTM C 94.



**GENERAL NOTES FOR
POURED IN PLACE
CONCRETE PAD**

DDS-4 UG DETAIL SHEET 21 OF 57

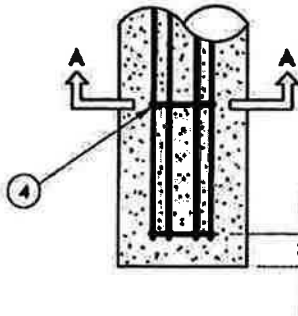
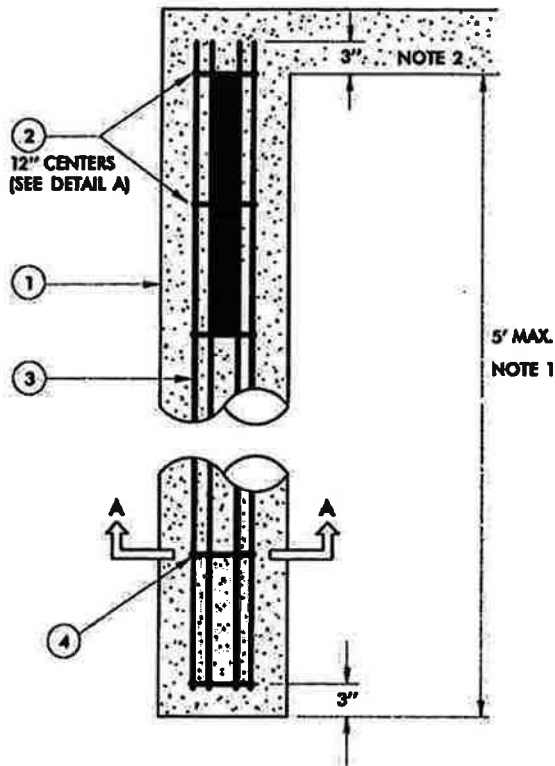

SECTION "A - A"

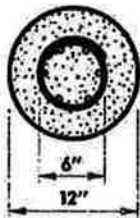

DETAIL A

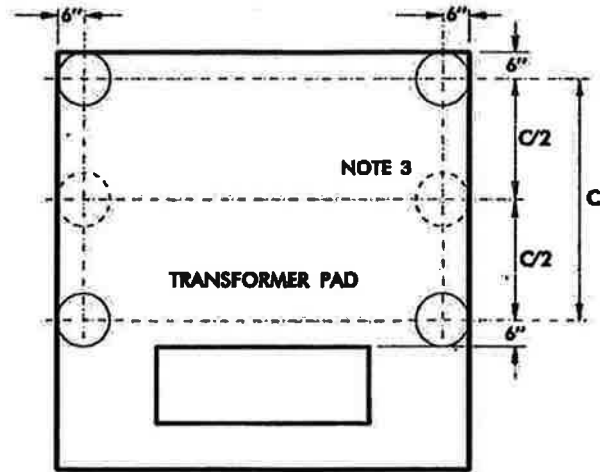

REINFORCING SCHEDULE			
NUMBER	SIZE	LENGTH	SHAPE
6	#5	5'	STRAIGHT
6	#3	2'-1"	HOOP (DETAIL A)

0.145 CU YARDS CONCRETE/PIER
TOTAL WEIGHT OF (1) PIER: 596 LBS.

NOTES:

- PIER DEPTH SHALL BE 5 FEET BELOW BOTTOM OF PAD UNLESS ROCK OR OTHER HARD SURFACES ARE ENCOUNTERED. IF ROCK OR OTHER HARD SURFACES ARE ENCOUNTERED PRIOR TO A 5 FOOT DEPTH, PIER DEPTH SHALL EXTEND 6-INCHES INTO THE HARD SURFACE.
- PIER REINFORCING TO EXTEND 3 INCHES INTO PAD.
- FOUR PIERS POSITIONED AS SHOWN ARE RECOMMENDED FOR ALL PAD SIZES EXCEPT THE 114" X 132" PAD. SIX PIERS POSITIONED AS SHOWN ARE RECOMMENDED FOR THIS PAD SIZE.
- SEE DETAIL SHEET 21 FOR ADDITIONAL NOTES.



**PIER DETAILS
FOR THREE PHASE
TRANSFORMER PADS**

DDS-4 UG DETAIL SHEET 22 OF 57

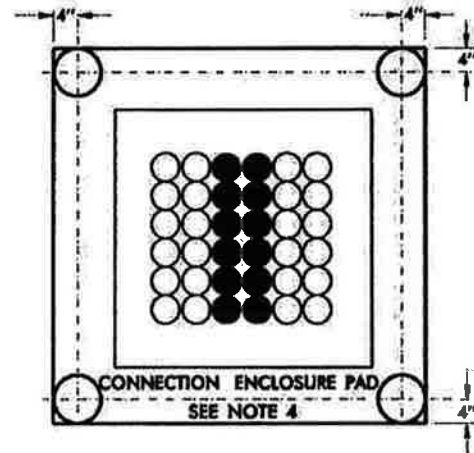
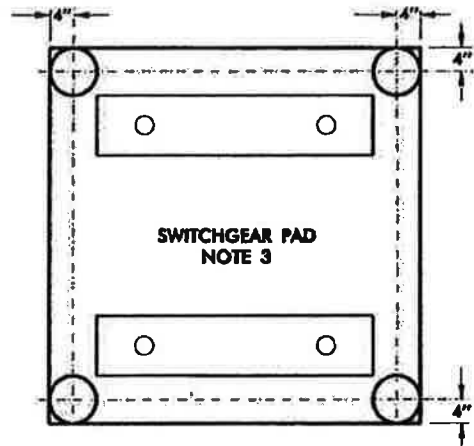
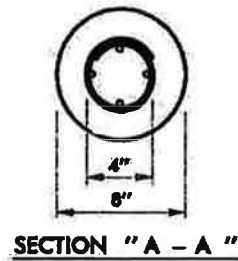
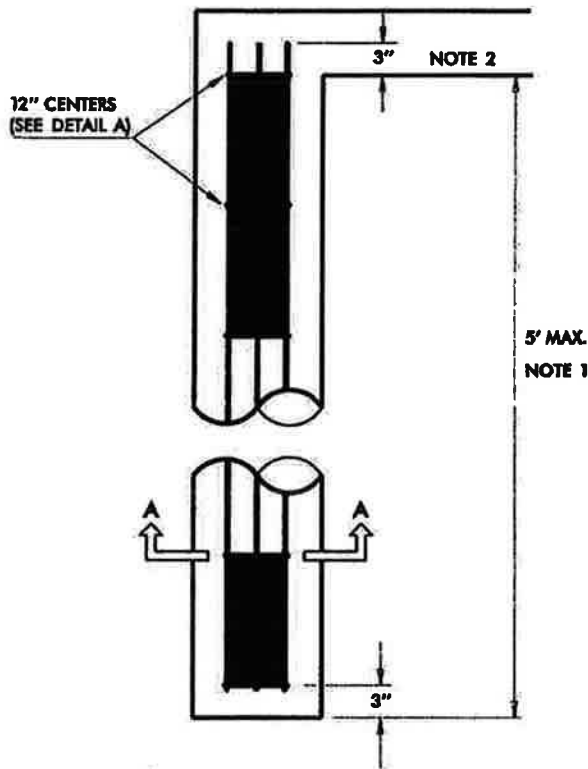

PIER REINFORCING SCHEDULE			
NUMBER	SIZE	LENGTH	SHAPE
4	#5	5'	STRAIGHT
6	#3	19"	HOOP [DETAIL A]

0.066 CU YARDS CONCRETE/PIER
 TOTAL WEIGHT OF (1) PIER: 278 LBS.

NOTES:

1. PIER DEPTH SHALL BE 5 FEET BELOW BOTTOM OF PAD UNLESS ROCK OR OTHER HARD SURFACES ARE ENCOUNTERED. IF ROCK OR OTHER HARD SURFACES ARE ENCOUNTERED PRIOR TO A 5 FOOT DEPTH, PIER DEPTH SHALL EXTEND 6 INCHES INTO THE HARD SURFACE.
2. PIER REINFORCING TO EXTEND 3 INCHES INTO PAD.
3. SEE DETAIL SHEETS 39, 40, 41, 42 AND 43 FOR CONCRETE SWITCHGEAR PAD DETAILS.
4. SEE DETAIL SHEETS 47 AND 48 FOR CONCRETE CONNECTION ENCLOSURE PAD DETAILS.
5. SEE DETAIL SHEET 21 NOTES.



**PIER DETAIL
 25 KV / 15 KV LIVEFRONT
 SWITCHGEAR PAD**

DDS-4 UG DETAIL SHEET 23 OF 57

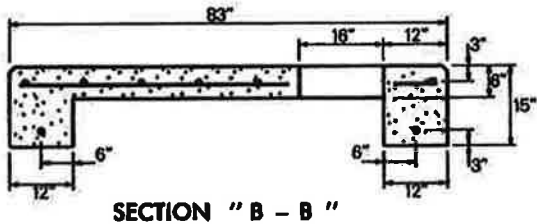
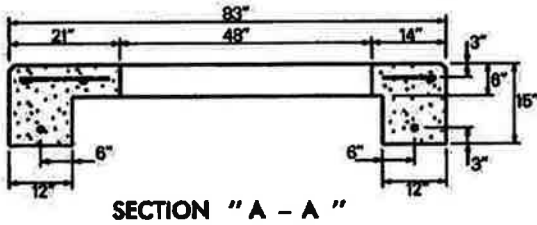
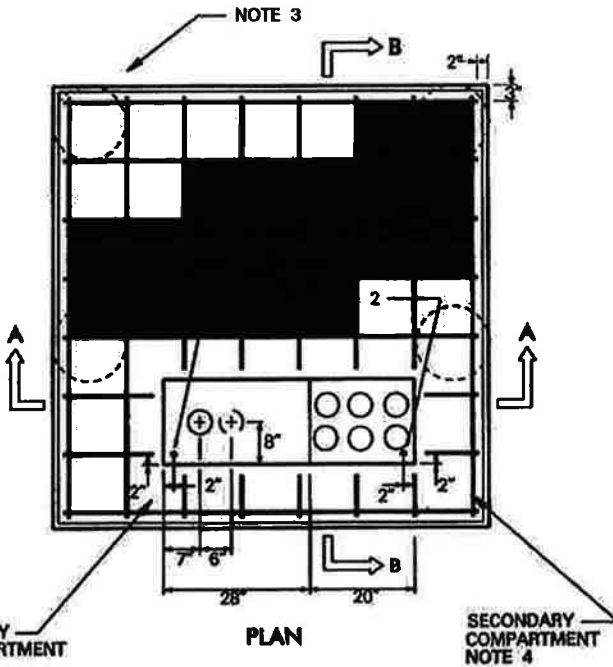

NOTES:

1. SEE DETAIL SHEET 21 FOR GENERAL NOTES.
2. CONTRACTOR TO OBTAIN AND INSTALL (2) 5/8" X 8' COPPER GROUND RODS AS SHOWN. INSTALLATION DEPTH SHALL BE 7' - 8'.
3. PIERS ARE REQUIRED ON ALL THREE PHASE TRANSFORMER PADS UNLESS WAIVED BY THE COMPANY INSPECTOR. REFERENCE DETAIL SHEET 22 FOR PIER DETAILS.
4. BEGIN SECONDARY CONDUITS AT RIGHT EDGE OF PAD WINDOW. ADD CONDUITS AS REQUIRED RIGHT TO LEFT. DO NOT CROSS DIVIDING LINE BETWEEN PRIMARY AND SECONDARY COMPARTMENTS.
5. GROUT WINDOW AS PER DETAIL SHEET 16.

REINFORCEMENT SPACING: 11" CENTERS

REINFORCING SCHEDULE PAD WITH BEAMS (NOTES 2 & 3)		
NUMBER OF #3 BARS	LENGTH	WEIGHT (LBS)
13	79"	32.2
5	51"	8.0
2	17"	1.1
2	10"	0.6
5	8"	1.2

1.4 CU YARDS CONCRETE
TOTAL WEIGHT OF PAD 5,850 LBS

REINFORCING SCHEDULE PAD WITHOUT BEAMS		
NUMBER OF #3 BARS	LENGTH	WEIGHT (LBS)
9	79"	22.3
5	51"	8.0
2	17"	1.1
2	10"	0.6
5	8"	1.2

0.8 CU YARDS CONCRETE
TOTAL WEIGHT OF PAD 3,190 LBS



**TRANSFORMER PAD
THREE PHASE
75 - 150 KVA RADIAL**

DDS-4 UG DETAIL SHEET 24 OF 57

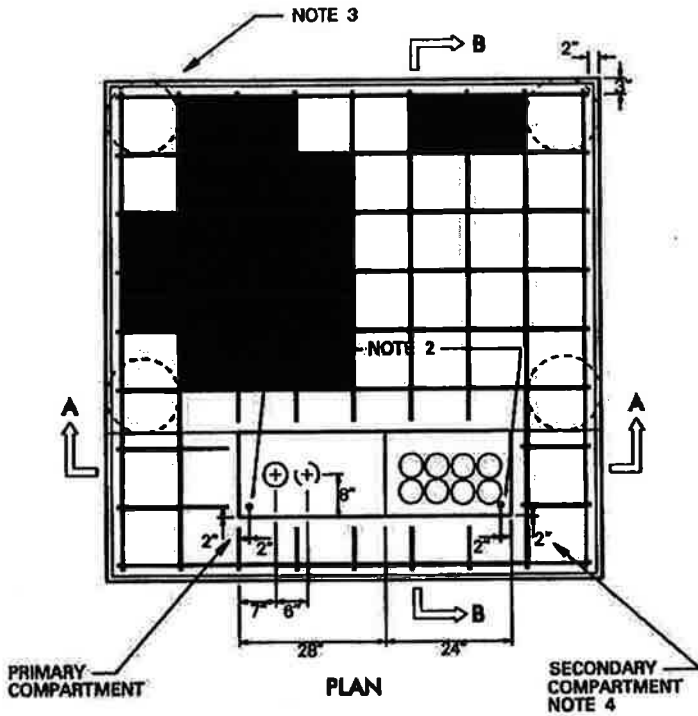

REINFORCEMENT SPACING: 11" CENTERS

REINFORCING SCHEDULE PAD WITH BEAMS (NOTES 2 & 3)		
NUMBER OF #3 BARS	LENGTH	WEIGHT (LBS)
15	90"	42.3
5	62"	9.7
2	21"	1.3
2	13"	0.8
5	8"	1.2

1.8 CU YARDS CONCRETE
TOTAL WEIGHT OF PAD 7,250 LBS

REINFORCING SCHEDULE PAD WITHOUT BEAMS		
NUMBER OF #3 BARS	LENGTH	WEIGHT (LBS)
11	90"	31.0
6	62"	9.7
2	21"	1.3
2	13"	0.8
6	8"	1.2

1.0 CU YARDS CONCRETE
TOTAL WEIGHT OF PAD 4,170 LBS

NOTES:

1. SEE DETAIL SHEET 21 FOR GENERAL NOTES.
2. CONTRACTOR TO OBTAIN AND INSTALL (2) 5/8" X 8' GROUND RODS AS SHOWN. INSTALLATION DEPTH SHALL BE 7'-6".
3. PIERS ARE REQUIRED ON ALL THREE PHASE TRANSFORMER PADS UNLESS WAIVED BY THE COMPANY INSPECTOR. REFERENCE DETAIL SHEET 22 FOR PIER DETAILS.
4. BEGIN SECONDARY CONDUITS AT RIGHT EDGE OF PAD WINDOW. ADD CONDUITS AS REQUIRED RIGHT TO LEFT, DO NOT CROSS DIVIDING LINE BETWEEN PRIMARY AND SECONDARY COMPARTMENTS.
5. GROUT WINDOW AS PER DETAIL SHEET 15.



**TRANSFORMER PAD
THREE PHASE
225 - 500 KVA RADIAL**

DDS-4 UG DETAIL SHEET 25 OF 57

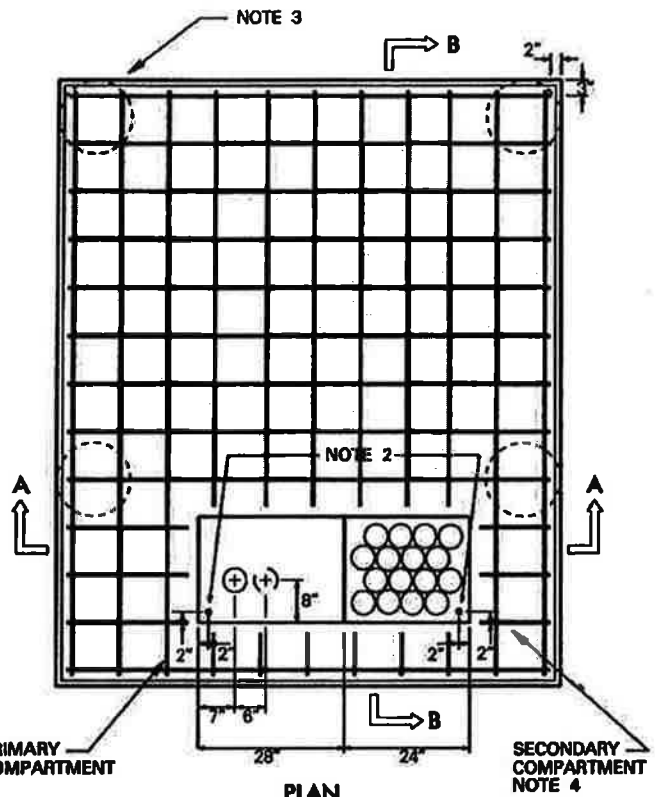

REINFORCEMENT SPACING: 8" CENTERS

REINFORCING SCHEDULE PAD WITH BEAMS (NOTES 2 & 3)		
NUMBER OF #3 BARS	LENGTH	WEIGHT (LBS)
12	92"	34.6
7	110"	24.1
6	78"	14.7
3	23"	2.2
3	13"	1.2
6	8"	1.5

2.1 CU YARDS CONCRETE
TOTAL WEIGHT OF PAD 8,645 LBS

REINFORCING SCHEDULE PAD WITHOUT BEAMS		
NUMBER OF #3 BARS	LENGTH	WEIGHT (LBS)
10	92"	28.8
5	110"	17.2
6	78"	14.7
3	23"	2.2
3	13"	1.2
6	8"	1.5

1.3 CU YARDS CONCRETE
TOTAL WEIGHT OF PAD 5,160 LBS

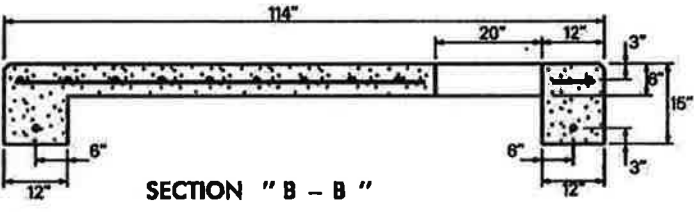
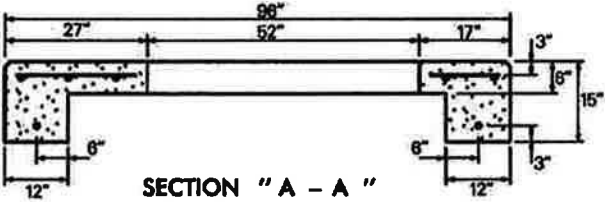

- NOTES:**
- SEE DETAIL SHEET 21 FOR GENERAL NOTES.
 - CONTRACTOR TO OBTAIN AND INSTALL (2) 5/8" X 8' GROUND RODS AS SHOWN. INSTALLATION DEPTH SHALL BE 7' - 8".
 - PIERS ARE REQUIRED ON ALL THREE PHASE TRANSFORMER PADS UNLESS WAIVED BY THE COMPANY INSPECTOR. REFERENCE DETAIL SHEET 22 FOR PIER DETAILS.
 - BEGIN SECONDARY CONDUITS AT RIGHT EDGE OF PAD WINDOW. ADD CONDUITS AS REQUIRED RIGHT TO LEFT. DO NOT CROSS DIVIDING LINE BETWEEN PRIMARY AND SECONDARY COMPARTMENTS.
 - GROUT WINDOW AS PER DETAIL SHEET 16.



**TRANSFORMER PAD
THREE PHASE
750 - 1000 KVA RADIAL
DDS-4 UG DETAIL SHEET 26 OF 57**

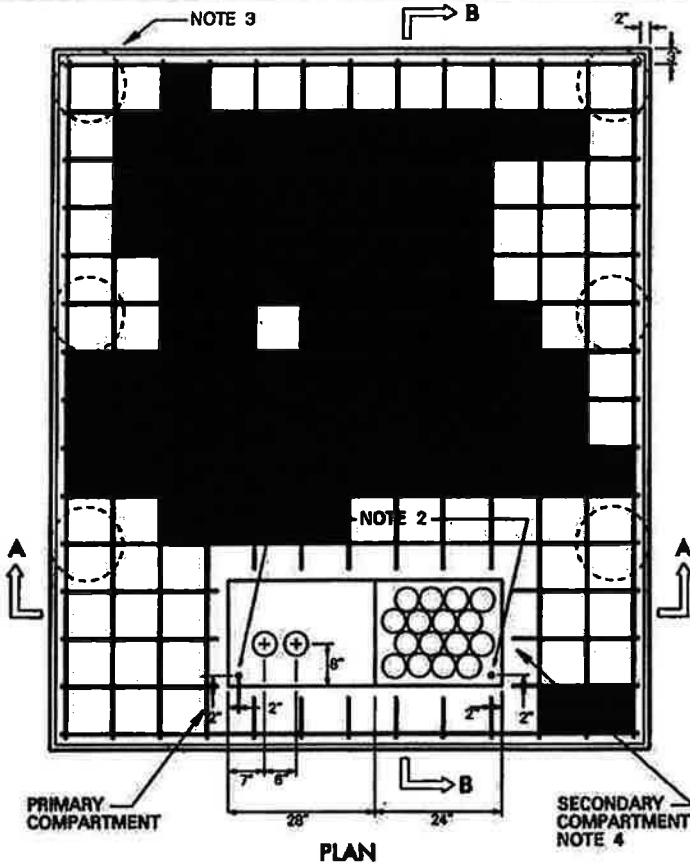

REINFORCEMENT SPACING: 9" CENTERS

REINFORCING SCHEDULE PAD WITH BEAMS (NOTES 2 & 3)		
NUMBER OF #3 BARS	LENGTH	WEIGHT (LBS)
9	128"	36.1
14	110"	48.2
6	98"	18.0
6	8"	1.5
3	30"	2.8
3	24"	2.2

2.8 CU YARDS CONCRETE
TOTAL WEIGHT OF PAD 11,400 LBS

REINFORCING SCHEDULE PAD WITHOUT BEAMS		
NUMBER OF #3 BARS	LENGTH	WEIGHT (LBS)
7	128"	28.1
12	110"	41.4
6	98"	18.0
6	8"	1.5
3	30"	2.8
3	24"	2.2

1.8 CU YARDS CONCRETE
TOTAL WEIGHT OF PAD 7,300 LBS

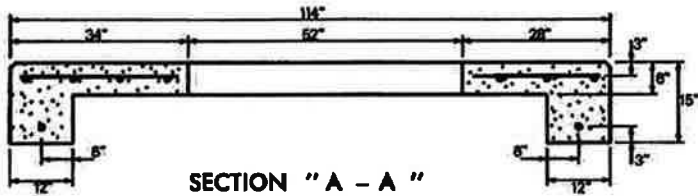

SECTION "A - A"

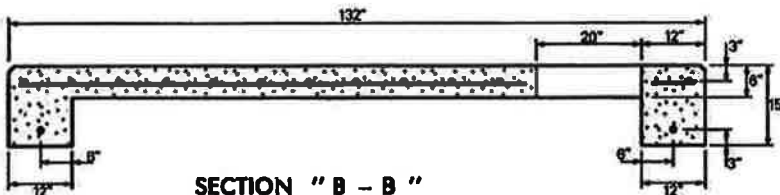

SECTION "B - B"

NOTES:

1. SEE DETAIL SHEET 21 FOR GENERAL NOTES.
2. CONTRACTOR TO OBTAIN AND INSTALL (2) 5/8" X 8' GROUND RODS AS SHOWN. INSTALLATION DEPTH SHALL BE 7'-6".
3. PIERS ARE REQUIRED ON ALL THREE PHASE TRANSFORMER PADS UNLESS WAIVED BY THE COMPANY INSPECTOR. REFERENCE DETAIL SHEET 22 FOR PIER DETAILS.
4. BEGIN SECONDARY CONDUITS AT RIGHT EDGE OF PAD WINDOW. ADD CONDUITS AS REQUIRED RIGHT TO LEFT. DO NOT CROSS DIVIDING LINE BETWEEN PRIMARY AND SECONDARY COMPARTMENTS.
5. GROUT WINDOW AS PER DETAIL SHEET 15.



**TRANSFORMER PAD
THREE PHASE
1500 - 2500 KVA RADIAL**

DDS-4 UG DETAIL SHEET 27 OF 57

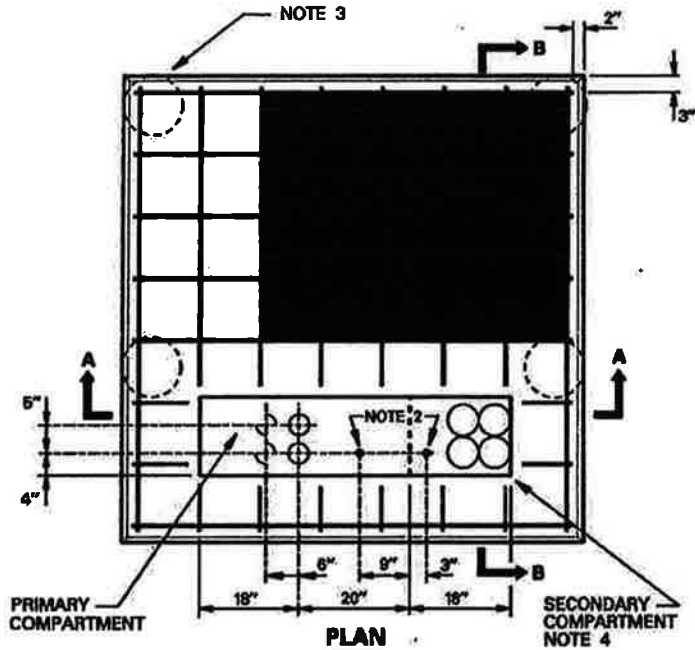

REINFORCEMENT SPACING: 11" CENTERS

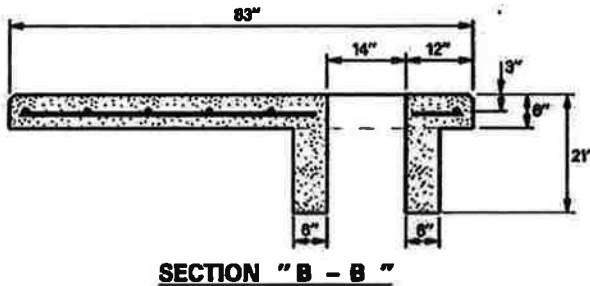
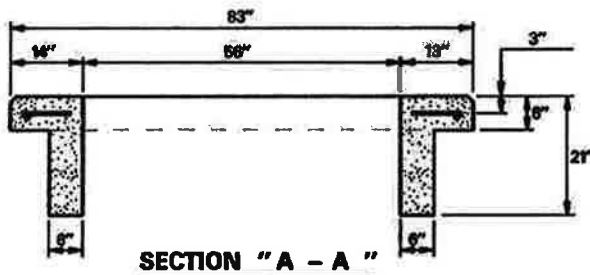

REINFORCING SCHEDULE PAD WITHOUT BEAMS		
NUMBER OF #3 BARS	LENGTH	WEIGHT (LBS)
8	79"	19.8
8	8"	1.50
2	9"	0.58
2	10"	0.83
6	53"	9.98

1.15 CU YARDS CONCRETE
TOTAL WEIGHT OF PAD 4,611 LBS

NOTES:

1. SEE DETAIL SHEET 21 FOR GENERAL NOTES.
2. CONTRACTOR TO OBTAIN AND INSTALL (2) 5/8" X 10' GROUND RODS AS SHOWN. INSTALLATION DEPTH SHALL BE 7' - 6".
3. PIERS ARE REQUIRED ON ALL THREE PHASE TRANSFORMER PADS UNLESS WAIVED BY THE COMPANY INSPECTOR. REFERENCE DETAIL SHEET 22 FOR PIER DETAILS.
4. BEGIN SECONDARY CONDUITS AT RIGHT EDGE OF PAD WINDOW. ADD CONDUITS AS REQUIRED RIGHT TO LEFT. DO NOT CROSS DIVIDING LINE BETWEEN PRIMARY AND SECONDARY COMPARTMENTS.
5. GROUT WINDOW AS PER DETAIL SHEET 15.



**TRANSFORMER PAD
THREE PHASE 75 - 150 KVA
LIVE FRONT LOOP FEED**

DDS-4 UG DETAIL SHEET 28 OF 57

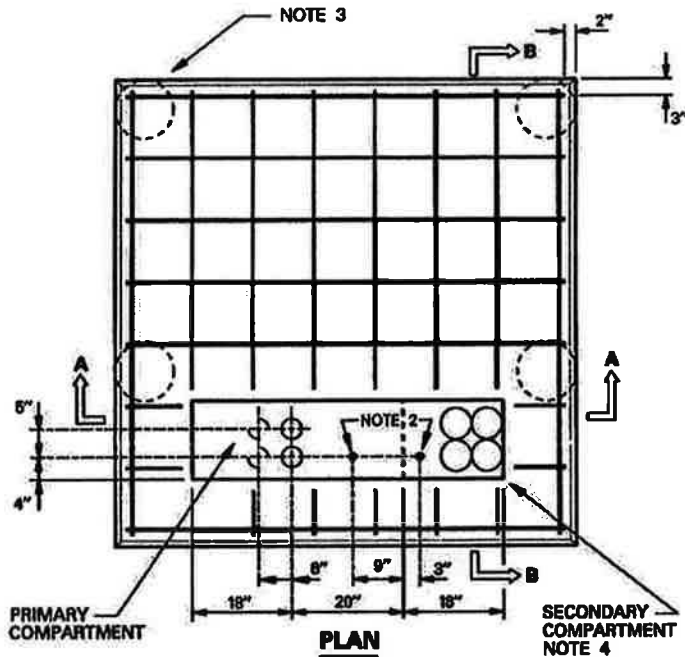

REINFORCEMENT SPACING: 11" CENTERS

REINFORCING SCHEDULE PAD WITH BEAMS (NOTES 4 & 5)		
NUMBER OF #3 BARS	LENGTH	WEIGHT (LBS)
12	79"	29.7
6	8"	1.50
2	9"	0.58
2	10"	0.83
6	53"	9.88

1.70 CU YARDS CONCRETE
TOTAL WEIGHT OF PAD 6,610 LBS

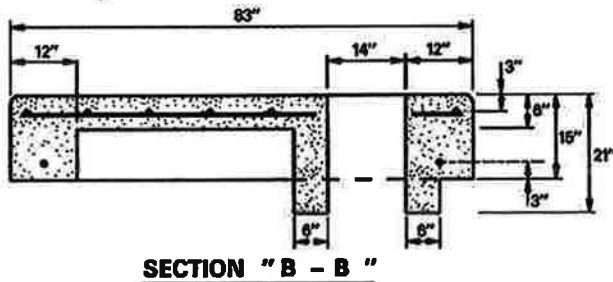
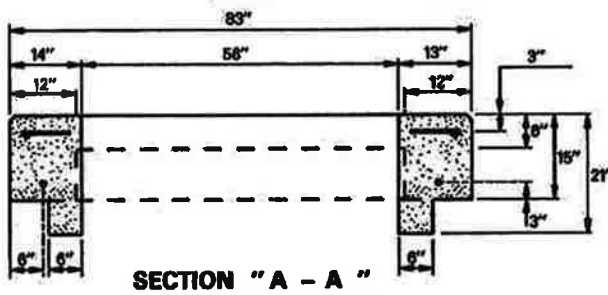

NOTES:

1. SEE DETAIL SHEET 21 FOR GENERAL NOTES.
2. CONTRACTOR TO OBTAIN AND INSTALL (2) 5/8" X 10' GROUND RODS AS SHOWN. INSTALLATION DEPTH SHALL BE 7' - 6".
3. PIERS ARE REQUIRED ON ALL THREE PHASE TRANSFORMER PADS UNLESS WAIVED BY THE COMPANY INSPECTOR. REFERENCE DETAIL SHEET 22 FOR PIER DETAILS.
4. BEGIN SECONDARY CONDUITS AT RIGHT EDGE OF PAD WINDOW, ADD CONDUITS AS REQUIRED RIGHT TO LEFT. DO NOT CROSS DIVIDING LINE BETWEEN PRIMARY AND SECONDARY COMPARTMENTS.
5. GROUT WINDOW AS PER DETAIL SHEET 15.



**TRANSFORMER PAD WITH BEAMS
THREE PHASE 75 - 150 KVA
LIVE FRONT LOOP FEED**

DDS-4 UG DETAIL SHEET 29 OF 57

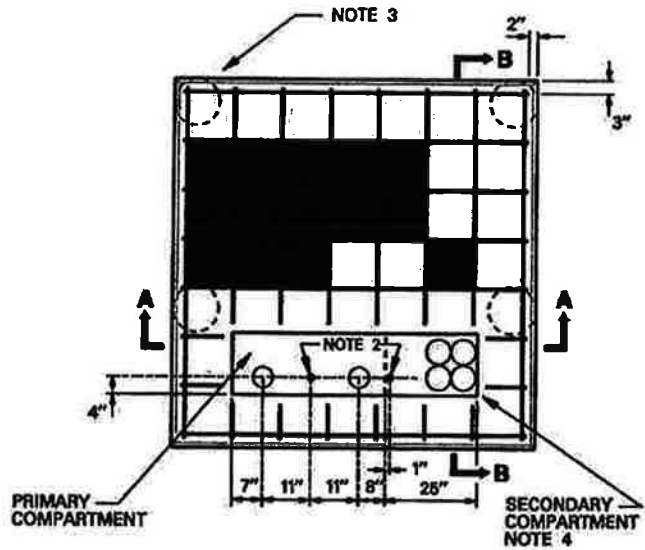

PLAN

REINFORCEMENT SPACING: 11" CENTERS

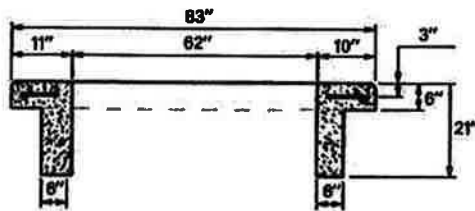

SECTION "A - A"

REINFORCING SCHEDULE PAD WITHOUT BEAMS		
NUMBER OF #3 BARS	LENGTH	WEIGHT (LBS)
8	79"	19.8
6	8"	1.50
2	6"	0.38
2	7"	0.44
6	63"	9.96

**1.17 CU YARDS CONCRETE
TOTAL WEIGHT OF PAD 4,500 LBS**

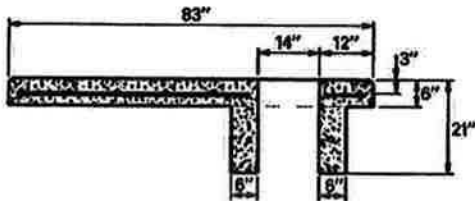

SECTION "B - B"

NOTES:

1. SEE DETAIL SHEET 21 FOR GENERAL NOTES.
2. CONTRACTOR TO OBTAIN AND INSTALL (2) 5/8" X 10' GROUND RODS AS SHOWN. INSTALLATION DEPTH SHALL BE 7' - 6".
3. PIERS ARE REQUIRED ON ALL THREE PHASE TRANSFORMER PADS UNLESS WAIVED BY THE COMPANY INSPECTOR. REFERENCE DETAIL SHEET 22 FOR PIER DETAILS.
4. BEGIN SECONDARY CONDUITS AT RIGHT EDGE OF PAD WINDOW. ADD CONDUITS AS REQUIRED RIGHT TO LEFT. DO NOT CROSS DIVIDING LINE BETWEEN PRIMARY AND SECONDARY COMPARTMENTS.
5. GROUT WINDOW AS PER DETAIL SHEET 15.



**TRANSFORMER PAD
THREE PHASE 75 - 150 KVA
DEADFRONT LOOP FEED**

DDS-4 UG DETAIL SHEET 30 OF 57

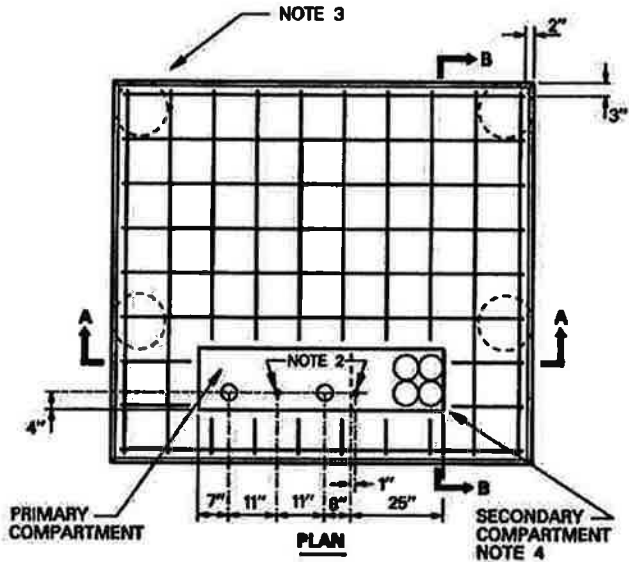

REINFORCEMENT SPACING: 11" CENTERS

REINFORCING SCHEDULE PAD WITH BEAMS (NOTES 4 & 5)		
NUMBER OF #3 BARS	LENGTH	WEIGHT (LBS)
12	79'	29.7
6	8"	1.50
2	8"	0.38
2	7"	0.44
6	53"	9.96

1.70 CU YARDS CONCRETE
TOTAL WEIGHT OF PAD 6,510 LBS

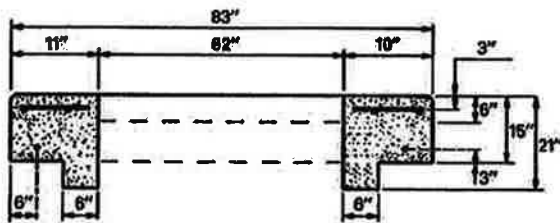

SECTION "A - A"

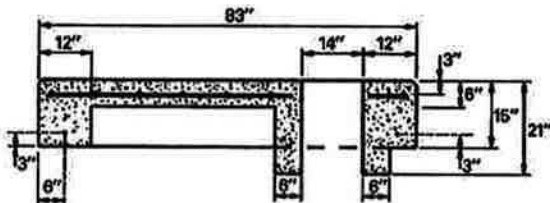

SECTION "B - B"

NOTES:

1. SEE DETAIL SHEET 21 FOR GENERAL NOTES.
2. CONTRACTOR TO OBTAIN AND INSTALL (2) 5/8" X 10' GROUND RODS AS SHOWN. INSTALLATION DEPTH SHALL BE 7'-6".
3. PIERS ARE REQUIRED ON ALL THREE PHASE TRANSFORMER PADS UNLESS WAIVED BY THE COMPANY INSPECTOR. REFERENCE DETAIL SHEET 22 FOR PIER DETAILS.
4. BEGIN SECONDARY CONDUITS AT RIGHT EDGE OF PAD WINDOW. ADD CONDUITS AS REQUIRED RIGHT TO LEFT. DO NOT CROSS DIVIDING LINE BETWEEN PRIMARY AND SECONDARY COMPARTMENTS.
5. GROUT WINDOW AS PER DETAIL SHEET 15.



**TRANSFORMER PAD WITH BEAMS
THREE PHASE 75 - 150 KVA
DEADFRONT LOOP FEED**

DDS-4 UG DETAIL SHEET 31 OF 57

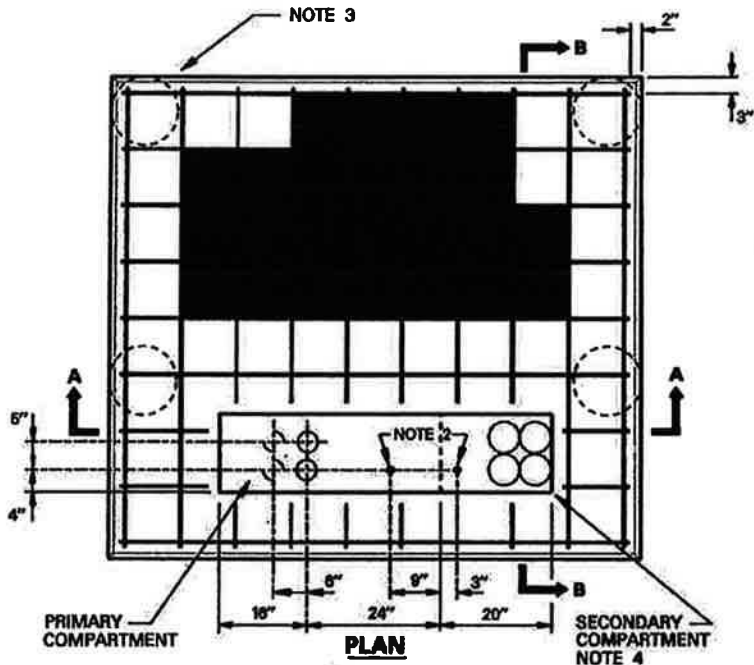

REINFORCEMENT SPACING: 10" CENTERS

REINFORCING SCHEDULE PAD WITHOUT BEAMS		
NUMBER OF #3 BARS	LENGTH	WEIGHT (LBS)
4	82"	10.3
6	66"	10.6
8	8"	1.50
2	16"	1.00
2	12"	0.75
7	92"	20.2

1.34 CU YARDS CONCRETE
TOTAL WEIGHT OF PAD 6,262 LBS

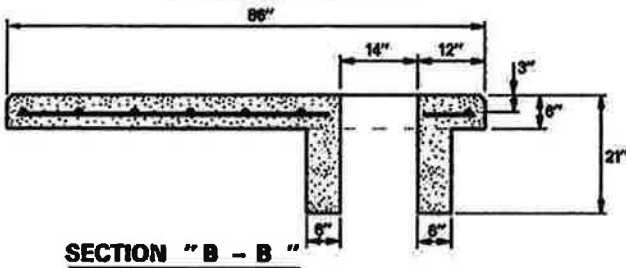
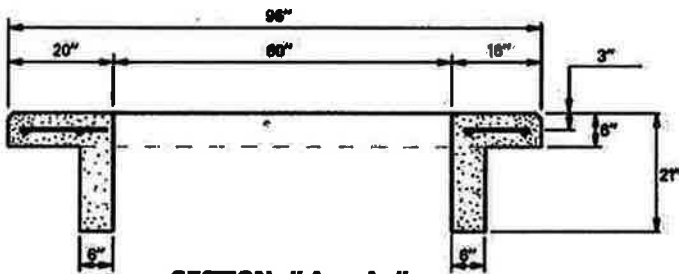

NOTES:

1. SEE DETAIL SHEET 21 FOR GENERAL NOTES.
2. CONTRACTOR TO OBTAIN AND INSTALL (2) 5/8" X 10' GROUND RODS AS SHOWN. INSTALLATION DEPTH SHALL BE 7' - 6".
3. PIERS ARE REQUIRED ON ALL THREE PHASE TRANSFORMER PADS UNLESS WAIVED BY THE COMPANY INSPECTOR. REFERENCE DETAIL SHEET 22 FOR PIER DETAILS.
4. BEGIN SECONDARY CONDUITS AT RIGHT EDGE OF PAD WINDOW. ADD CONDUITS AS REQUIRED RIGHT TO LEFT. DO NOT CROSS DIVIDING LINE BETWEEN PRIMARY AND SECONDARY COMPARTMENTS.
5. GROUT WINDOW AS PER DETAIL SHEET 16.



**TRANSFORMER PAD
THREE PHASE 225 - 500 KVA
LIVE FRONT LOOP FEED**

DDS-4 UG DETAIL SHEET 32 OF 57

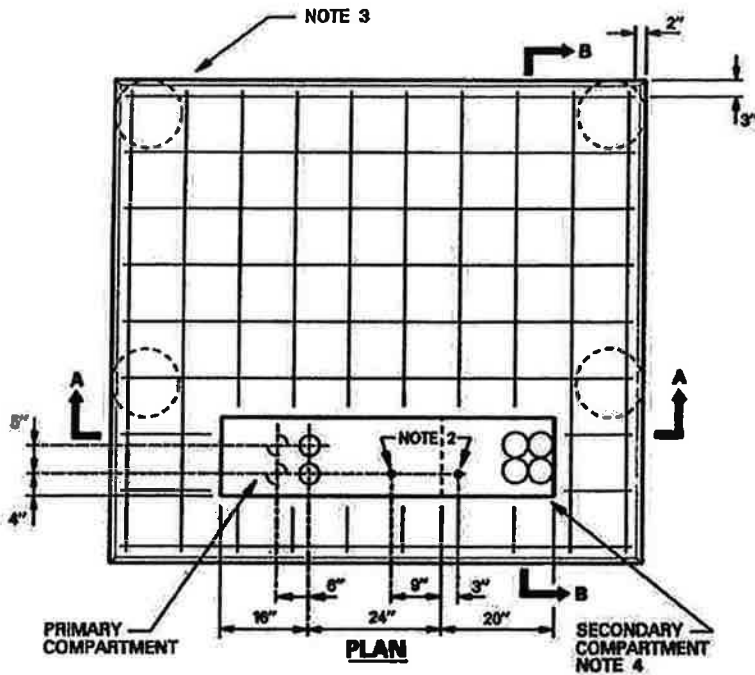

REINFORCEMENT SPACING: 10" CENTERS

REINFORCING SCHEDULE PAD WITH BEAMS (NOTES 4 & 5)		
NUMBER OF #3 BARS	LENGTH	WEIGHT (LBS)
6	82"	15.4
6	56"	10.5
6	8"	1.50
2	16"	1.00
2	12"	0.75
8	92"	25.9

2.00 CU YARDS CONCRETE
TOTAL WEIGHT OF PAD 7,840 LBS

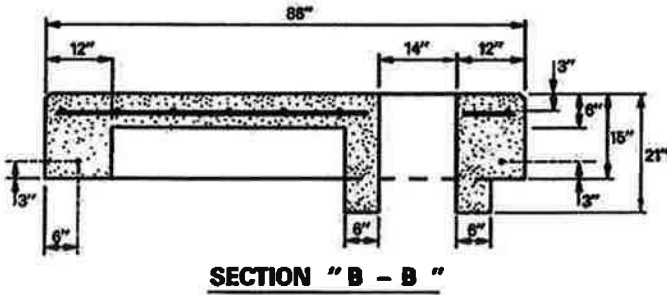
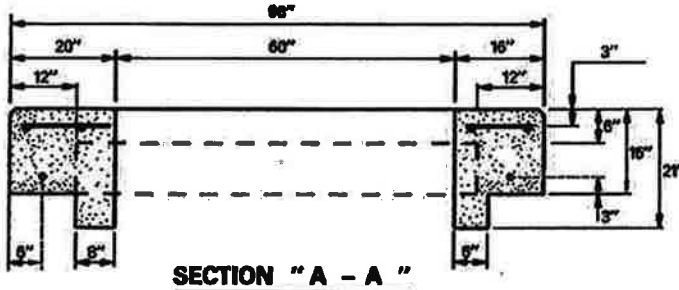

NOTES:

1. SEE DETAIL SHEET 21 FOR GENERAL NOTES.
2. CONTRACTOR TO OBTAIN AND INSTALL (2) 5/8" X 10' GROUND RODS AS SHOWN. INSTALLATION DEPTH SHALL BE 7' - 6".
3. PIERS ARE REQUIRED ON ALL THREE PHASE TRANSFORMER PADS UNLESS WAIVED BY THE COMPANY INSPECTOR. REFERENCE DETAIL SHEET 22 FOR PIER DETAILS.
4. BEGIN SECONDARY CONDUITS AT RIGHT EDGE OF PAD WINDOW. ADD CONDUITS AS REQUIRED RIGHT TO LEFT. DO NOT CROSS DIVIDING LINE BETWEEN PRIMARY AND SECONDARY COMPARTMENTS.
5. GROUT WINDOW AS PER DETAIL SHEET 16.



**TRANSFORMER PAD WITH BEAMS
THREE PHASE 225 - 500 KVA
LIVE FRONT LOOP FEED**

DDS-4 UG DETAIL SHEET 33 OF 57

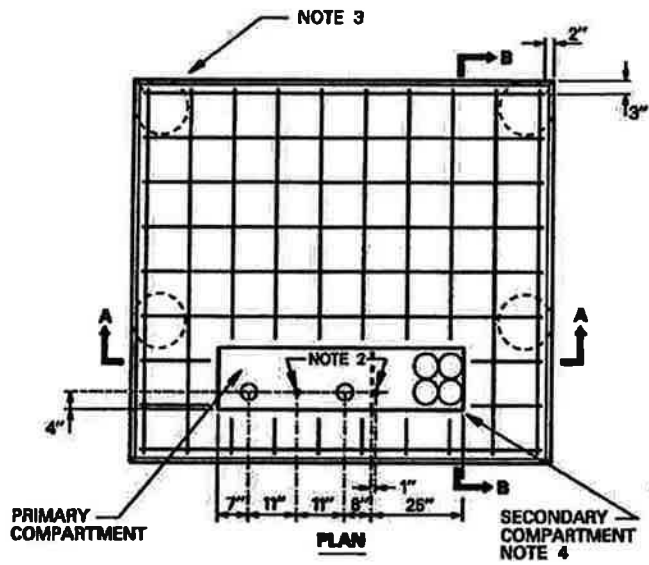

REINFORCEMENT SPACING: 10" CENTERS

REINFORCING SCHEDULE PAD WITHOUT BEAMS		
NUMBER OF #3 BARS	LENGTH	WEIGHT (LBS)
4	82"	10.3
6	56"	10.5
6	8"	1.5
4	13"	1.8
7	92"	20.2

1.34 CU YARDS CONCRETE
TOTAL WEIGHT OF PAD 5,270 LBS

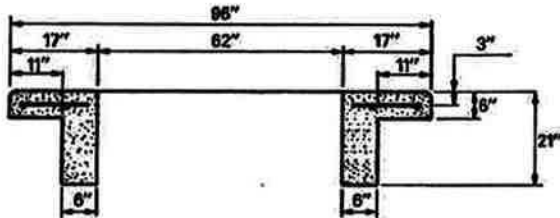

SECTION "A - A"

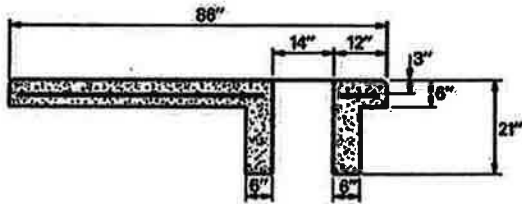

SECTION "B - B"

NOTES:

1. SEE DETAIL SHEET 21 FOR GENERAL NOTES.
2. CONTRACTOR TO OBTAIN AND INSTALL (2) 6/8" X 10' GROUND RODS AS SHOWN. INSTALLATION DEPTH SHALL BE 7' - 8'.
3. PIERS ARE REQUIRED ON ALL THREE PHASE TRANSFORMER PADS UNLESS WAIVED BY THE COMPANY INSPECTOR. REFERENCE DETAIL SHEET 22 FOR PIER DETAILS.
4. BEGIN SECONDARY CONDUITS AT RIGHT EDGE OF PAD WINDOW. ADD CONDUITS AS REQUIRED RIGHT TO LEFT. DO NOT CROSS DIVIDING LINE BETWEEN PRIMARY AND SECONDARY COMPARTMENTS.
5. GROUT WINDOW AS PER DETAIL SHEET 15.



**TRANSFORMER PAD
THREE PHASE 225 - 500 KVA
DEADFRONT LOOP FEED**

DDS-4 UG DETAIL SHEET 34 OF 57

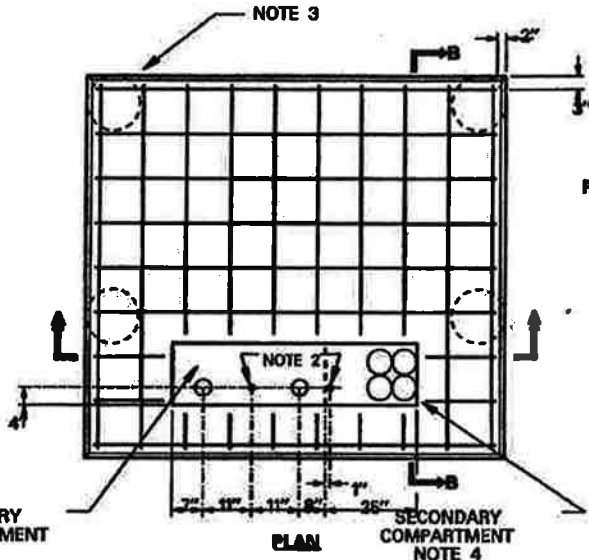

REINFORCEMENT SPACING: 10" CENTERS

REINFORCING SCHEDULE PAD WITH BEAMS (NOTES 4 & 5)		
NUMBER OF #3 BARS	LENGTH	WEIGHT (LBS)
6	82"	16.4
6	58"	10.5
6	8"	1.5
4	13"	1.6
9	92"	25.9

1.97 CU YARDS CONCRETE
TOTAL WEIGHT OF PAD 7,710 LBS

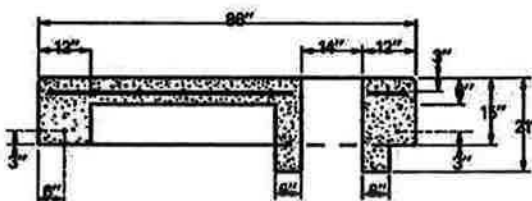
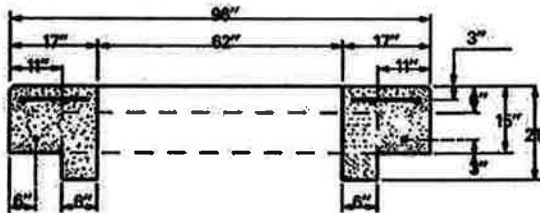

NOTES:

1. SEE DETAIL SHEET 21 FOR GENERAL NOTES.
2. CONTRACTOR TO OBTAIN AND INSTALL (2) 5/8" X 10' GROUND RODS AS SHOWN. INSTALLATION DEPTH SHALL BE 7'- 6".
3. PIERS ARE REQUIRED ON ALL THREE PHASE TRANSFORMER PADS UNLESS WAIVED BY THE COMPANY INSPECTOR. REFERENCE DETAIL SHEET 22 FOR PIER DETAILS.
4. BEGIN SECONDARY CONDUITS AT RIGHT EDGE OF PAD WINDOW. ADD CONDUITS AS REQUIRED RIGHT TO LEFT. DO NOT CROSS DIVIDING LINE BETWEEN PRIMARY AND SECONDARY COMPARTMENTS.
5. GROUT WINDOW AS PER DETAIL SHEET 15.



**TRANSFORMER PAD WITH BEAMS
THREE PHASE 225 - 500 KVA
DEADFRONT LOOP FEED**

DDS-4 UG DETAIL SHEET 35 OF 57

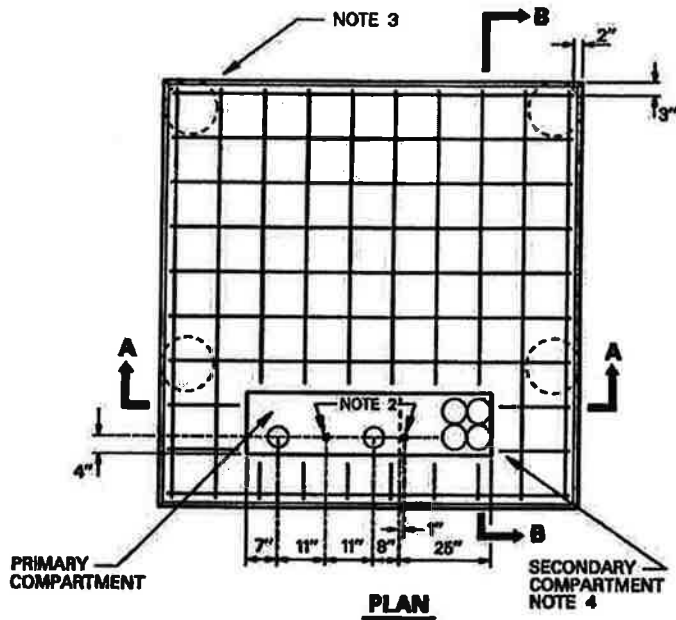

REINFORCEMENT SPACING: 10" CENTERS

REINFORCING SCHEDULE PAD WITHOUT BEAMS		
NUMBER OF #3 BARS	LENGTH	WEIGHT (LBS)
12	92"	34.5
6	8"	1.5
6	66"	12.4
4	13"	1.6

1.47 CU YARDS CONCRETE
TOTAL WEIGHT OF PAD 6,770 LBS

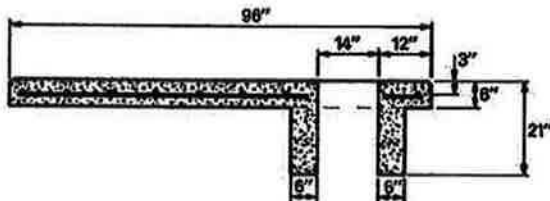
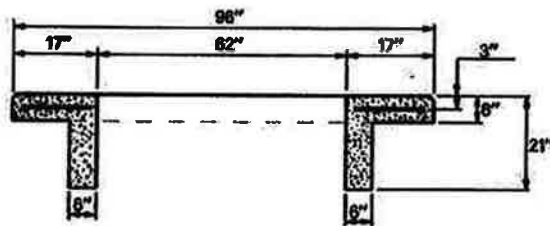

NOTES:

1. SEE DETAIL SHEET 21 FOR GENERAL NOTES.
2. CONTRACTOR TO OBTAIN AND INSTALL (2) 5/8" X 10' GROUND RODS AS SHOWN. INSTALLATION DEPTH SHALL BE 7'-6".
3. PIERS ARE REQUIRED ON ALL THREE PHASE TRANSFORMER PADS UNLESS WAIVED BY THE COMPANY INSPECTOR. REFERENCE DETAIL SHEET 22 FOR PIER DETAILS.
4. BEGIN SECONDARY CONDUITS AT RIGHT EDGE OF PAD WINDOW. ADD CONDUITS AS REQUIRED RIGHT TO LEFT. DO NOT CROSS DIVIDING LINE BETWEEN PRIMARY AND SECONDARY COMPARTMENTS.
5. GROUT WINDOW AS PER DETAIL SHEET 15.



**TRANSFORMER PAD
THREE PHASE 750 KVA
DEADFRONT LOOP FEED**

DDS-4 UG DETAIL SHEET 36 OF 57

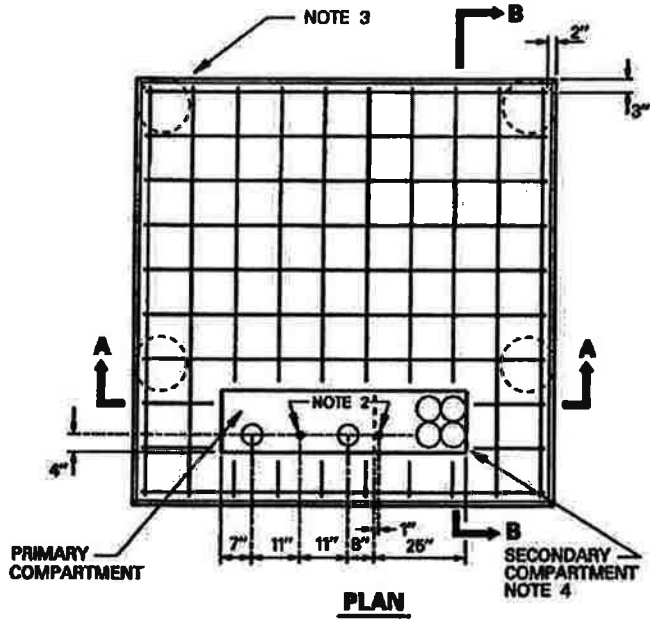

REINFORCEMENT SPACING: 10" CENTERS

REINFORCING SCHEDULE PAD WITH BEAMS (NOTES 4 & 5)		
NUMBER OF #3 BARS	LENGTH	WEIGHT (LBS)
18	92"	46.0
6	8"	1.5
6	66"	12.4
4	13"	1.6

2.14 CU YARDS CONCRETE
TOTAL WEIGHT OF PAD 8,360 LBS

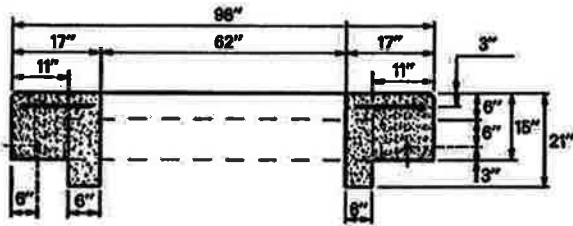

SECTION "A - A"

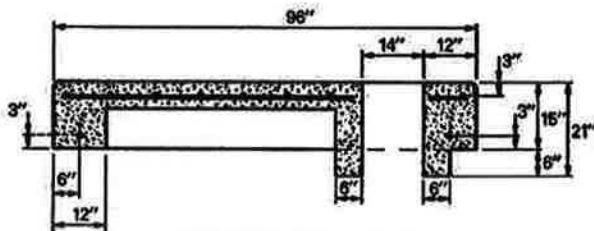

SECTION "B - B"

NOTES:

1. SEE DETAIL SHEET 21 FOR GENERAL NOTES.
2. CONTRACTOR TO OBTAIN AND INSTALL (2) 5/8" X 10' GROUND RODS AS SHOWN. INSTALLATION DEPTH SHALL BE 7'-6".
3. PIERS ARE REQUIRED ON ALL THREE PHASE TRANSFORMER PADS UNLESS WAIVED BY THE COMPANY INSPECTOR. REFERENCE DETAIL SHEET 22 FOR PIER DETAILS.
4. BEGIN SECONDARY CONDUITS AT RIGHT EDGE OF PAD WINDOW. ADD CONDUITS AS REQUIRED RIGHT TO LEFT. DO NOT CROSS DIVIDING LINE BETWEEN PRIMARY AND SECONDARY COMPARTMENTS.
5. GROUT WINDOW AS PER DETAIL SHEET 15.



**TRANSFORMER PAD WITH BEAMS
THREE PHASE 750 KVA
DEADFRONT LOOP FEED**

DDS-4 UG DETAIL SHEET 37 OF 57

Three-Phase Transformer Size (kVA)	Maximum Number of 4" PVC Conduits		Maximum Number of Cables Including the Neutral	
	208Y/120	480Y/277	208Y/120	480Y/277
75 – 150	6	6	24	24
225 – 300	6	6	24	24
500	8	6	32	24
750	12	6	48	24
1000	16	8	64	32
1500	–	12	–	48
2000	–	16	–	64
2500	–	16	–	64

Notes:

1. For three-phase padmount transformers, the customer's service conductor must be 1000 kcmil or smaller. The maximum number of runs (three phase conductors and one neutral conductor) shall be as shown in above table.
2. For single-phase 240/120 volt transformers, the customer's service conductor must be 500 kcmil or smaller. The maximum number of runs (two phase conductors and one neutral conductor) and the size of the conduits shall be as shown in the following table:

Customer's Conductor Size	Conduit Sizes	Maximum Number of Runs
#8 – #3/0	2"	8
#4/0 – 350 kcmil	3"	6
500 kcmil	4"	4

3. If the number of runs installed by the customer is more than the maximum shown, a connection enclosure with pad may be required. Consult company representative for details.



**MAXIMUM NUMBER OF SECONDARY
CONDUITS AND CABLES
FOR PADMOUNTED TRANSFORMERS**

DDS-4 UG DETAIL SHEET 38 OF 57

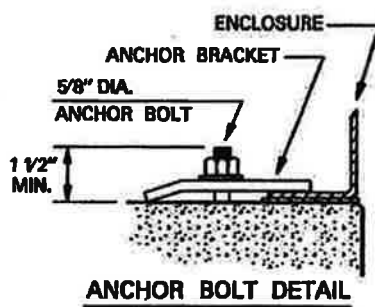
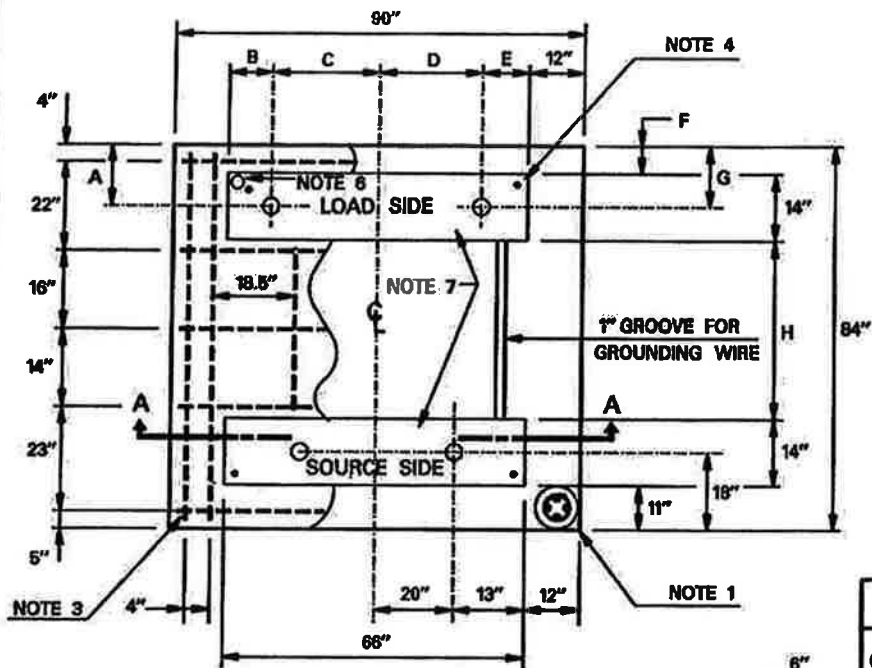

REINFORCING SCHEDULE		
NUMBER OF #3 BARS	LENGTH	WEIGHT (LBS)
5	86"	13.5
4	80"	10.0
3	33"	3.1

TOTAL WEIGHT (CONCRETE & REBAR) 5280 LBS.

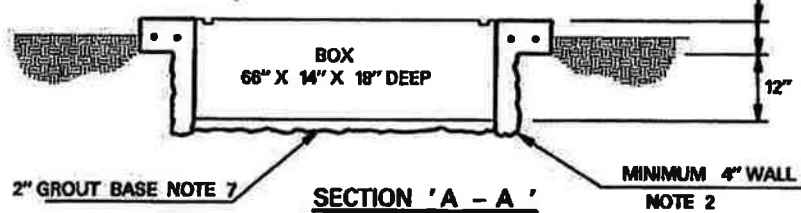

25KV	A	B	C	D	E	F	G	H
PMH - 9	15"	11"	22"	22"	11"	8"	15"	37"
PMH - 10	18"	13"	20"	20"	13"	11"	18"	34"
PMH - 11	15"	11"	22"	20"	13"	8"	18"	37"

NOTES:

1. PIERS ARE REQUIRED ON ALL SWITCHGEAR PADS UNLESS WAIVED BY THE COMPANY INSPECTOR. REFERENCE DETAIL SHEET 23 FOR PIER DETAIL.
2. USE WIRE MESH FOR CONCRETE REINFORCEMENT AROUND DEEPWELL BOX.
3. ENDS OF RE-BAR SHALL REMAIN A MINIMUM OF 2" INSIDE OF CONCRETE AND SHALL BE INTERMEDIATE GRADE 60 AND CONFORM TO ASTM A615.
4. CONTACT COMPANY REPRESENTATIVE ON WHERE TO OBTAIN 5/8" X 10' COPPER CLAD GROUND RODS. GROUND RODS TO BE OBTAINED AND INSTALLED BY CONTRACTOR. INSTALLATION DEPTH SHALL BE 7' - 8'.
5. FOR CLEARANCES ON ALL SIDES OF THE SWITCHGEAR REFERENCE DETAIL SHEETS 51, 52, 53 AND 54.
6. FOR PADS PLUMBED INTO DUCT BANKS, INSTALL 3" COMMUNICATION CONDUIT FROM MANHOLE TO FRONT RIGHT CORNER OF LOAD SIDE CONDUIT OPENING OF PAD.
7. GROUT AS PER DETAIL SHEET 15.



**CONCRETE PAD
POURED IN PLACE
25 KV LIVE FRONT SWITCHGEAR
DDS-4 UG DETAIL SHEET 39 OF 57**

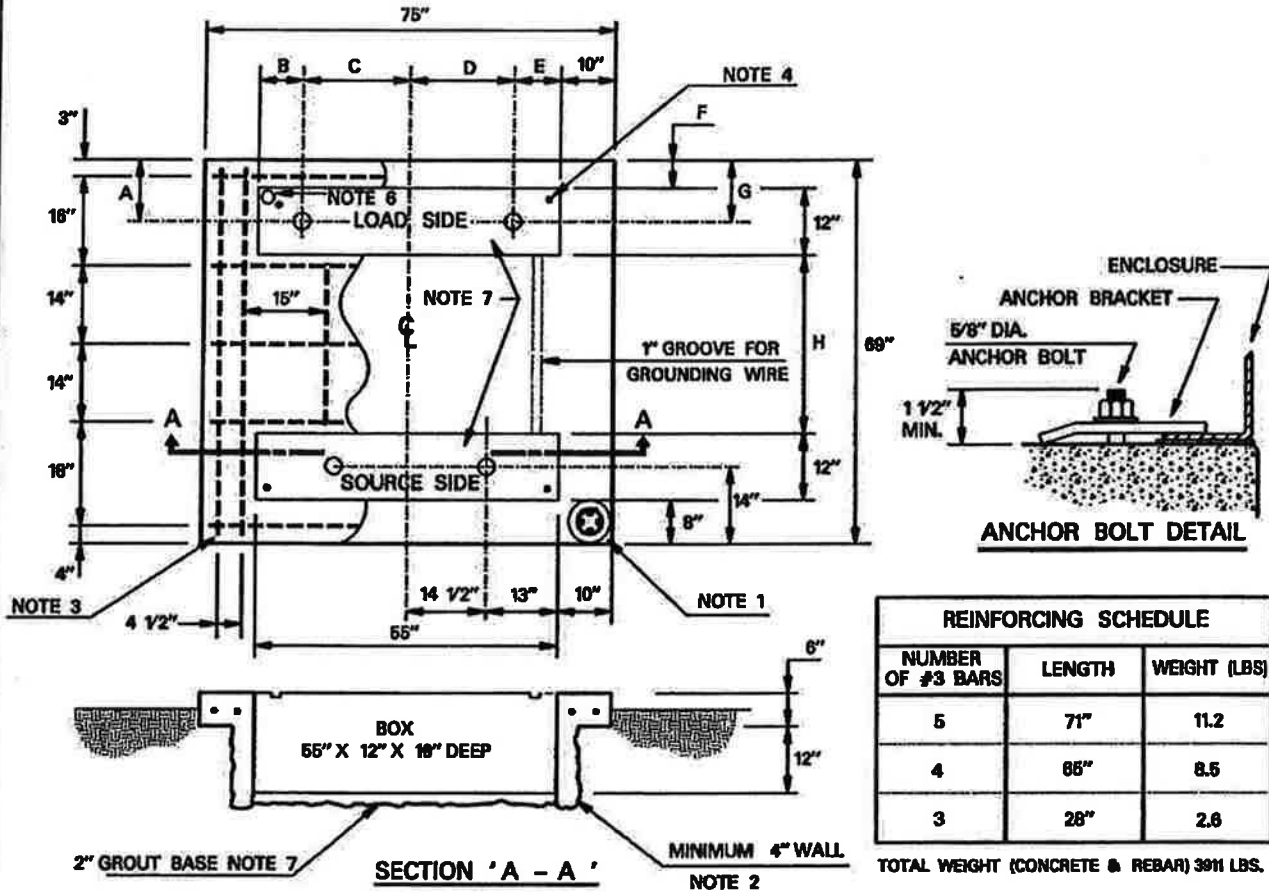

REINFORCING SCHEDULE		
NUMBER OF #3 BARS	LENGTH	WEIGHT (LBS)
5	71"	11.2
4	65"	8.5
3	28"	2.6

TOTAL WEIGHT (CONCRETE & REBAR) 3911 LBS.

15KV	A	B	C	D	E	F	G	H
PMH - 9	11"	8.5"	19"	19"	8.5"	5"	11"	32"
PMH - 10	13"	13"	14.5"	14.5"	13"	7"	13"	30"
PMH - 11	11"	8.5"	19"	14.5"	13"	5"	11"	32"

NOTES:

1. PIERS ARE REQUIRED ON ALL SWITCHGEAR PADS UNLESS WAIVED BY THE COMPANY INSPECTOR. REFERENCE DETAIL SHEET 23 FOR PIER DETAIL.
2. USE WIRE MESH FOR CONCRETE REINFORCEMENT AROUND DEEPWELL BOX.
3. ENDS OF RE-BAR SHALL REMAIN A MINIMUM OF 2" INSIDE OF CONCRETE AND SHALL BE INTERMEDIATE GRADE 60 AND CONFORM TO ASTM A615.
4. CONTACT COMPANY REPRESENTATIVE ON WHERE TO ACQUIRE 5/8" X 10' COPPER CLAD GROUND RODS. GROUND RODS TO BE OBTAINED AND INSTALLED BY CONTRACTOR. INSTALLATION DEPTH SHALL BE 7' - 6".
5. FOR CLEARANCES ON ALL SIDES OF THE SWITCHGEAR REFERENCE DETAIL SHEETS 61 62, 63 AND 64.
6. FOR PADS PLUMBED INTO DUCT BANKS, INSTALL 3" COMMUNICATION CONDUIT FROM MANHOLE TO FRONT RIGHT CORNER OF LOAD SIDE CONDUIT OPENING OF PAD.
7. GROUT AS PER DETAIL SHEET 15.



**CONCRETE PAD
POURED IN PLACE
15 KV LIVE FRONT SWITCHGEAR
DDS-4 UG DETAIL SHEET 40 OF 57**

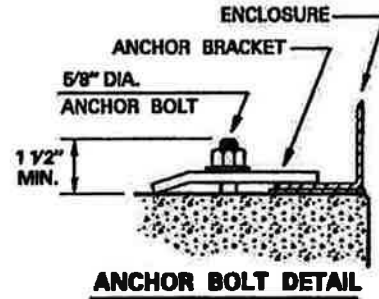
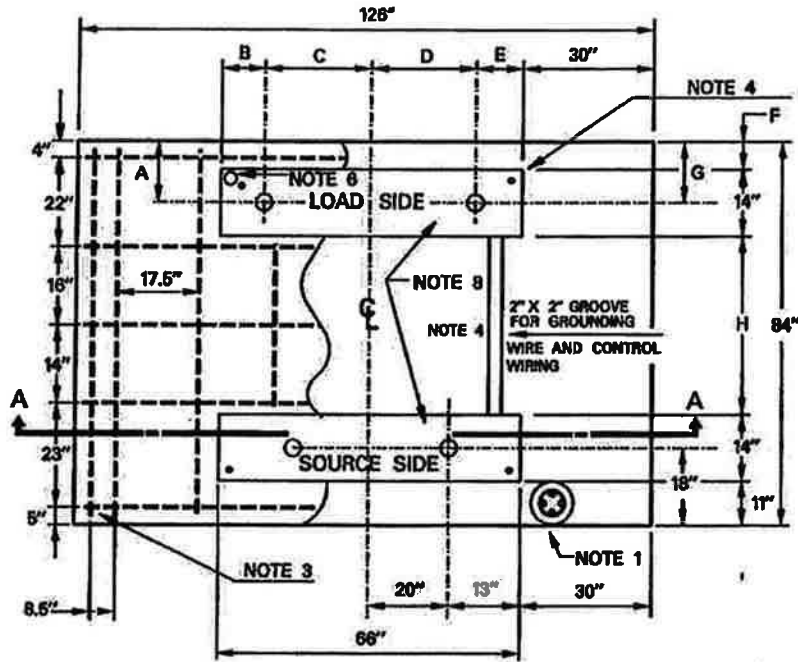

REINFORCING SCHEDULE		
NUMBER OF #3 BARS	LENGTH	WEIGHT (LBS)
5	122"	19.1
6	80"	15.0
3	33"	3.1

TOTAL WEIGHT (CONCRETE & REBAR) 7040 LBS.

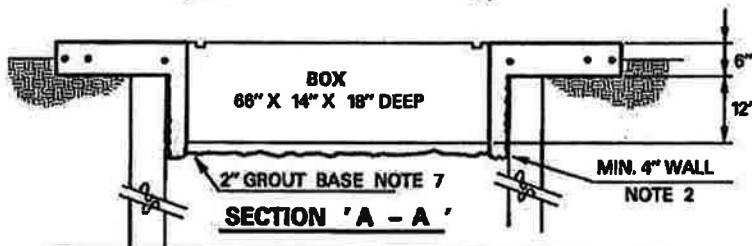

25KV	A	B	C	D	E	F	G	H
PMH - 9	16"	11"	22"	22"	11"	8"	15"	37"
PMH - 10	18"	13"	20"	20"	13"	11"	18"	34"
PMH - 11	15"	11"	22"	20"	13"	8"	18"	37"

NOTES:

- PIERS ARE REQUIRED ON ALL SWITCHGEAR PADS UNLESS WAIVED BY THE COMPANY INSPECTOR. REFERENCE DETAIL SHEET 23 FOR PIER DETAIL.
- USE WIRE MESH FOR CONCRETE REINFORCEMENT AROUND DEEPWELL BOX.
- ENDS OF RE-BAR SHALL REMAIN A MINIMUM OF 2" INSIDE OF CONCRETE AND SHALL BE INTERMEDIATE GRADE 60 AND CONFORM TO ASTM A615.
- CONTACT COMPANY REPRESENTATIVE ON WHERE TO ACQUIRE 5/8" X 10' COPPER CLAD GROUND RODS. GROUND RODS TO BE OBTAINED AND INSTALLED BY CONTRACTOR. INSTALLATION DEPTH SHALL BE 7' - 6".
- FOR CLEARANCES ON ALL SIDES OF THE SWITCHGEAR SEE DETAIL SHEETS 51, 52, 53 AND 54.
- FOR PADS PLUMBED INTO DUCT BANKS, INSTALL 3" COMMUNICATION CONDUIT FROM MANHOLE TO FRONT RIGHT CORNER OF LOAD SIDE CONDUIT OPENING OF PAD.
- GROUT AS PER DETAIL SHEET 15.



**CONCRETE PAD POURED IN PLACE
25 KV LIVE FRONT AUTOMATED
SUPERVISORY CONTROL SWITCHGEAR
DDS-4 UG DETAIL SHEET 41 OF 57**

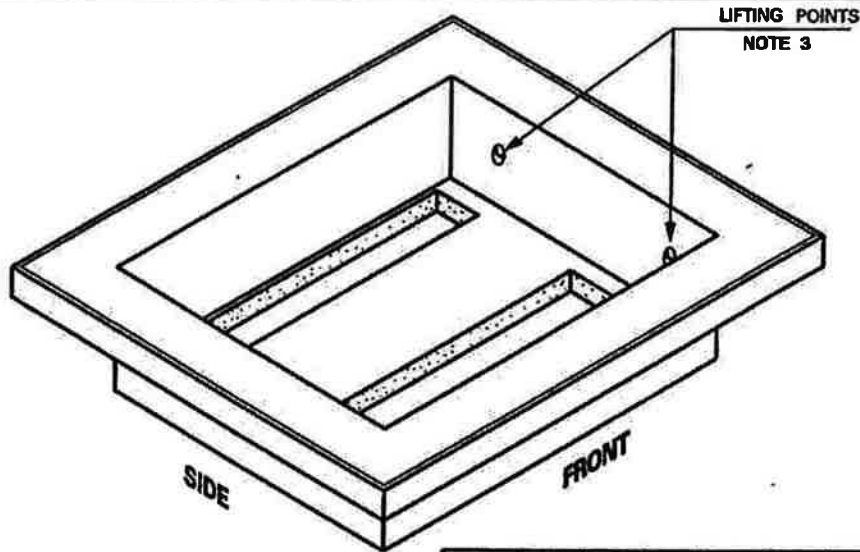

INCHES	A	B	C	D	E	E2	F	G	G2	W	X
25KV	100	76	62	88	40	19	48	44	16	68	15
15KV	84	60	50	74	30	15	36	38	11	52	15

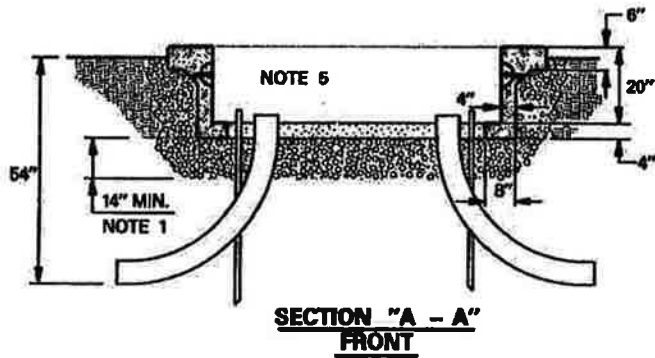
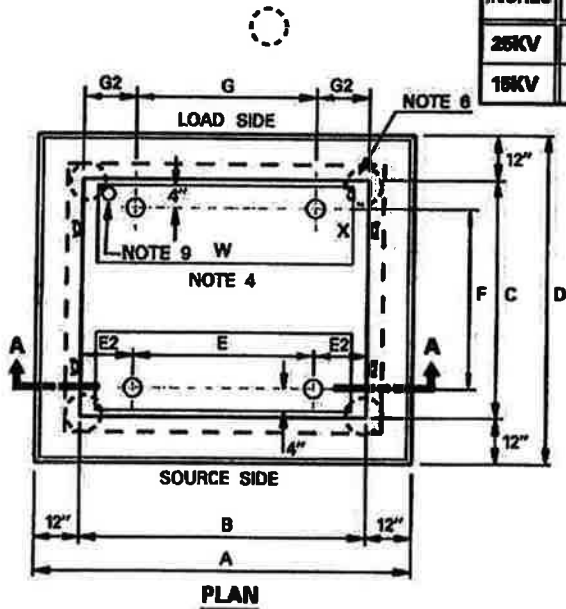

NOTES:

1. INSTALL 14" MINIMUM SMALL TO MEDIUM GRAVEL BASE. INCLUDE MINIMUM 12" GRAVEL FILL AROUND SIDES.
2. FOR CLEARANCES ON ALL SIDES OF THE SWITCHGEAR SEE DETAIL SHEETS 51, 52, 53, AND 54.
3. EACH PAD WILL INCLUDE FOUR - LIFTING POINTS RATED AT 2000 LBS EACH.
4. WHEN INSTALLING SPARE CONDUIT, CENTER DIMENSION LINES BETWEEN CONDUITS.
5. CONDUIT NOT TO EXTEND MORE THAN 3" ABOVE BOTTOM OF DEEPWELL.
6. CONTACT COMPANY REPRESENTATIVE ON WHERE TO ACQUIRE 5/8" X 10' COPPER CLAD GROUND RODS. GROUND RODS TO BE OBTAINED AND INSTALLED BY CONTRACTOR. INSTALLATION DEPTH SHALL BE 7' - 8'.
7. CONTACT COMPANY REPRESENTATIVE ON WHERE TO ACQUIRE PRECAST CONCRETE PAD.
8. PIERS ARE REQUIRED ON ALL PADS UNLESS WAIVED BY THE COMPANY INSPECTOR. REFERENCE DETAIL SHEET 23 FOR PIER DETAIL.
9. FOR PADS PLUMBED INTO DUCT BANKS, INSTALL 3" COMMUNICATION CONDUIT FROM MANHOLE TO FRONT RIGHT CORNER OF LOAD SIDE CONDUIT OPENING OF PAD.



**PRECAST DEEPWELL PAD
25 KV / 15 KV
LIVE FRONT SWITCHGEAR**

DDS-4 UG DETAIL SHEET 42 OF 57

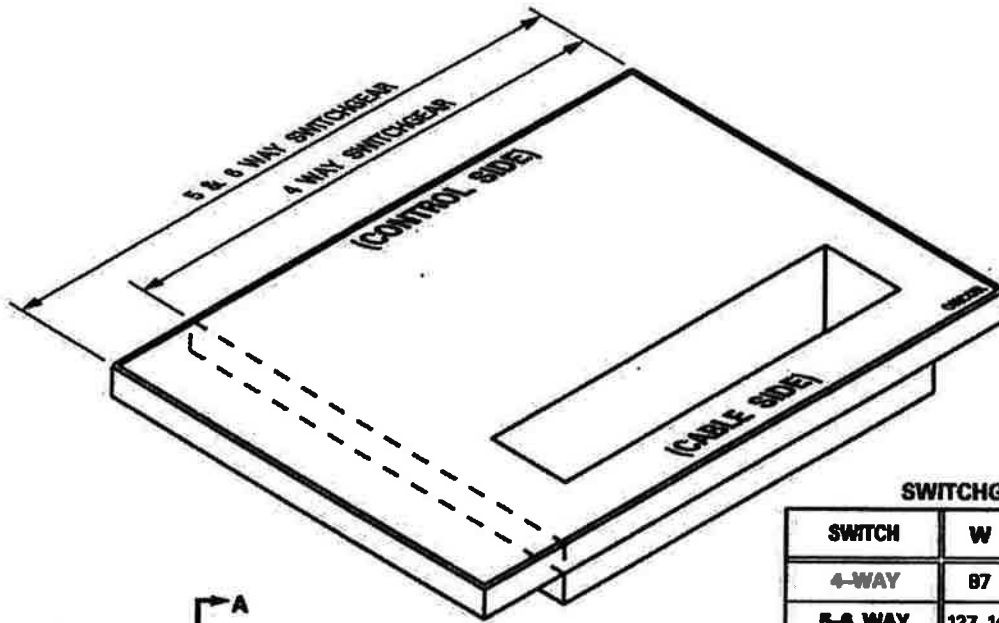

SWITCHGEAR WAYS

SWITCH	W	B	D	WEIGHT
4-WAY	87	64	75	3750LBS
5-6 WAY	127 1/2	94	75	
4-5 WAY ATO	127 1/2	94	75	5465LBS
4-5 WAY RSC	127 1/2	94	75	

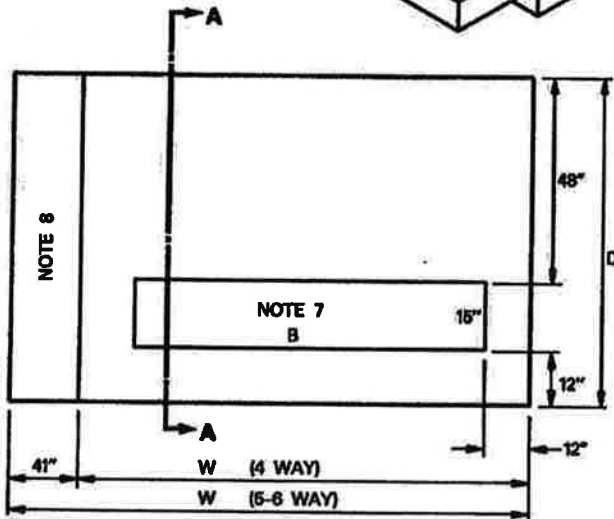

PLAN

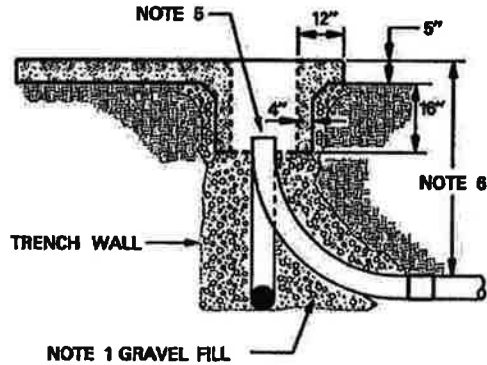

SECTION "A - A"

NOTES:

1. FOR STABILIZATION AND DRAINAGE INSTALL SMALL TO MEDIUM GRAVEL UNDER PAD DEEP WELL.
2. FOR CLEARANCES ON ALL SIDES OF THE SWITCHGEAR SEE DETAIL SHEETS 51, 52, 53 AND 54.
3. PIERS ARE REQUIRED ON ALL PADS UNLESS WAIVED BY THE COMPANY INSPECTOR. REFERENCE DETAIL SHEET 23 FOR PIER DETAIL.
4. LIFT PAD WITH PROVIDED LIFTING POINTS ONLY. SEE LIFTING RINGS INSIDE WALL OF DEEP WELL.
5. CONDUIT NOT TO EXTEND MORE THAN 3" ABOVE BOTTOM OF DEEP WELL.
6. MINIMUM TRENCH DEPTH AT PAD TO TOP OF CONDUIT FOR THE FOLLOWING CONDUITS:
 - 6" CONDUIT — 61"
 - 4" CONDUIT — 47"
 - 2" CONDUIT — 40"
7. REFER TO DETAIL SHEET 44 FOR CONDUIT LOCATIONS.
8. ADDITIONAL AREA FOR CONTROL CABINET WHEN MOUNTING REMOTE SUPERVISORY CONTROLLED SWITCHGEAR.
9. CONTACT COMPANY REPRESENTATIVE ON WHERE TO ACQUIRE 5/8" X 10' COPPER CLAD GROUND RODS. GROUND RODS TO BE OBTAINED AND INSTALLED BY CONTRACTOR. INSTALLATION DEPTH SHALL BE 7' - 8'.
10. CONTACT COMPANY REPRESENTATIVE ON WHERE TO ACQUIRE PRECAST CONCRETE PAD.



**PRECAST DEEPWELL PAD
FOR 25 KV DEADFRONT
SWITCHGEAR**

DDS-4 UG DETAIL SHEET 43 OF 57

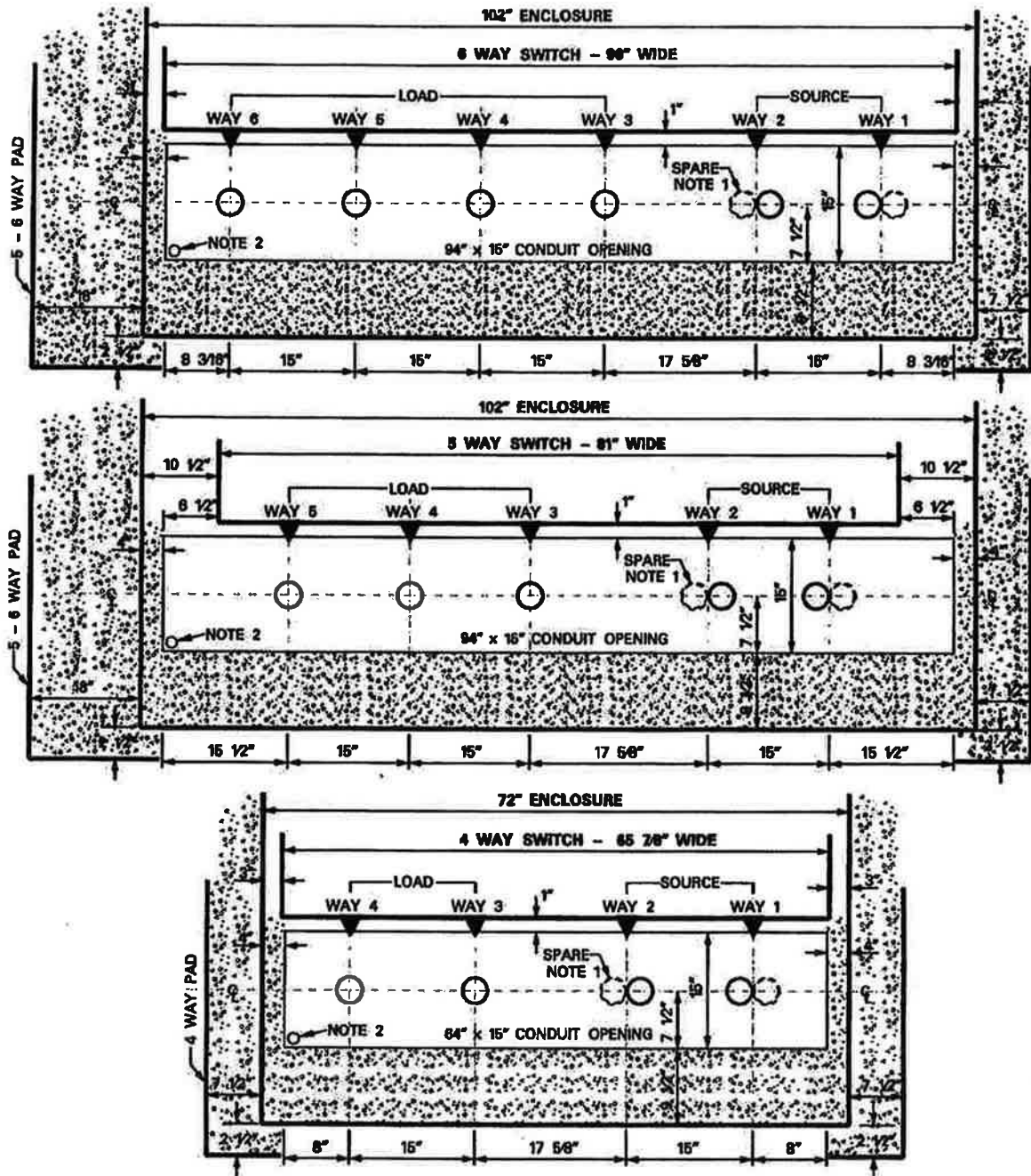

NOTE:

1. CONDUIT SHALL BE CENTERED ON CENTER BUSHING OF EACH SWITCHED WAY. IF SPARE CONDUIT IS REQUIRED, BOTH SHALL BE CENTERED AS SHOWN ON CENTER BUSHING OF SWITCHED WAY.
2. FOR PADS PLUMBED INTO DUCT BANKS, INSTALL 3" COMMUNICATION CONDUIT FROM MANHOLE TO FRONT LEFT CORNER OF THE CONDUIT OPENING OF PAD.



**CONDUIT LOCATIONS
DEAD FRONT PADMOUNT
25 KV VISTA SWITCHGEAR**

DDS-4 UG DETAIL SHEET 44 OF 57

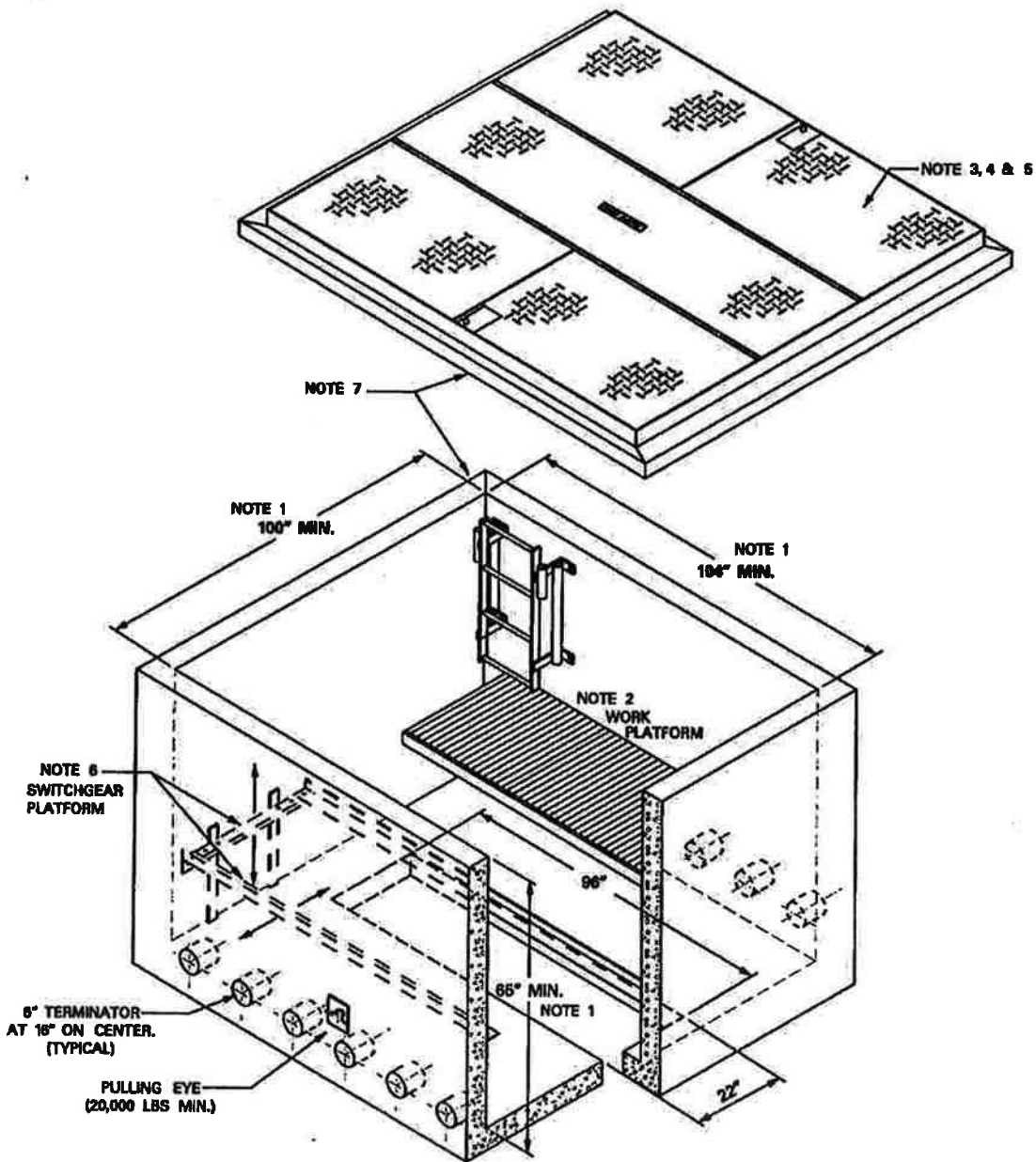

NOTE:

1. ALL DIMENSIONS SHOWN ARE MINIMUM INSIDE MEASUREMENTS. CONTACT DISTRIBUTION STANDARDS FOR ACTUAL MFG. DIMENSIONS.
2. LADDER, PLATFORMS, SUPPORT ANGLES AND COVER ARE PRE-INSTALLED.
3. STEEL DIAMOND PLATE TORSION ASSISTED COVERS.
4. VERTICAL LOADS TO COVER SHALL NOT EXCEED 18,000 LBS LIVE WHEEL WEIGHT.
5. VAULTS SHALL NOT BE INSTALLED IN LOCATIONS DESIGNATED ACCESSIBLE BY VEHICULAR TRAFFIC.
6. ADJUSTABLE SWITCHGEAR PLATFORM FOR 4- 6 WAY SWITCHGEAR.
7. FOR CLEARANCES ON ALL SIDES OF THE SWITCHGEAR SEE DETAIL SHEETS 51, 52, 53 & 54.
8. CONTACT COMPANY REPRESENTATIVE ON WHERE TO ACQUIRE 5/8" X 10' COPPER CLAD GROUND ROD. GROUND ROD TO BE OBTAINED AND INSTALLED BY CONTRACTOR. INSTALLATION DEPTH SHALL BE 7'- 8".
9. CONTACT COMPANY REPRESENTATIVE ON WHERE TO ACQUIRE PRECAST VAULT.



**PRECAST VAULT FOR
SUBSURFACE DEADFRONT
SWITCHGEAR**

DDS-4 UG DETAIL SHEET 45 OF 57

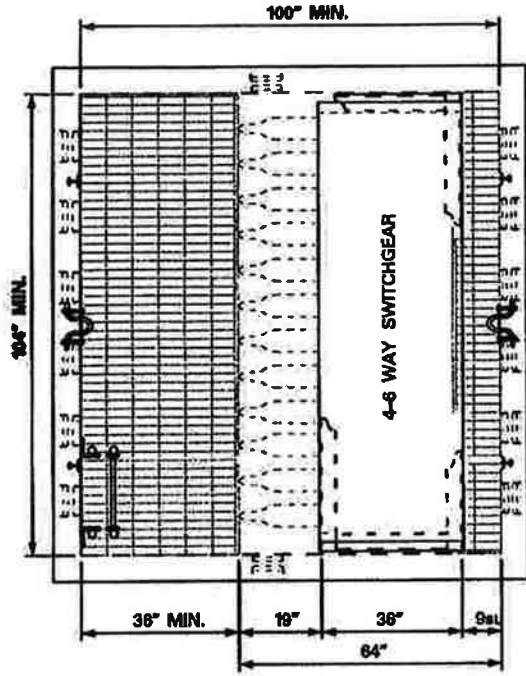

TOP VIEW

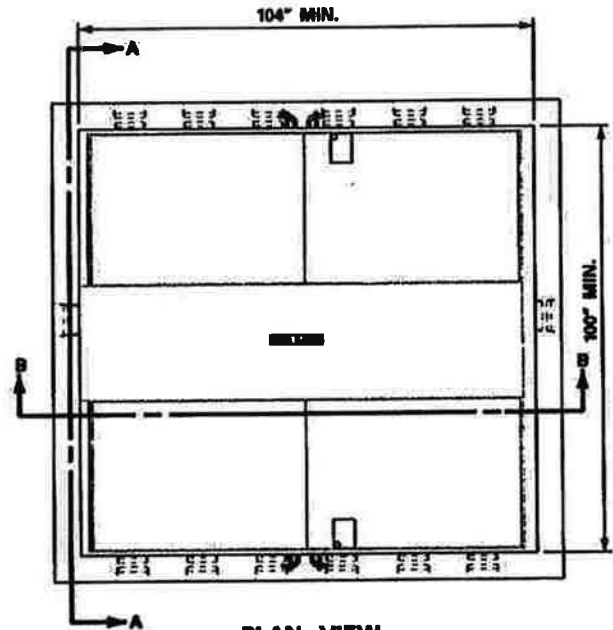

PLAN VIEW

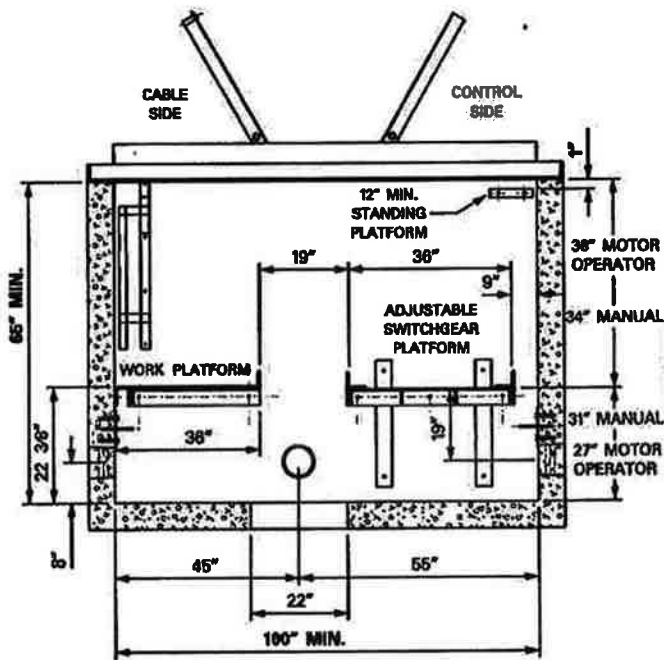

SECTION A-A

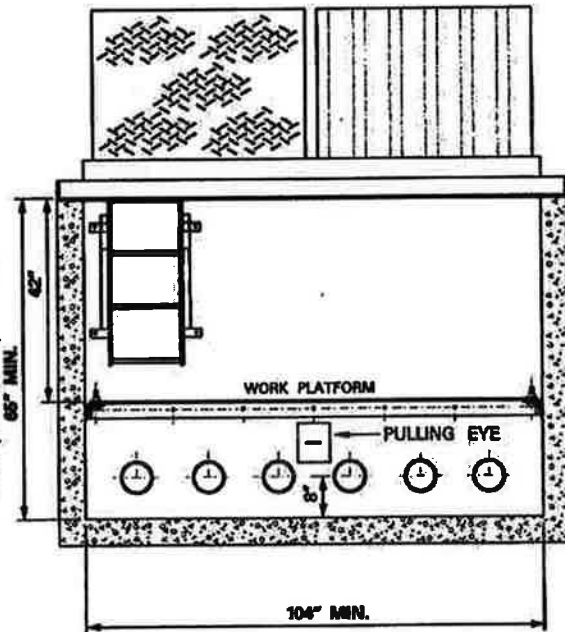

SECTION B-B
CROSS SUPPORT ANGLES NOT SHOWN



**PRECAST VAULT FOR
SUBSURFACE DEADFRONT
SWITCHGEAR**

DDS-4 UG DETAIL SHEET 46 OF 57

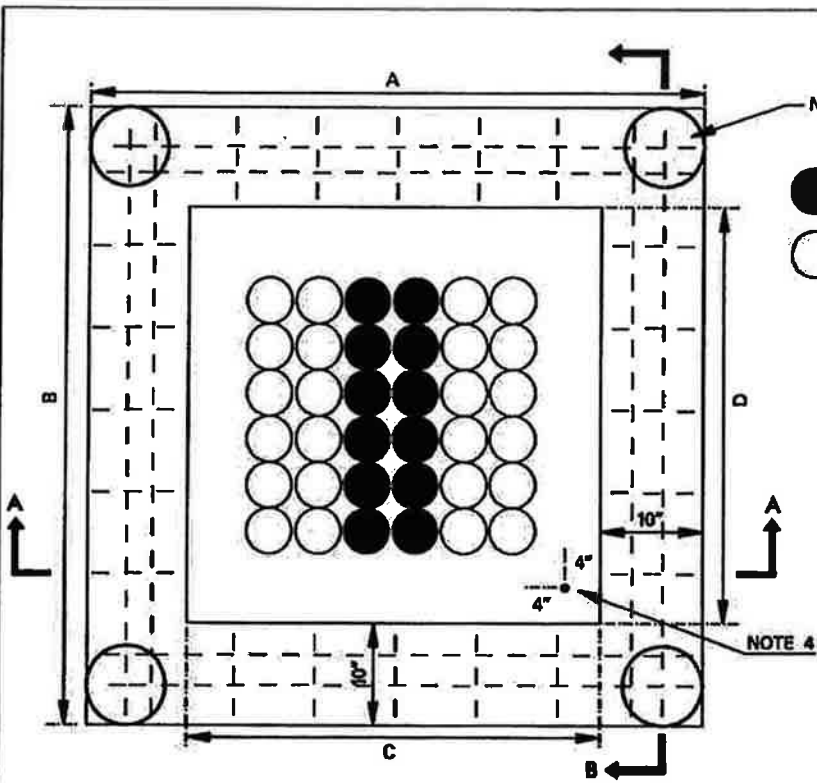

NOTE 3

- COMPANY OWNED CONDUITS - AS NEEDED - ALWAYS IN THE MIDDLE
- CUSTOMER OWNED CONDUITS - AS NEEDED

ENCLOSURE	DIMENSIONS			
OPENING SIZE	A	B	C	D
54 x 54	66"	66"	48"	46"

REINFORCING SCHEDULE 66 x 66		
NUMBER OF #3 BARS	LENGTH	WEIGHT (LBS)
18	62"	31.1
20	6"	3.8
4	8"	1.0

0.53 CU YARDS CONCRETE
TOTAL WEIGHT OF PAD 2170 LBS

NOTE 4

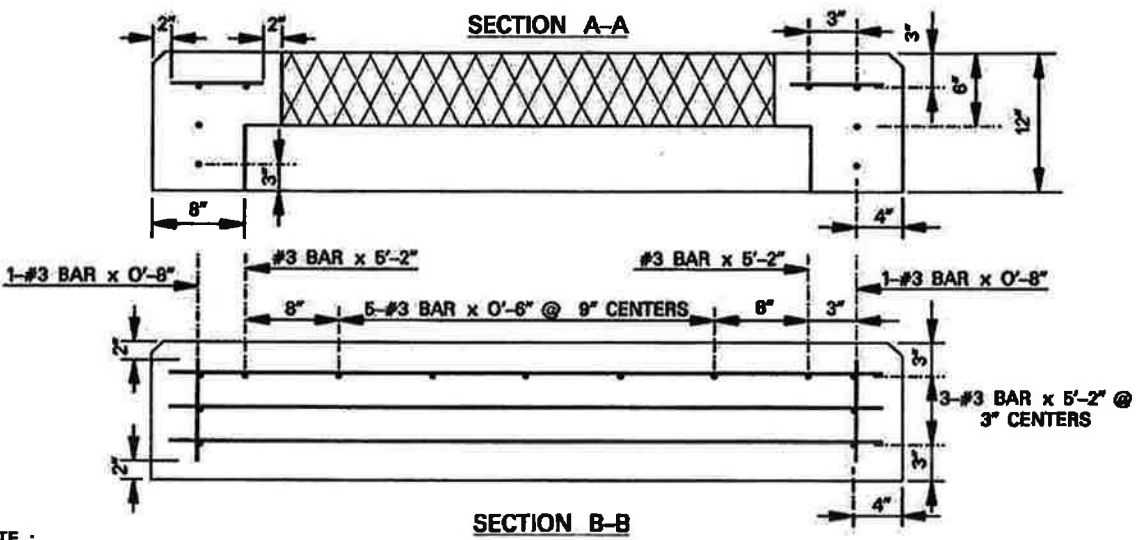

NOTE :

1. SEE SHEET 49 FOR ENCLOSURE DETAILS.
2. CONDUIT CONFIGURATION WILL DEPEND ON QUANTITY AND SIZE OF CONDUITS.
3. PIERS SHALL BE INSTALLED ON ALL PADS. REFERENCE SHEET 23 FOR PIER DETAIL.
4. CONTRACTOR TO OBTAIN AND INSTALL (1) 5/8" X 8" COPPER GROUND ROD AS SHOWN. INSTALLATION DEPTH SHALL BE 7" - 8".
5. REFERENCE SHEET 21 FOR ADDITIONAL NOTES.



**PAD DETAILS FOR
54" X 54"
SECONDARY ENCLOSURE**

DDS-4 UG DETAIL SHEET 47 OF 57

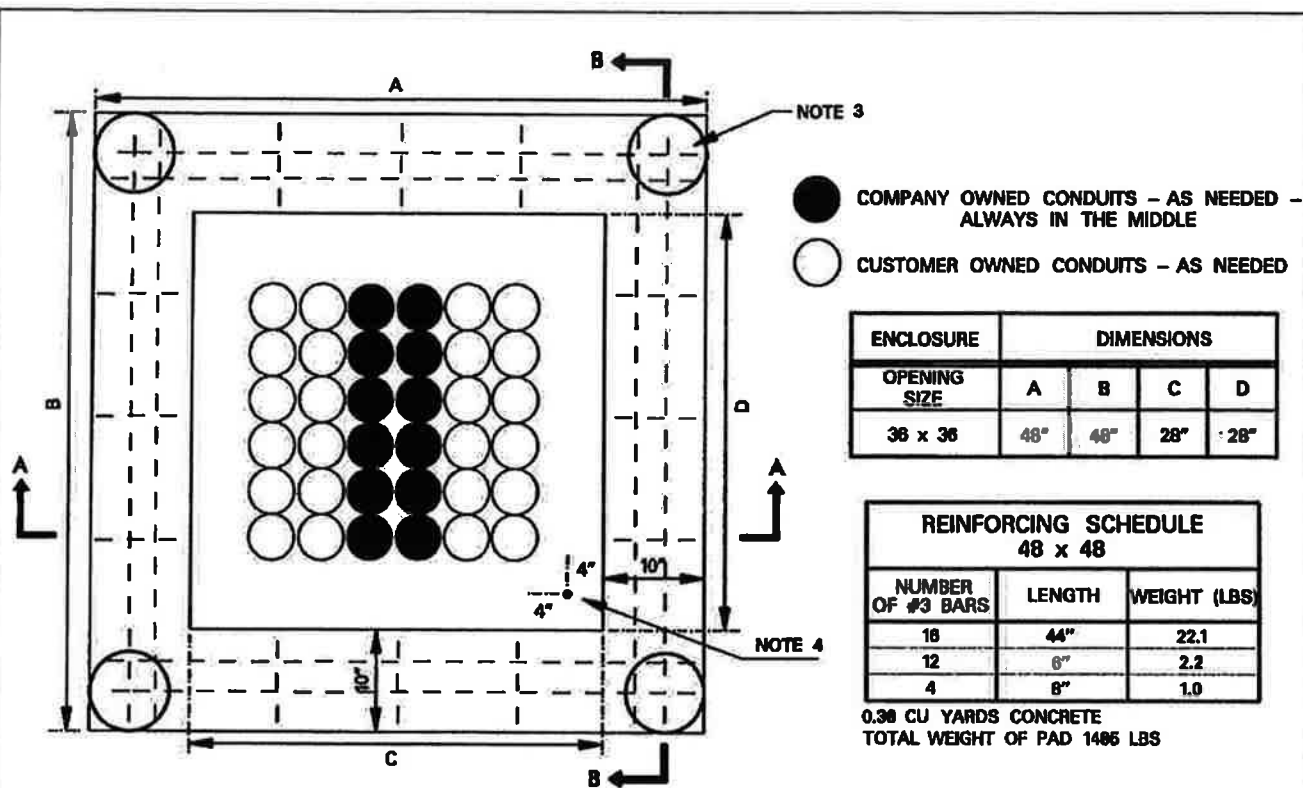

NOTE 3

- COMPANY OWNED CONDUITS - AS NEEDED - ALWAYS IN THE MIDDLE
- CUSTOMER OWNED CONDUITS - AS NEEDED

ENCLOSURE OPENING SIZE	DIMENSIONS			
	A	B	C	D
36 x 36	48"	48"	28"	28"

REINFORCING SCHEDULE 48 x 48		
NUMBER OF #3 BARS	LENGTH	WEIGHT (LBS)
18	44"	22.1
12	6"	2.2
4	8"	1.0

0.30 CU YARDS CONCRETE
TOTAL WEIGHT OF PAD 1485 LBS

NOTE 4

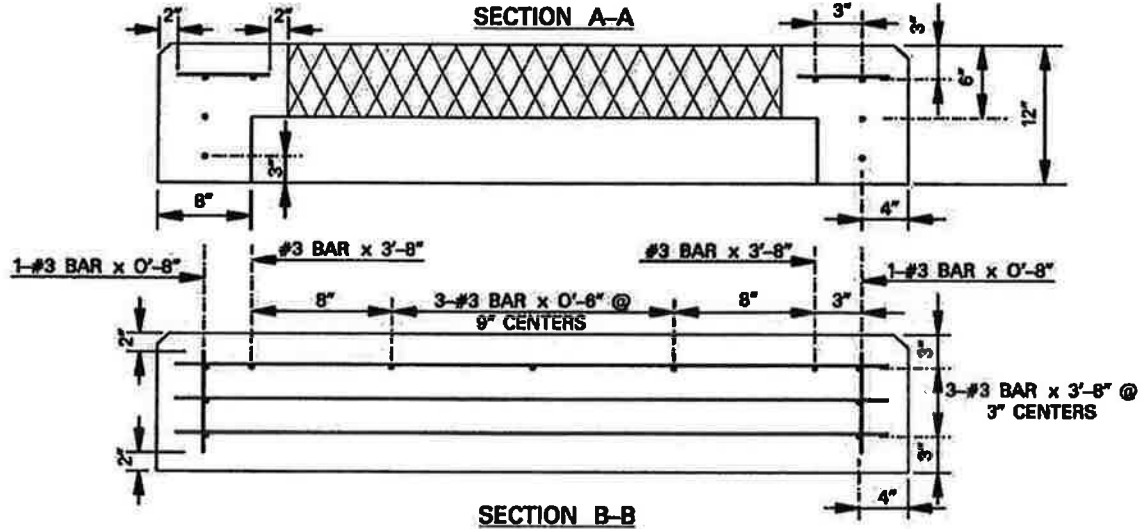

- NOTE :**
1. SEE SHEET 49 FOR ENCLOSURE DETAILS.
 2. CONDUIT CONFIGURATION WILL DEPEND ON QUANTITY AND SIZE OF CONDUITS.
 3. PIERS SHALL BE INSTALLED ON ALL PADS. REFERENCE SHEET 23 FOR PIER DETAIL.
 4. CONTRACTOR TO OBTAIN AND INSTALL (1) 5/8" X 8" COPPER GROUND ROD AS SHOWN. INSTALLATION DEPTH SHALL BE 7'- 8".
 5. REFERENCE SHEET 21 FOR ADDITIONAL NOTES.



**PAD DETAILS FOR
36" X 36"
SECONDARY ENCLOSURE**

DDS-4 UG DETAIL SHEET 48 OF 57

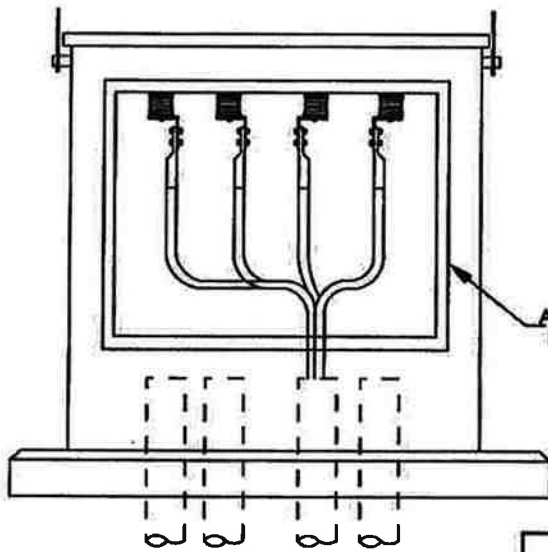

FRONT VIEW



**ANCHOR BOLT
DETAIL**

ACCESS DOORS ON
FRONT AND REAR

SPECIFICATIONS			
SIZE	NORMAL RATING	CENTER TAP RATING	SETS OF HOLES
36 x 36	2000 AMPS	3500 AMPS	18
54 x 54	3600 AMPS	6300 AMPS	24

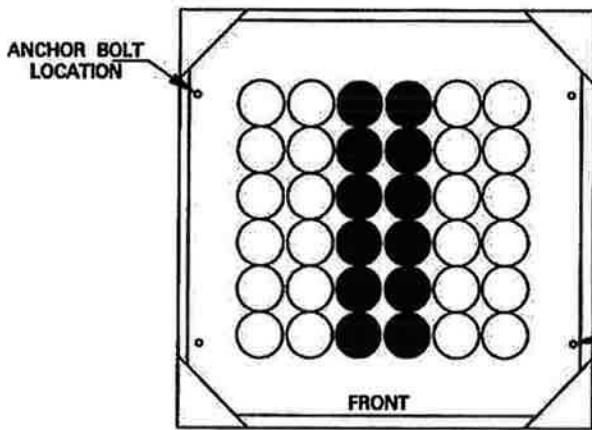

TOP VIEW

- COMPANY CONDUITS - ALWAYS IN THE MIDDLE
- CUSTOMER CONDUITS

ANCHOR BOLT
LOCATION
SEE DETAIL

NOTES:

1. WHEN INSTALLING NEAR A TRANSFORMER, MAKE SURE THERE IS AT LEAST 6 FT. OF CLEARANCE FROM THE FRONT AND REAR OF ENCLOSURE AND TRANSFORMER AND 3 FT. OF CLEARANCE ON EACH SIDE.
2. SEE SHEETS 47 AND 48 FOR PAD DETAILS.



**THREE PHASE
PAD MOUNTED
SECONDARY ENCLOSURE**

DDS-4 UG DETAIL SHEET 49 OF 57

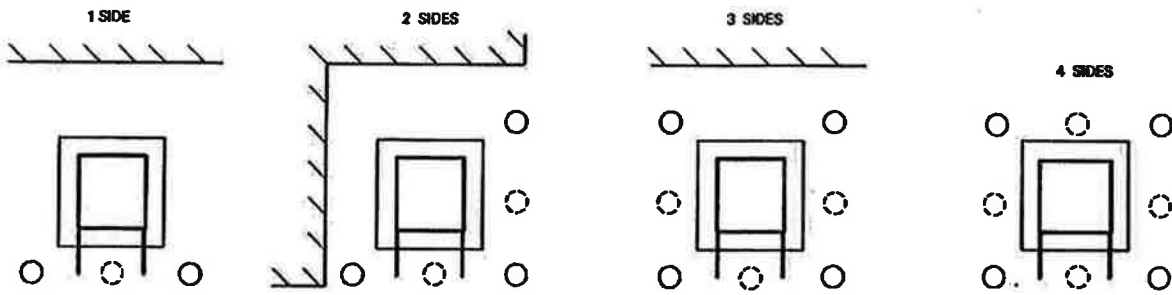

TYPICAL LAYOUT FOR TRAFFIC AND PARKING

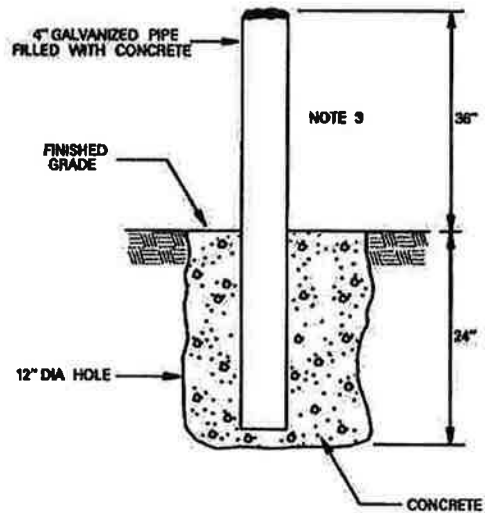
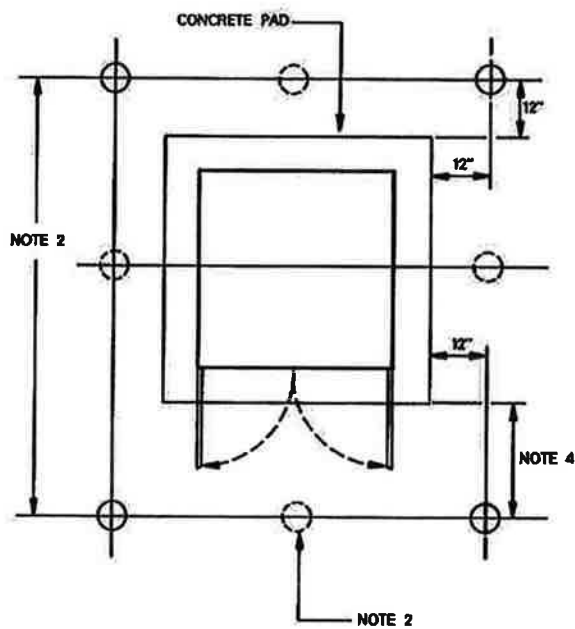

NOTES:

1. INSTALL GUARD POST WHERE PROTECTION FROM DAMAGE DUE TO VEHICULAR TRAFFIC IS NEEDED.
2. DISTANCE BETWEEN POSTS SHOULD NOT EXCEED 4 FEET. ADD ADDITIONAL POSTS WHERE NECESSARY TO MEET THIS CONDITION. VERIFY LOCATION OF POST IN FRONT OF TRANSFORMER TO ALLOW FOR DOOR OPENING.
3. INCREASE HEIGHT TO 48" AND DEPTH TO 36" IN TRUCK LOADING AREAS, AND INCREASE SIZE TO 6" GALVANIZED PIPE.
4. THIS DISTANCE TO BE LARGE ENOUGH TO ALLOW FULL OPENING OF ALL EQUIPMENT DOOR(S). CONTACT COMPANY REPRESENTATIVE TO VERIFY DIMENSION.



GUARD POST INSTALLATION

DDS-4 UG DETAIL SHEET 50 OF 57

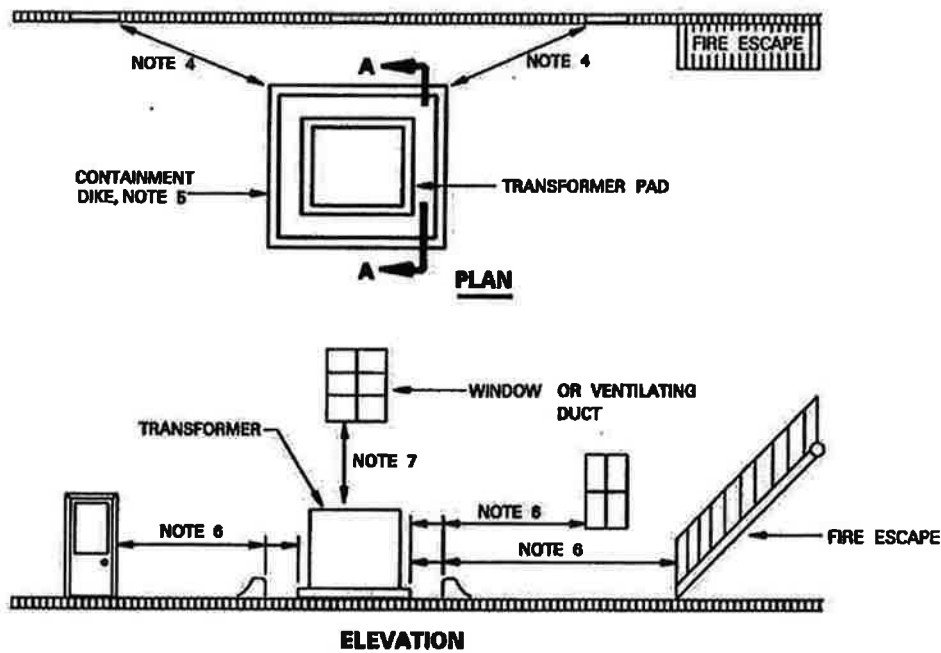

TRANSF. TYPE	BUILDING CONSTRUCTION		WINDOWS, DOORS & VENTS	FIRE ESCAPES
	FIRE RESISTIVE NOTE 3	NON-FIRE RESISTIVE		
1 PHASE	5'-0"	10'-0"	10'-0"	20'-0"
3 PHASE	5'-0"	15'-0"	15'-0"	20'-0"

CLEARANCE TABLE

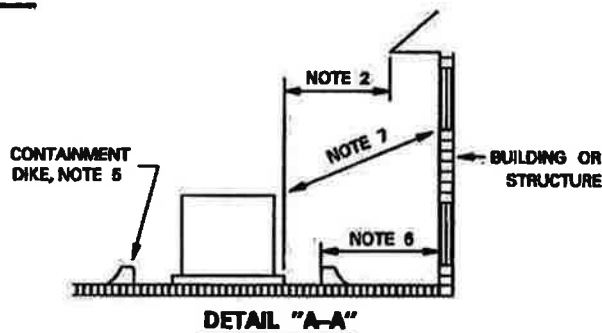

NOTES:

1. CLEARANCE FROM BUILDING WALLS SHALL COMPLY WITH THE CLEARANCE TABLE. ALL DIMENSIONS SHOWN ARE MINIMUM DIMENSIONS.
2. WHERE THERE ARE BUILDING EAVES OR OVERHANGS WITHIN 25'- 0" ABOVE GROUND, CLEARANCE SHALL BE MEASURED HORIZONTALLY BEGINNING FROM THE EDGE OF THE EAVE OR OVERHANG.
3. FIRE RESISTIVE BUILDING WALLS INCLUDE BRICK AND MASONRY STRUCTURES THAT HAVE A 2 HOUR FIRE RATING.
4. CLEARANCE TO BUILDING DOORS, WINDOWS, VENTS AND FIRE ESCAPES TO BE MEASURED RADIALLY.
5. LIQUID FLOW OF AREA SURROUNDING TRANSFORMER SHOULD BE AWAY FROM BUILDING. WHERE GROUND IS FLAT OR SLOPES TOWARD BUILDING, A DIKE SUFFICIENT TO CONTAIN ALL TRANSFORMER OIL FOR TRANSFORMERS 500 KVA AND LARGER SHALL BE PROVIDED.
6. CLEARANCES ARE MEASURED FROM PAD EDGE TO BUILDING WALL, OPENING, OVERHANG OR FIRE ESCAPE UNLESS A CONTAINMENT DIKE IS UTILIZED. IF A CONTAINMENT DIKE IS UTILIZED, CLEARANCE IS MEASURED FROM DIKE.
7. CLEARANCES FOR WINDOWS AND VENTS ABOVE TRANSFORMER ARE MEASURED RADIALLY FROM CLOSEST POINT ON TRANSFORMER.
8. PADMOUNTED TRANSFORMERS SHALL BE POSITIONED SUCH THAT HOTSTICK USE IS NOT REQUIRED ON THE SIDE FACING THE BUILDING. IF HOTSTICK USE IS REQUIRED ON THE BUILDING SIDE, CLEARANCES SHOWN IN DETAIL SHEET 52 SHALL BE MAINTAINED.
9. THERE SHOULD NOT BE ANY ABOVE GROUND OBSTRUCTIONS, SUCH AS SHRUBS, COOLING TOWERS, GAS METERS, FENCING, ETC. WITHIN 5'- 0' OF PAD OR OVERHANGS ABOVE PAD FACILITIES. REFERENCE DETAIL SHEET 52 FOR SCREENING CLEARANCES AROUND PADMOUNTED EQUIPMENT.
10. THERE SHOULD NOT BE ANY PIPING OR CONDUIT UNDER THE PAD (EXCEPTION: MUTUALLY AGREED UPON COMMUNICATION CONDUITS) OTHER THAN THOSE ENTERING THE TRANSFORMER.
11. TRANSFORMERS SHALL NOT OBSTRUCT FIRE LANE.
12. IT IS THE OWNER'S RESPONSIBILITY TO COMPLY WITH ANY INSURANCE REGULATIONS AFFECTING THE PREMISES.



**CLEARANCES OF
PADMOUNTED TRANSFORMERS
FROM BUILDINGS**

DDS-4 UG DETAIL SHEET 51 OF 57

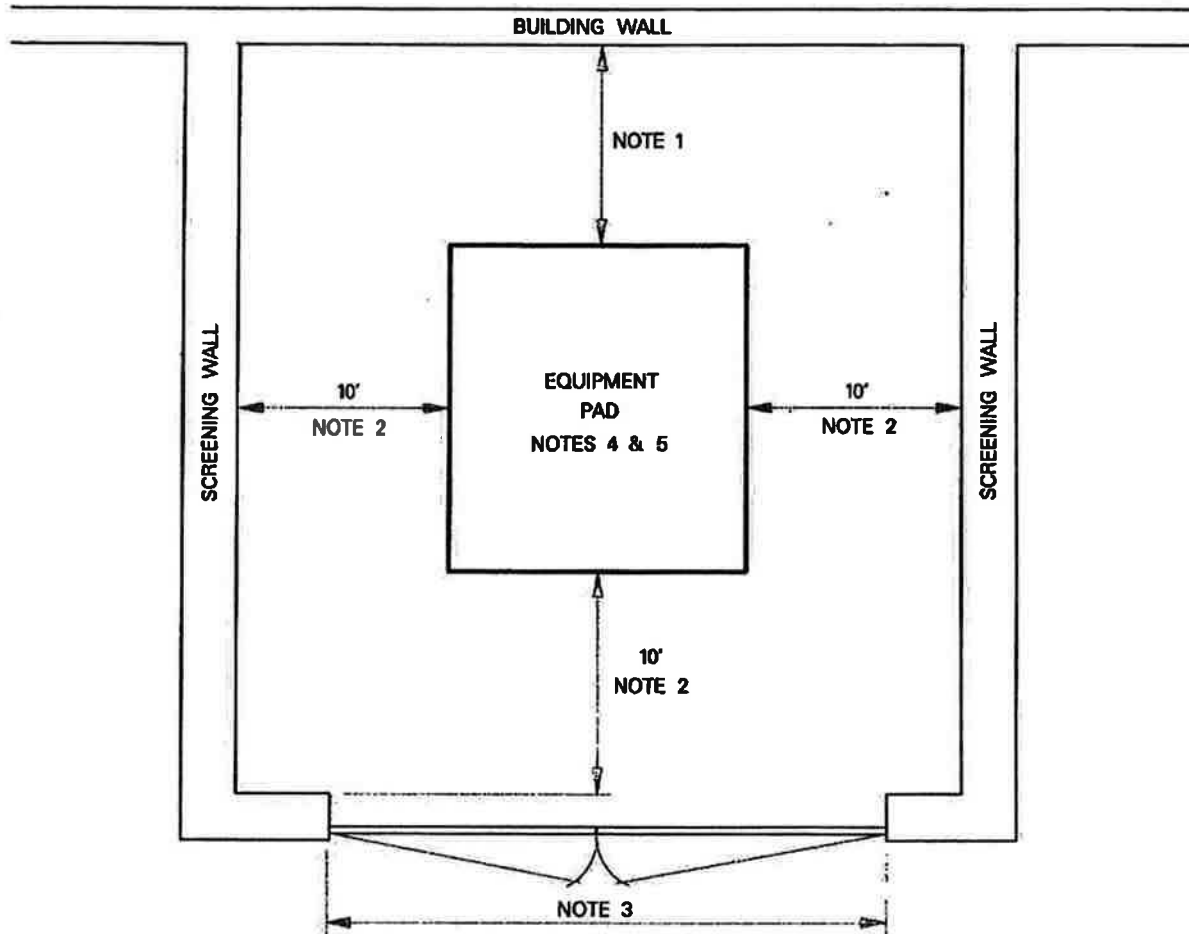

NOTES:

1. CLEARANCES TO BUILDING WALLS SHALL BE THE GREATER OF:
CLEARANCES LISTED IN DETAIL SHEET 51 FOR OIL FILLED EQUIPMENT,
10 FEET IF HOT STICK USE IS REQUIRED ON THIS SIDE OF EQUIPMENT, OR
5 FEET IF HOT STICK USE IS NOT REQUIRED ON THIS SIDE OF EQUIPMENT.
2. A MINIMUM OF 5 FEET CLEARANCE IS ALLOWED IF "HOT STICK" USE IS NOT REQUIRED
3. GATE SHALL OPEN OUTWARD AND THE WIDTH SHALL BE NO LESS THAN 10 FEET.
4. WHERE GROUND IS FLAT OR SLOPES TOWARD BUILDING, A DIKE SUFFICIENT TO CONTAIN ALL OIL FOR TRANSFORMERS 500 KVA AND LARGER SHALL BE PROVIDED. REFERENCE DETAIL SHEET 51.
5. WHEN TRANSFORMERS ARE INSTALLED, SCREENING WALLS SHALL PROVIDE ADEQUATE VENTILATION.



**CLEARANCES AROUND
PADMOUNTED EQUIPMENT**

DDS-4 UG DETAIL SHEET 52 OF 57

TRANSFORMER CLEARANCE DETAILS

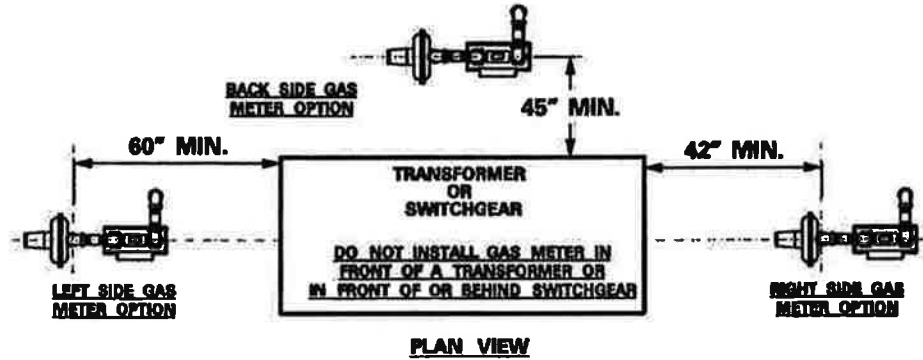
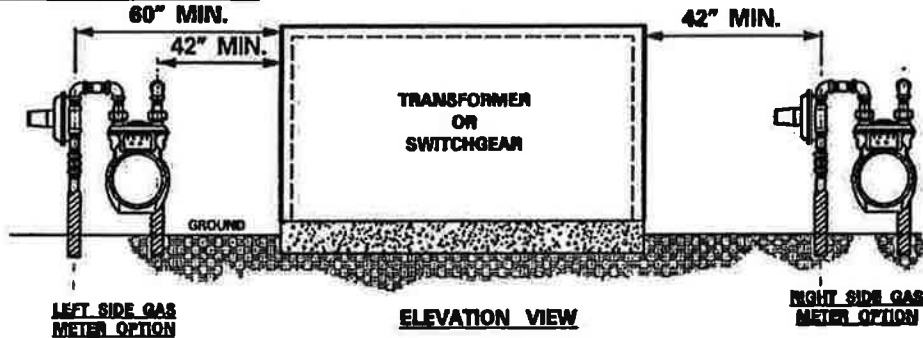

PEDESTAL CLEARANCE DETAILS

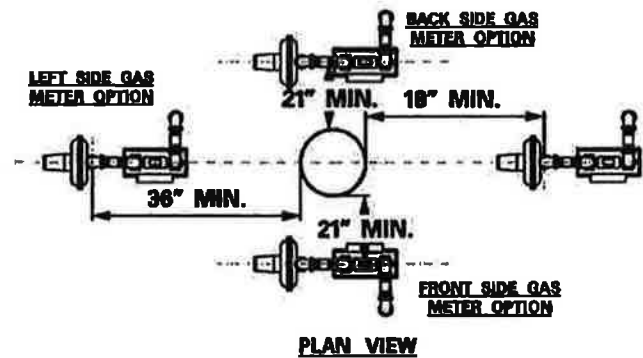
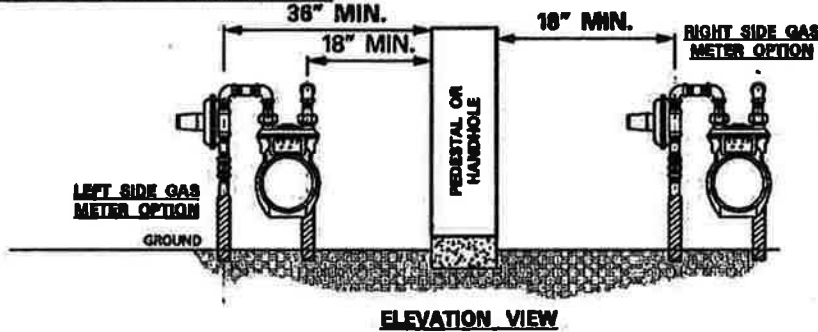

NOTES:

1. MEASUREMENTS ARE REFERENCED FROM THE INLET GAS RISER.
2. THE MEASUREMENTS WILL ENSURE:
 - A. THAT A MINIMUM CLEARANCE OF 36" IN. IS ATTAINED BETWEEN THE ENTIRE GAS METER INSTALLATION AND THE PADMOUNTED EQUIPMENT AND
 - B. THAT A MINIMUM CLEARANCE OF 12 IN. IS ATTAINED BETWEEN THE ENTIRE GAS METER INSTALLATION AND ALL OTHER ABOVEGROUND FACILITIES INCLUDING ELECTRIC AND OTHER UTILITY PEDESTALS AND HANDHOLES.
3. THIS STANDARD APPLIES TO 630 GAS METER INSTALLATIONS AND SMALLER. FOR LARGER METER INSTALLATIONS, CONTACT COMPANY REPRESENTATIVE FOR ASSISTANCE.
4. THIS DRAWING IS TYPICALLY USED WHEN THE GAS MAIN IS LOCATED IN AN ALLEY OR DEDICATED UTILITY EASEMENT.



ABOVEGROUND CLEARANCES FROM GAS METER INSTALLATIONS

DDS-4 UG DETAIL SHEET 53 OF 57

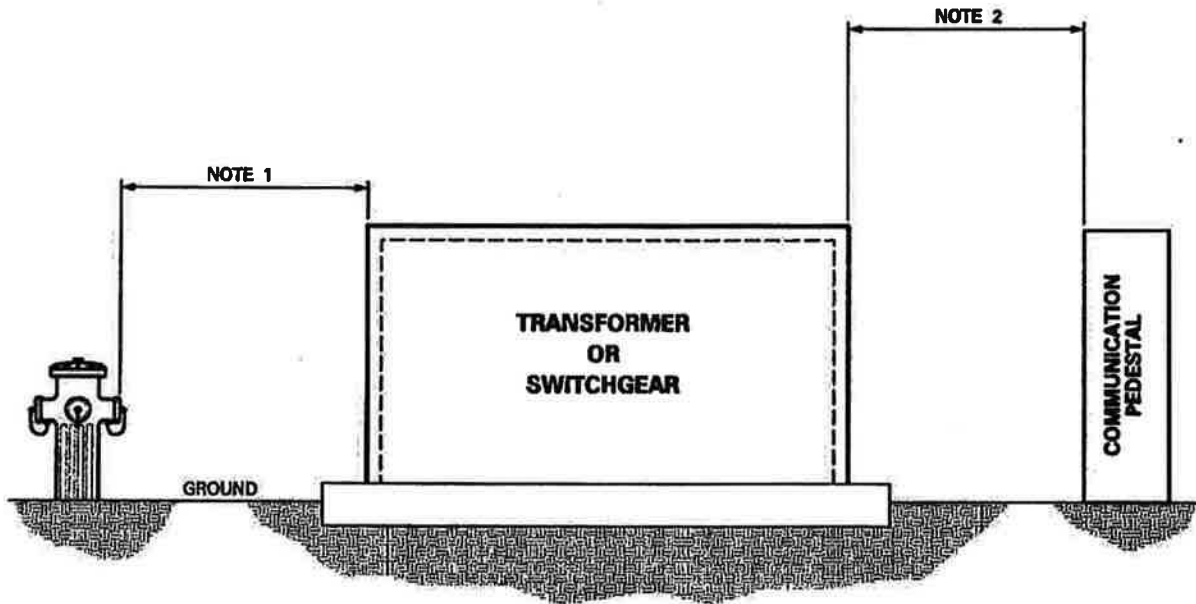

1. PADMOUNTED EQUIPMENT, PEDESTALS AND OTHER ABOVE GROUND ENCLOSURES SHOULD BE LOCATED NOT LESS THAN 4 FEET FROM FIRE HYDRANTS. WHERE CONDITIONS DO NOT PERMIT A CLEARANCE OF 4 FEET, A CLEARANCE OF NOT LESS THAN 3 FEET IS ALLOWED.
2. ALL ABOVE GROUND METALLIC POWER AND COMMUNICATION EQUIPMENT (PEDESTALS, TRANSFORMER CASES, APPARATUS CASES, ETC.) THAT ARE SEPARATED BY A DISTANCE OF 6 FEET OR LESS SHALL BE BONDED. REFERENCE DETAIL SHEET 18 FOR METHOD FOR PROVIDING FOREIGN UTILITY COMPANY EQUIPMENT GROUND.



**CLEARANCES OF ABOVEGROUND
EQUIPMENT - FOREIGN UTILITIES
ENCLOSURES AND EQUIPMENT**

DDS-4 UG DETAIL SHEET 54 OF 57

SOURCE CONDUITS, AS REQUIRED,
TYPICALLY IN THE MIDDLE

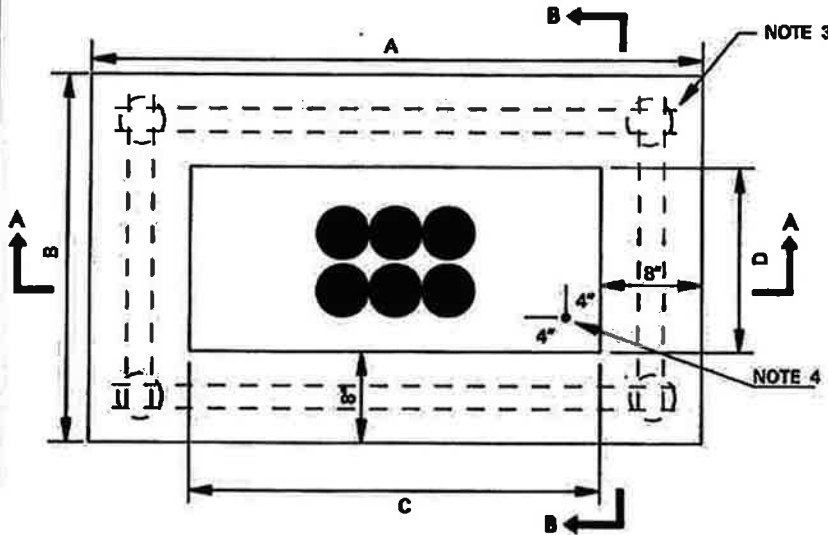

ENCLOSURE SIZE	DIMENSIONS			
	A	B	C	D
44" x 24"	54"	32"	38"	16"

REINFORCING SCHEDULE		
NUMBER OF #3 BARS	LENGTH	WEIGHT (LBS)
4	50"	6.3
4	28"	3.6

0.15 CU YARDS CONCRETE- PAD
0.085 CU. YARDS CONCRETE- PIERS
TOTAL WEIGHT OF PAD- 583 LBS
TOTAL WEIGHT OF PIERS- 262 LBS

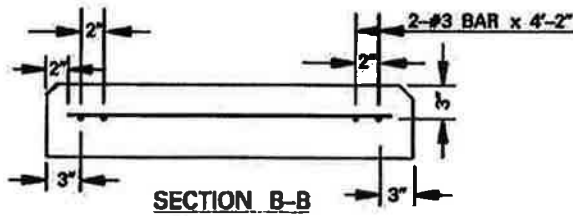
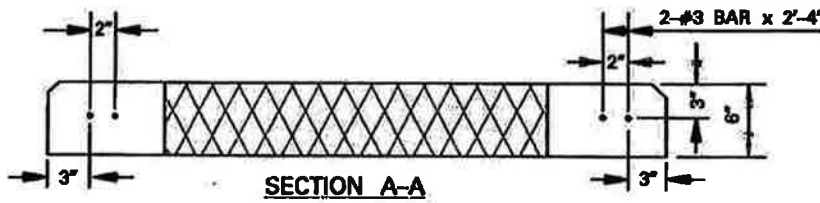

NOTES:

- SEE SHEET 56 FOR ENCLOSURE DETAILS.
- CONDUIT CONFIGURATION WILL DEPEND ON QUANTITY AND SIZE OF CONDUITS.
- PIERS SHOULD BE INSTALLED ON ALL PADS TO A DEPTH OF 5 FEET UNLESS ROCK OR OTHER HARD SURFACES ARE ENCOUNTERED. IF ROCK OR OTHER HARD SURFACES ARE ENCOUNTERED PRIOR TO A 5 FOOT DEPTH, PIERS SHOULD EXTEND 6 INCHES INTO HARD SURFACE. REFERENCE SHEET 17 FOR PIER DETAIL.
- RECOMMENDED LOCATION FOR 5/8" X 8' COPPER GROUND ROD AS SHOWN.
- SERVICE ENCLOSURES, WHEN REQUIRED, ARE TO BE PROVIDED BY COMPANY AND INSTALLED BY CONTRACTOR.
- THE CONTRACTOR IS TO PROVIDE, INSTALL AND MAINTAIN (1) THE PAD, ASSOCIATED RACEWAYS AND CABLE FROM THE SERVICE ENCLOSURE TO THE PADMOUNTED TRANSFORMER AND (2) THE CABLE AND ASSOCIATED RACEWAYS FROM THE SERVICE ENCLOSURE TO THE METERS.



**PAD DETAILS FOR
44" X 52" X 24"
SERVICE ENCLOSURE**

DDS-4 UG DETAIL SHEET 55 OF 57

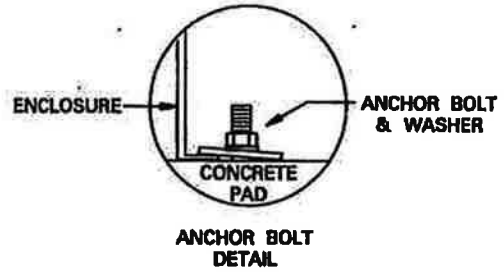
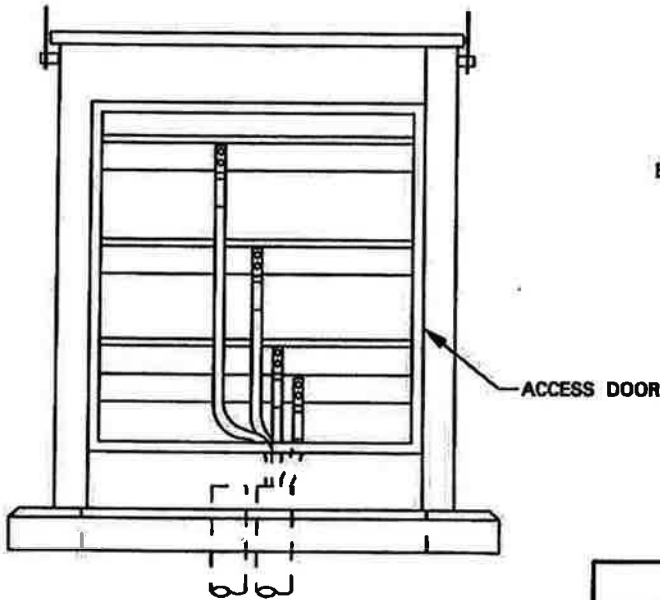

SPECIFICATIONS		
CENTER TAP RATING	SETS OF SET SCREWS	SETS OF HOLES
2500 AMPS	30	18

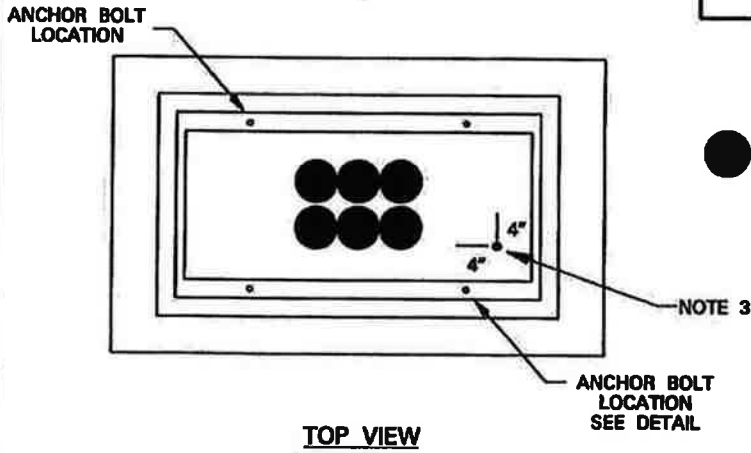

● SOURCE CONDUITS - ALWAYS IN THE MIDDLE

NOTES:

1. SEE SHEET 56 FOR PAD DETAILS.
2. CONDUIT CONFIGURATION WILL DEPEND ON QUANTITY AND SIZE OF CONDUITS.
3. RECOMMENDED LOCATION FOR 5/8" X 8' COPPER GROUND ROD AS SHOWN.
4. SERVICE ENCLOSURES, WHEN REQUIRED, ARE TO BE PROVIDED BY COMPANY AND INSTALLED BY CONTRACTOR.
5. THE CONTRACTOR IS TO PROVIDE, INSTALL AND MAINTAIN (1) THE PAD, ASSOCIATED RACEWAYS AND CABLE FROM THE SERVICE ENCLOSURE TO THE PADMOUNTED TRANSFORMER AND (2) THE CABLE AND ASSOCIATED RACEWAYS FROM THE SERVICE ENCLOSURE TO THE METERS.



**PAD MOUNTED
SERVICE ENCLOSURE
44" X 52" X 24"**

DDS-4 UG DETAIL SHEET 56 OF 57

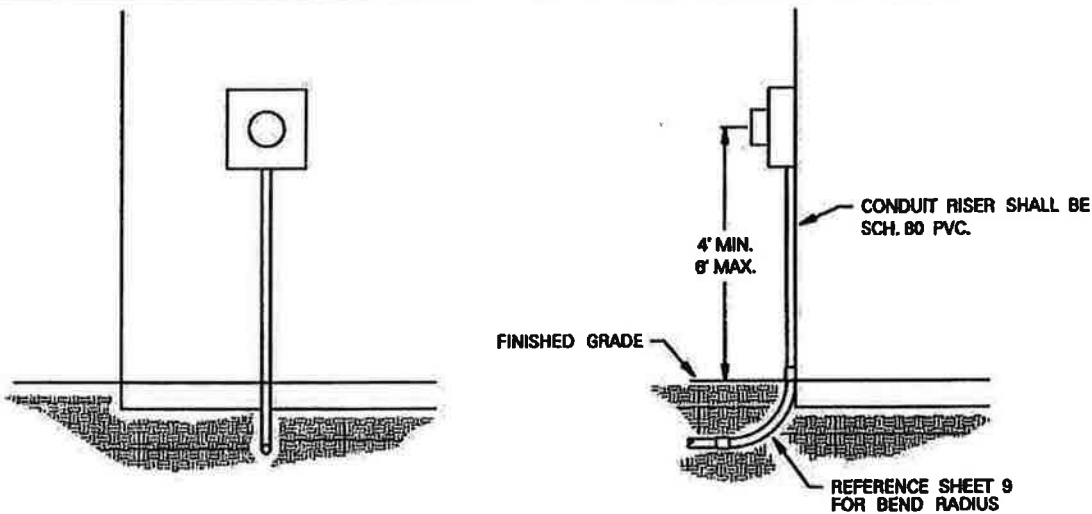

TYPICAL SINGLE METER INSTALLATION

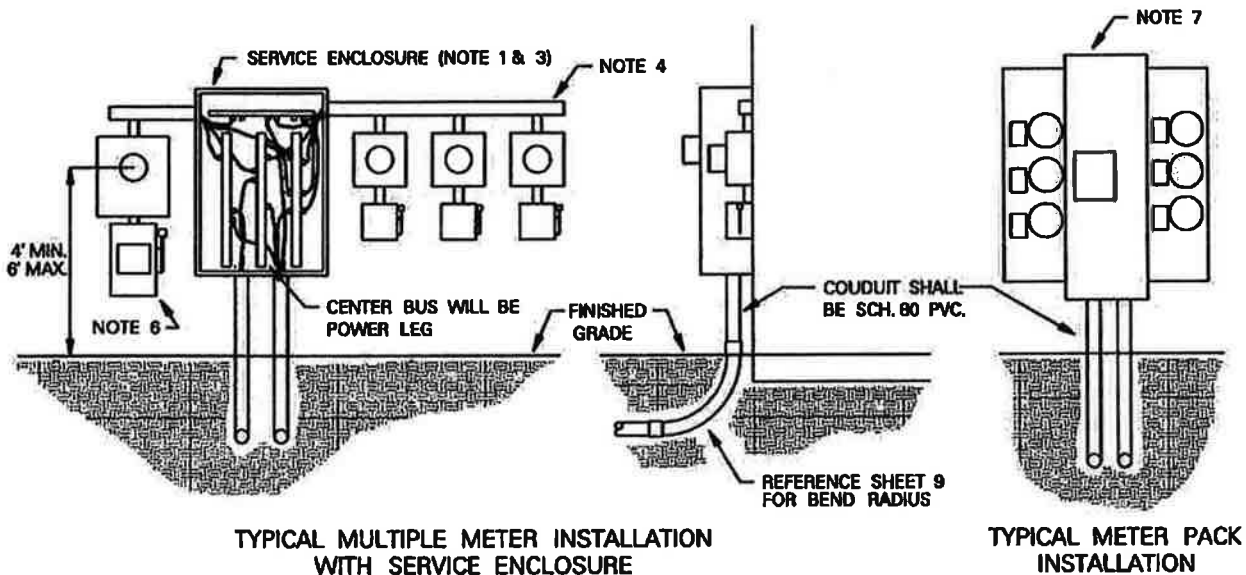

TYPICAL MULTIPLE METER INSTALLATION WITH SERVICE ENCLOSURE

TYPICAL METER PACK INSTALLATION

NOTES:

1. SERVICE ENTRANCE ENCLOSURE (FOR MULTIPLE METER INSTALLATIONS) PROVIDED BY COMPANY AND INSTALLED BY CONTRACTOR FOR SERVICE ENTRANCES THROUGH 2500 AMPS. CONTACT COMPANY REPRESENTATIVE FOR INFORMATION.
2. METER SOCKETS INSTALLED BY CONTRACTOR.
3. REFERENCE ONCOR'S "ELECTRIC SERVICE GUIDELINES" FOR METER AND SERVICE ENCLOSURE INFORMATION.
4. CONDUCTORS, RACEWAY AND GUTTER PROVIDED AND INSTALLED BY CONTRACTOR.
5. SERVICE ENTRANCE CONDUCTORS TO BE CONTINUOUS FROM METER SOCKET INTO SERVICE ENCLOSURE.
6. METER DISCONNECT SWITCH AS ALLOWED BY LOCAL INSPECTION AUTHORITY. VERIFY ACCEPTANCE PRIOR TO INSTALLATION.
7. CONTACT COMPANY FOR APPROVAL OF METER PACKS PRIOR TO LETTING BIDS AND INSTALLING EQUIPMENT.
8. EACH SOCKET MUST BE CLEARLY AND PERMANENTLY MARKED ON THE INTERIOR AND EXTERIOR OF THE METER SOCKET TO INDICATE EACH APARTMENT OR LOCATION SERVED.



TYPICAL METER INSTALLATIONS

DDS-4 UG DETAIL SHEET 57 OF 57

SPECIAL PROVISION

361---001

Full-Depth Repair of Concrete Pavement

For this project, Item 361, "Full-Depth Repair of Concrete Pavement," of the Standard Specifications, is hereby amended with respect to the clauses cited below, and no other clauses or requirements of this Item are waived or changed hereby.

Article 361.2. Materials is supplemented by the following:

- Item 438, "Cleaning and Sealing Joints and Cracks (Rigid Pavement and Bridge Decks)"
- DMS 6310, "Joint Sealants and Fillers"

Article 361.3. Construction. The second paragraph is voided and replaced by the following:

Remove or repair loose or damaged base material, and replace or repair it with approved base material to the original top of base grade. Place at least 1 in. of asphalt concrete or a polyethylene sheet at least 4 mils thick as a bond breaker at the interface of the base and the new pavement. Allow concrete used as a base material to attain sufficient strength to prevent displacement when placing pavement concrete.

Article 361.3. Construction. The fifth paragraph is voided and replaced by the following:

Cure repaired area for at least 72 hr. or until overlaid with asphalt concrete, if required, or until the area is opened to traffic. For repair areas to be opened to traffic before 72 hr.:

- Use curing mats to maintain a minimum concrete surface temperature of 70°F when the air temperature is less than 70°F.
- The Engineer may waive the requirements of Section 360.4.G.4, "Temperature Restrictions," but the repair areas must then be cured using wet curing mats.

Saw and seal contraction joints in the repair area in accordance with Item 360, "Concrete Pavement." Remove repair area debris from the right of way each day.

SPECIAL SPECIFICATION

3001

Ultra-Thin Bonded Hot Mix Wearing Course (UTBHMWC)

1. **Description.** Construct a surface course composed of a warm spray-applied polymer modified emulsion membrane followed immediately with a hot plant mixed gap-graded paving mixture. Provide a wearing course with a minimum of 1/2 in. for Type A, 5/8 in. for Type B and 3/4 in. for Type C.
2. **Materials.** Furnish materials of uniform quality throughout that meet the requirements of the plans and specifications. Notify the Engineer of all materials sources. Notify the Engineer before changing any material source or formulation. When making a source or formulation change, the Engineer will verify that the specification requirements are met and may require a new laboratory mixture design, trial batch, or both. The Engineer may sample and test project materials at any time throughout the duration of the project to verify specification compliance.
 - A. **Aggregate.** Furnish aggregates from sources that conform to the requirements shown in Table 1, and as specified in this Section, unless otherwise shown on the plans. Provide aggregate stockpiles that meet the definition in this Section. Do not use recycled asphalt pavement (RAP) or reclaimed asphalt shingles in ultra-thin bonded hot mix wearing course (UTBHMWC) mixtures. Supply mechanically crushed gravel or stone aggregates that meet the definitions in Tex-100-E. The Engineer will designate the plant or the quarry as the sampling location. Samples must be from materials produced for the project. The Engineer will establish the surface aggregate classification (SAC) and perform Los Angeles Abrasion, Magnesium Sulfate Soundness, and Micro-Deval tests. Perform all other aggregate quality tests listed in Table 1 and perform Tex-107-E on mineral fillers if used. Document all test results on the mixture design report. The Engineer may perform tests on independent or split samples to verify Contractor test results. Stockpile aggregates for each source and type separately. Determine aggregate gradations for mixture design and production testing based on Tex-200-F, Part II "Washed Sieve Analysis." Do not add material to an approved stockpile from sources that do not meet the aggregate quality requirements of the Department's Bituminous Rated Source Quality Catalog (BRSQC) unless otherwise approved.
 1. **Coarse Aggregate.** Coarse aggregate stock piles must have no more than 20% material passing the No. 8 sieve. Provide aggregates from sources listed in the BRSQC. Provide non-listed sources only when tested by the Engineer and approved before use. Allow 30 calendar days for the Engineer to sample, test, and report results for non-listed sources.

Provide coarse aggregate with a minimum SAC as shown on the plans. SAC requirements only apply to aggregates used on the surface of travel lanes, unless

otherwise shown on the plans. The SAC for sources on the Department's Aggregate Quality Monitoring Program (AQMP) are listed in the BRSQC.

Unless otherwise shown on the plans, Class B aggregate, meeting all other requirements in Table 1, may be blended with a Class A aggregate in order to meet requirements for Class A materials. When blending Class A and B aggregates to meet a Class A requirement, ensure at least 50% by weight of the material retained on the No. 4 sieve comes from the Class A aggregate source. Blend by volume if the bulk specific gravities of the Class A and B aggregates differ by more than 0.300. When blending, do not use Class C or D aggregates.

2. **Fine Aggregate.** Fine aggregate is defined as that part of the aggregate passing the No. 4 sieve. The following tests in Table 1. will apply to the fine aggregate blend with the exception of the Methylene Blue Value test, which applies to each source of fine aggregate in the final blend.
3. **Mineral Filler.** Mineral filler may be used to meet the combined gradation requirements. Hydrated lime, and Type 1 Portland cement are acceptable as mineral filler. Use mineral filler where 100% passes the No. 30 sieve, and 75% to 100% passes the No. 200 sieve.

Proportion the mineral filler into the mix using a vane meter or an equivalent metering device acceptable to the Engineer. Maintain a constant supply of mineral filler to the measuring device using a hopper or other acceptable storage system.

4. **RAP.** Do not use RAP in UTBHMWC mixtures.

Table 1
Aggregate Quality Requirements

Property	Test Method	Requirement
Coarse Aggregate Properties		
SAC	AQMP	As shown on plans
Deleterious Material, % , Max	Tex-217-F, Part I	1.0
Decantation, % , Max	Tex-217-F, Part II	1.5
Micro-Deval Abrasion, % , Max	Tex-461-A	Note 1
Los Angeles Abrasion, % , Max	Tex-410-A	35
Magnesium Sulfate Soundness, 5 Cycle, % , Max	Tex-411-A	20
Coarse Aggregate Angularity, 2 Crushed Faces, % , Min	Tex 460-A, Part I	95 ²
Flat and Elongated Particles @ 5:1, % , Max	Tex 280-F	10
Fine Aggregate Properties		
Sand Equivalent, Min	Tex 203F	45
Methylene Blue, Max	AASHTO TP57-99	10
Fine Aggregate Angularity, Min	AASHTO T304-96	40

1. Not used for acceptance purpose. Used by the engineer as an indicator of the need for further investigation

2. Only applies to crushed gravel.

- B. **Baghouse Fines.** Fines collected by the baghouse or other dust collecting equipment may be re-introduced into the mixing drum provided the final combined gradation meets the requirements in Table 4.

C. **Asphalt Binder.** Furnish performance grade (PG) asphalt binder for the paving mixture that meets requirements of Item 300, "Asphalts, Oils, and Emulsions."

1. **PG Binder.** When PG binder is specified, provide an asphalt binder with a temperature grade as shown on the plans in accordance with Section 300.2.J, "Performance Graded Binders."
2. **Membrane.** Provide a smooth and homogeneous polymer modified emulsion meeting the requirements of Table 2.

Table 2.

Polymer Modified Emulsion Requirements

Test on Emulsion	Test Method	Min	Max
Viscosity @ 77°F, SSF	Tex-513-C	20	100
Storage Stability ¹ , %	Tex-521-C		1
Demulsibility (for anionic emulsions), 35 ml of 0.02 N CaCl ₂ , %	Tex-521-C	60	
Demulsibility (for cationic emulsions), 35 ml 0.8% sodium dioctyl sulfosuccinate, %	Tex-521-C	60	
Sieve Test ² , %	Tex-521-C		0.05
Residue from Distillation @400°F, % Oil Portion from Distillation ml of Oil per 100 g Emulsion ³	Tex-521-C	63	

Test on Residue from Distillation	Test Method	Min	Max
Elastic Recovery @ 50°F, 50 mm/min, %	Tex-539-C	60	
Penetration @ 77°F, 100 g, 5 sec, 0.1 mm	Tex-502-C	100	150

1. After standing undisturbed for 24 hours, the surface must be smooth, must not exhibit a white or milky colored substance, and must be a homogeneous color throughout.

2. May be required by the Engineer only when the emulsion cannot be easily applied in the field.

3. The temperature on the lower thermometer shall be brought slowly to 350°F ± 10°F and maintained at this temperature for 20 minutes. The total distillation shall be completed in 60 ± 5 minutes from the first application of heat.

D. **Additives.** When shown on the plans, use the type and rate of additive specified. Other additives that facilitate mixing or improve the quality of the mixture may be allowed when approved.

1. **Hydrated Lime.** Add lime as mineral filler at a rate of 1.0% by weight of the total dry aggregate. Do not add lime directly into the mixing drum of any plant where lime is removed through the exhaust stream unless the plant has a baghouse or dust collection system that re-introduces the lime back into the drum.
2. **Antistripping Agents.** If lime or a commercial antistripping (liquid antistrip) agent is specified or selected for use, add in accordance with Item 301, "Asphalt Antistripping Agents." When the plans require lime to be added as an antistripping agent, lime added as mineral filler will count towards the total quantity of lime specified.
3. **Equipment.** Provide equipment to produce, haul, and place hot mixed asphalt materials. Ensure weighing and measuring equipment complies with Item 320, "Equipment for Asphalt Concrete Pavement." Synchronize equipment to produce a mixture meeting the required proportions.

A. **Production Equipment.** Provide:

- drum-mix type, weigh-batch, or modified weigh-batch mixing plants that ensure a uniform, continuous production;

- automatic proportioning and measuring devices with interlock cut-off circuits, which stop operations if the control system malfunctions;
 - visible readouts indicating the weight or volume of asphalt and aggregate proportions;
 - safe and accurate means to take required samples by inspection forces;
 - permanent means to check the output of metering devices and to perform calibration and weight checks; and
 - additive-feed system to ensure a uniform, continuous material flow in the desired proportion.
1. **Drum-Mix Plants.** Provide a mixing plant that complies with the requirements below.
- a. **Aggregate Feed System.** Provide:
- a minimum of 1 cold aggregate bin for each stockpile of individual materials used to produce the mix;
 - bins designed to prevent overflow of material from one bin to another;
 - scalping screens or other approved methods to remove all oversized material, roots, or other objectionable materials;
 - a feed system to ensure a uniform, continuous material flow in the desired proportion to the dryer;
 - an integrated means for moisture compensation;
 - belt scales, weigh box, or other approved devices to measure the weight of the combined aggregate; and
 - cold aggregate bin flow indicators that automatically signal interrupted material flow.
- b. **Mineral Filler Feed System.** If lime mineral filler is required, provide a closed system for mineral filler that maintains a constant supply with minimal loss of material through the exhaust system. Tie the measuring device into the automatic plant controls to automatically adjust the supply of mineral filler to plant production and provide a consistent percentage to the mixture.
- c. **Heating, Drying, and Mixing Systems.** Provide:
- a dryer or mixing system to thoroughly dry the aggregate during heating;
 - a heating system that controls the temperature during production to prevent aggregate and asphalt binder damage;
 - a heating system that completely burns fuel and leaves no residue;
 - a recording thermometer that continuously measures and records the mixture discharge temperature.
- d. **Asphalt Binder Equipment.** Supply equipment to heat binder to the required temperature. Equip heating apparatus with a continuously recording thermometer located at the highest temperature point. Produce a 24-hour chart

of the recorded temperature. Place a device with automatic temperature compensation, which accurately meters the binder in the line leading to the mixer.

Furnish a sampling port on the line between the storage tank and mixer. Supply an additional sampling port between any additive blending device and mixer. Locate the sampling port downstream of any additive addition so the sample will be a representation of the final asphalt-additive blend going to the roadway.

- e. **Mixture Storage and Discharge.** Provide a surge-storage system to minimize interruptions during operations, unless otherwise approved. Furnish a gob hopper, batcher or other device to minimize segregation in the bin. Furnish a device that is timed or cycled such that it does not completely empty during the cycling operation. Provide an automated system that weighs the mixture upon discharge and produces a ticket showing:
 - date,
 - project identification number,
 - plant identification,
 - mix identification,
 - vehicle identification,
 - total weight of the load,
 - tare weight of the vehicle,
 - weight of mixture in each load, and
 - load number or sequential ticket number for the day.
 - f. **Truck Scales.** Provide standard platform scales at an approved location.
2. **Weigh-Batch Plants.** Provide mixing plant that complies with Section 3.A.1, "Drum-Mix Plants," except as required below.
- a. **Screening and Proportioning.** Provide enough hot bins to separate the aggregate and to control proportioning of the mixture type specified. Supply bins that discard excessive and oversized material through overflow chutes. Provide safe access for inspectors to obtain samples from the hot bins.
 - b. **Aggregate Weigh Box and Batching Scales.** Provide a weigh box and batching scales to hold and weigh a complete batch of aggregate. Provide an automatic proportioning system with low bin indicators, which automatically stop production when material level in any bin is not sufficient to complete the batch.
 - c. **Asphalt Binder Measuring System.** Provide bucket and scales of sufficient capacity to hold and weigh binder for 1 batch.
 - d. **Mixer.** Equip mixers with an adjustable automatic timer that controls the dry and wet mixing period and locks the discharge doors for the required mixing

period. Furnish a pug mill with a mixing chamber large enough to prevent spillage.

3. **Modified Weigh-Batch Plants.** Provide mixing plant that complies with Section 3.A.2, "Weigh-Batch Plants," except as specifically described below.

a. **Aggregate Feeds.** Aggregate control is required at the cold feeds. Hot bin screens are not required.

b. **Surge Bins.** Provide 1 or more bins large enough to produce 1 complete batch of mixture.

B. **Hauling Equipment.** Provide trucks with enclosed sides to prevent asphalt mixture loss. Cover each load of mixture with waterproof tarpaulins. Before use, clean all truck beds to ensure the mixture is not contaminated. When necessary, coat the inside truck beds with an approved release agent from the list maintained by the Construction Division.

C. **Placement and Compaction Equipment.** Provide equipment that does not damage underlying pavement. Comply with laws and regulations concerning overweight vehicles.

1. **Paver.** Furnish a paver that will spray the membrane, apply the mixture, and level the surface of the mat in a single pass. Configure the paver so that the mixture is placed no more than 5 seconds after the membrane is applied. Ensure the paver does not support the weight of any portion of hauling equipment other than the connection. Provide loading equipment that does not transmit vibrations or other motions to the paver that adversely affects the finished pavement quality. Equip the paver with an automatic dual longitudinal-grade control system.

a. **Tractor Unit.** Supply a tractor unit that can push or propel vehicles, dumping directly into the finishing machine to obtain the desired lines and grades to eliminate any hand finishing.

b. **Membrane Storage Tank and Distribution System.** Equip the paver with an insulated storage tank having a minimum capacity of 900 gallons. Provide a metered mechanical pressure sprayer on the paver to apply a uniform membrane at the specified rate. Locate the spray bar on the paver so that the membrane is applied immediately in front of the screed unit. Provide a read out device on the paver to monitor the membrane application rate.

c. **Variable Width Screed.** Provide a heated compacting (vibratory) screed that will produce a finished surface, which meets longitudinal and transverse profile, typical section, and placement requirements. Screed extensions must provide the same compacting action and heating as the main unit, unless otherwise approved.

d. **Grade Reference.** Ensure that the longitudinal controls can operate from any longitudinal grade reference, including a ski, mobile string line, or matching shoes. Furnish paver skis or mobile string line at least 40 ft. long unless otherwise approved.

2. **Material Transfer Devices.** Provide the specified type of device when shown on the plans. Ensure devices provide a continuous, uniform mixture flow to the asphalt paver. Ensure that no material is deposited on the roadway in front of the paver. Do not use windrow pick-up devices.
 3. **Handheld Infrared Thermometer.** Provide a handheld infrared thermometer meeting the requirements of Tex-244-F.
 4. **Rollers.** Provide steel-wheel rollers meeting the requirements of Item 210, "Rolling" except provide rollers weighing a minimum of 10 tons for each roller required. Operate rollers in static (non-vibrating) mode only.
 5. **Straightedges and Templates.** Furnish 10-ft. straightedges and other templates as required or approved.
- D. Field Laboratory.** Unless otherwise shown on the plans, provide and maintain a Type D Structure (Asphalt Mix Control Laboratory) in accordance with Item 504, "Field Office and Laboratory" and details shown on the plans.
4. **Construction.** Produce, haul, place, and compact the specified paving mixture. When shown on the plans, notify the Engineer to schedule and participate in a prepping meeting as required in the Quality Control Plan (QCP).
 - A. **Certification.** Personnel certified by the Department-approved program must conduct all mixture designs, sampling, and testing in accordance with Table 3. In addition to meeting the certification requirements in Table 3, all Level II certified specialists must successfully complete an approved Superpave (SP) training course. Supply the Engineer with a list of certified personnel and copies of their current certificates before beginning production and when personnel changes are made. Provide a mixture design that is developed and signed by a Level II certified specialist. Provide a Level IA certified specialist at the plant during production operations. Provide a Level IB certified specialist to conduct placement tests.

Table 3
Test Methods, Test Responsibility, and Minimum Certification Levels

1. Aggregate Testing	Test Method	Contractor	Engineer	Level
Sampling	Tex-400-A	✓	✓	IA
Dry Sieve	Tex-200-F, Part I	✓	✓	IA
Washed Sieve	Tex-200-F, Part II	✓	✓	IA
Deleterious Material	Tex-217-F, Part I	✓	✓	II
Decantation	Tex-217-F, Part II	✓	✓	II
Los Angeles Abrasion	Tex-410-A		✓	
Magnesium Sulfate Soundness	Tex-411-A		✓	
Micro-Deval	Tex-461-A		✓	
Coarse Aggregate Angularity	Tex-460-A	✓	✓	II
Sand Equivalency	Tex-203-F	✓	✓	II
Methylene Blue	AASHTO TP57-99	✓	✓	II
Flat and Elongated Particles	Tex 280-F	✓	✓	II
2. Mix Design & Verification	Test Method	Contractor	Engineer	Level
Design and JMF Changes	Tex-204-F	✓	✓	II
Mixing	Tex-205-F	✓	✓	II
Molding (SGC)	Tex-241-F	✓	✓	II
Laboratory-molded Density	Tex-207-F	✓	✓	II
Rice Gravity	Tex-227-F	✓	✓	IA
Ignition Oven Calibration ¹	Tex-236-F	✓	✓	II
Drain-down	Tex-235-F	✓	✓	IA
Boil Test	Tex-530-C	✓	✓	IA
Cantabro Loss	Tex-245-F	✓	✓	II
3. Production Testing	Test Method	Contractor	Engineer	Level
Control Charts	Tex-233-F	✓	✓	IA
Mixture Sampling	Tex-222-F	✓	✓	
Gradation & Asphalt Content ¹	Tex-236-F	✓	✓	IA
Moisture Content	Tex-212-F	✓	✓	IA
Micro-Deval	Tex-461-A		✓	
Drain-down	Tex-235-F	✓	✓	IA
Boil Test	Tex-530-C	✓	✓	IA
Aging Ratio	Tex-211-F		✓	
4. Placement Testing	Test Method	Contractor	Engineer	Level
Control Charts	Tex-222	✓	✓	IA
Ride Quality Measurement	Tex-1001-S	✓	✓	IB
Thermal profile	Tex-244-F	✓	✓	IB
Tack Coat Adhesion	Tex-243-F		✓	
Permeability	Tex-246-F	✓	✓	IB

1. Refer to Section 4.E for exceptions to using ignition oven.

B. Reporting. Use Department-provided software to record and calculate all test data. The Engineer and the Contractor will provide any available test results to the other party when requested. The Engineer and the Contractor will immediately report to the other party any test result that requires production to be suspended or fails to meet the specification requirements. Use the approved communication method (e.g., email, diskette, hard copy) to submit test results to the Engineer.

When directed, use the procedures described in Tex-233-F to plot the results of all productions and placement testing. Update the control charts as soon as test results for each subplot become available. Make the control charts readily accessible at the field laboratory. The Engineer may suspend production for failure to update control charts.

- C. **Quality Control Plan (QCP).** Develop and follow the QCP in detail. Obtain approval from the Engineer for changes to the QCP made during the project. The Engineer may suspend operations if the Contractor fails to comply with the QCP.

When directed, submit a written QCP to the Engineer before the mandatory prepping meeting. Receive the Engineer's approval of the QCP before beginning production. Include the following items in the QCP.

1. **Project Personnel.** For project personnel, include:
 - a list of individuals responsible for QC with authority to take corrective action and
 - contact information for each individual listed.
2. **Material Delivery and Storage.** For material delivery and storage, include:
 - the sequence of material processing, delivery, and minimum quantities to assure continuous plant operations;
 - aggregate stockpiling procedures to avoid contamination and segregation;
 - frequency, type, and timing of aggregate stockpile testing to assure conformance of material requirements before mixture production; and
 - procedure for monitoring the quality and variability of asphalt binder and the polymer modified emulsion membrane.
3. **Production.** For production, include:
 - loader operation procedures to avoid contamination in cold bins,
 - procedures for calibrating and controlling cold feeds,
 - procedures to eliminate debris or oversized material,
 - procedures for adding and verifying rates of each applicable mixture component (e.g., aggregate, asphalt binder, lime, liquid antistriper),
 - procedures for reporting job control test results, and
 - procedures to avoid segregation and drain-down in the silo.
4. **Loading and Transporting.** For loading and transporting, include:
 - type and application method for release agents and
 - truck loading procedures to avoid segregation.
5. **Placement and Compaction.** For placement and compaction, include:
 - proposed agenda for mandatory prepping meeting including date and location;
 - type and application method for release agents in the paver and on rollers, shovels, lutes, and other utensils
 - procedures for the transfer of mixture into the paver while avoiding segregation and preventing material spillage;
 - process to balance production, delivery, paving, and compaction to achieve continuous placement operations;

- paver operations (e.g., operation of wings, height of mixture in auger chamber) to avoid physical and thermal segregation and other surface irregularities; and
- procedures to construct quality longitudinal and transverse joints.

D. Mixture Design. Unless otherwise shown on the plans, use Tex-247-F, to design a mixture meeting the requirements listed in Tables 1, 4 and 5.

At any time during the project, the Contractor may submit a new mixture design. The Engineer will approve all mixture designs before the Contractor can begin production. When shown on the plans, the Engineer will provide the mixture design.

Provide the Engineer with a mixture design report using Department-provided software. Include the following items in the report:

- the combined aggregate gradation, source, specific gravity, and percent of each material used;
- results of all applicable tests;
- the mixing and molding temperatures;
- the signature of the Level II person or persons that performed the design;
- the date the mixture design was performed; and
- a unique identification number for the mixture design.

Table 4
Master Gradation Bands (% Passing by Weight) and Binder Content

Sieve Size		Type A	TypeB	TypeC
(inch)	(mm)	Gradation	Gradation	Gradation
3/4 in.	19			100*
1/2 in.	12.7		100	75-100
3/8 in.	9.5	100	75-100	55-80
4	4.75	35-55	22-36	22-36
8	2.36	19-30	19-30	19-30
16	1.18	14-25	14-24	14-24
30	0.60	10-18	10-18	10-18
50	0.30	7-14	7-14	7-14
100	0.15	5-10	5-10	5-10
200	0.075	4-6	4-6	4-6
AC Content %		5.0-5.8	4.8-5.6	4.6-5.6

* A target of 100% passing the 5/8 in. is recommended. Mixtures containing 5/8 in. aggregate size shall require greater paving thickness.

**Table 5
Laboratory Mixture Design Properties**

Mixture Property	Test Method	Minimum	Maximum
Film Thickness, microns	Tex-247-F	9.0	11.0
Drain-down, %	Tex-235-F	—	0.10
Cantabro Loss (unaged), %	Tex-245-F	—	20.0 ¹
Boil test	Tex-530-C	Pass/Fail	None
Target Membrane Application Rate	Tex-247-F	-	-

1. Test and report for informational purposes only.

1. **Job Mix Formula (JMF) Approval.** The JMF is the combined aggregate gradation and target asphalt percentage used to establish target values for hot mix production. JMF1 is the original laboratory mixture design used to produce the trial batch. The Engineer and the Contractor will verify JMF1 based on plant produced mixture from the trial batch unless otherwise approved. The Engineer may accept an existing mixture design previously used on a Department project and may waive the trial batch to verify JMF1.
 - a. **Contractor's Responsibilities.**
 - (1) **Submitting JMF1.** Furnish the Engineer a mix design report (JMF1) and request approval to produce the trial batch.
 - (2) **Membrane Target Application Rate.** Provide the Engineer the emulsion membrane target application rate calculated from JMF1.
 - (3) **Supplying Aggregates.** Provide the Engineer with approximately 40 lb. of each aggregate stockpile unless otherwise directed.
 - (4) **Supplying Asphalt.** Provide the Engineer at least 1 gal. of the asphalt material and sufficient quantities of any additives proposed for use.
 - (5) **Ignition Oven Correction Factors.** Determine the aggregate and asphalt correction factors from the ignition oven using Tex-236-F. Provide the Engineer with split samples of the mixtures and blank samples used to determine the correction factors.
 - (6) **Boil Test.** Perform the test and retain the tested sample from Tex-530-C. Use this sample for comparison purposes during production. The Engineer may waive the requirement for the boil test. If signs of stripping exist, add lime or commercial antistripping agents (liquid antistrip) as directed.
 - (7) **Trial Batch Approval.** Upon receiving conditional approval of JMF1 from the Engineer, provide a plant-produced trial batch for verification testing of JMF1 and development of JMF2.
 - (8) **Trial Batch Production Equipment.** To produce the trial batch, use only equipment and materials proposed for use on the project.

- (9) **Trial Batch Quantity.** Produce enough quantity of the trial batch to ensure that the mixture is representative of JMF1.
- (10) **Number of Trial Batches.** Produce trial batches as necessary to obtain a mixture that meets the operational tolerances in Table 6.
- (11) **Trial Batch Sampling.** Obtain a representative sample of the trial batch and split it into 3 equal portions in accordance with Tex-222-F. Label these portions as “Contractor,” “Engineer,” and “Referee.” Deliver samples to the appropriate laboratory.
- (12) **Trial Batch Testing.** Test the trial batch to ensure the mixture produced using the proposed JMF1 meets the verification testing requirements for gradation, binder content, laboratory-molded density, and drain-down listed in Table 6. Provide the Engineer with a copy of the trial batch test results.
- (13) **Development of JMF2.** After the Engineer grants full approval of JMF1 based on results from the trial batch, evaluate the trial batch test results, determine the optimum mixture proportions, and submit as JMF2.
- (14) **Mixture Production.** After receiving approval for JMF2, use JMF2 to produce Lot 1.
- (15) **Development of JMF3.** Evaluate the test results from Lot 1, determine the optimum mixture proportions, and submit as JMF3 for use in Lot 2.
- (16) **JMF Adjustments.** If necessary, adjust the JMF before beginning a new lot. The adjusted JMF must:
- be provided to the Engineer in writing before the start of a new lot,
 - be numbered in sequence to the previous JMF,
 - meet the master gradation limits shown in Table 4, and
 - be within the operational tolerances of JMF2 listed in Table 6.
- (17) **Requesting Referee Testing.** If needed, use the referee testing in accordance with Section 4.I.1, “Referee Testing,” to resolve testing differences with the Engineer.

**Table 6
Testing Frequency and Mixture Production Tolerances**

Test Description	Test Method	Minimum Contractor Testing Frequency	Minimum Engineer Testing Frequency	Operational Tolerance from JMF
% Passing for sieve sizes larger than #4	Tex-200-F	1 per subplot	1 per 12 sublots	+5.0
% Passing #4 and #8	Tex-200-F	1 per subplot	1 per 12 sublots	+ 4.0
% Passing #16, #30 and #50	Tex-200-F	1 per subplot	1 per 12 sublots	+3.0
% Passing#100	Tex-200-F	1 per subplot	1 per 12 sublots	+2.0
% Passing #200	Tex-200-F	1 per subplot	1 per 12 sublots	See Note 1
Binder Content, %	Tex-236-F	1 per subplot	1 per lot	±0.3
Film Thickness, microns		1 per lot	1 per 12 sublots	> 9.0
Rice Gravity	Tex 227-F	1 per lot	1 per 12 sublots	See Note 3
Drain-down, %	Tex-235-F	1 per subplot	1 per 12 sublots	Table 5
Boil Test ²	Tex-530-C	1 per project	1 per project	N/A
Membrane Application Rate	Tex-247-F	1 per lot	1 per 12 sublots	+ 0.2
Asphalt Binder Sampling ²	Tex-500-C	1 per subplot (sample only)	1 per project	N/A
Thermal profile	Tex-244-F	1 per subplot	Optional	N/A

1. Aggregate gradation will not exceed limits shown in Table 4.

2. The Engineer may reduce or waive the sampling and testing requirements based on a satisfactory test history.

3. Used to calculate film thickness.

b. Engineer's Responsibilities.

- (1) **Gyratory Compactor.** For molding trial batch samples, the Engineer will use the Contractor-provided SGC at the Contractor's field laboratory or provide and use a Department SGC at an alternate location.
- (2) **Conditional Approval of JMF1.** Within 2 working days of receiving the mixture design report (JMF1) and all required materials, the Engineer will review the Contractor's mixture design report and verify conformance with all aggregates, asphalt, additives, and mixture specifications. The Engineer may perform tests to verify the aggregates meet the requirements listed in Table 1. The Engineer will grant the Contractor conditional approval of JMF1 if the information provided on the paper copy of JMF1 indicates the Contractor's mixture design meets the specifications. Full approval of JMF1 will be based on the Engineer's test results on mixture from the trial batch.
- (3) **Authorizing Trial Batch.** After conditionally approving JMF1, the Engineer will authorize the Contractor to produce a trial batch.
- (4) **Ignition Oven Correction Factor.** The Engineer will use the split samples provided by the Contractor to determine the aggregate and asphalt correction factors for the ignition oven in accordance with Tex-236-F.
- (5) **Testing the Trial Batch.** Within 1 full working day, the Engineer will sample and test the trial batch to ensure that the gradation and binder content meet the requirements listed in Table 6.

The Engineer will have the option to perform the following tests on the trial batch:

- Tex-235-F to verify that drain-down meets the requirement shown in Table 5.
- Tex-461-A to determine the need for additional magnesium sulfate soundness testing.
- Tex-530-C to retain and use for comparison purposes during production.
- Tex-245-F to verify the Cantabro loss meets the requirement shown in Table 5.

- (6) **Full approval of JMF1.** The Engineer will grant full approval of JMF1 and authorize the Contractor to proceed with developing JMF2 if the Engineer's results for gradation and asphalt content confirm that the trial batch meets the requirements in Table 6.

The Engineer will notify the contractor that an additional trial batch is required if the trial batch does not meet the requirements in Table 6.

- (7) **Approval JMF2.** The Engineer will approve JMF2 within 1 working day if it meets the master grading limits shown in Table 4 and is within the operational tolerances of JMF1 listed in Table 6.

- (8) **Approval Lot 1 Production.** The Engineer will authorize the Contractor to proceed with Lot 1 production after approving JMF2.

- (9) **Approval of JMF3.** The Engineer will approve JMF3 within 1 working day if it meets the master grading limits shown in Table 4 and is within the operational tolerances of JMF2 listed in Table 6.

2. **JMF Adjustments.** Produce the mixture within the operational tolerances listed in Table 6. The Engineer may suspend production if corrective actions are not taken when operational tolerances are exceeded. With approval from the Engineer, the JMF target values may be adjusted as needed. Document any changes to the JMF with a subsequent JMF number. The Engineer may adjust the target asphalt percentage within the operational tolerances of the JMF.

- E. **Production Operations.** Perform a new trial batch when the plant or plant location is changed. Perform quality control at the frequency and within the tolerances listed in Table 6. Take corrective action and receive approval to proceed after any production suspension for noncompliance to the specification.

At any time during production the Engineer may require the Contractor to verify the following based on quantities used:

- Additives:
 - lime (within $\pm 0.1\%$ of JMF)
 - liquid anti-strip (within $\pm 0.05\%$ of JMF)
- Emulsion membrane application rate

If the aggregate mineralogy is such that Tex-236-F does not yield reliable results, the Engineer may allow alternate methods for determining the asphalt content and aggregate gradation. Unless otherwise allowed, the Engineer will require the Contractor to provide evidence that results from Tex-236-F are not reliable before permitting an alternate method. If an alternate test method is allowed, use the applicable test procedure as directed.

1. **Storage and Heating of Materials.** Do not heat the asphalt binder above the temperatures specified in Item 300, "Asphalts, Oils, and Emulsions" or from the manufacturer's recommended values. On a daily basis, provide the Engineer with the records of asphalt binder and hot mix asphalt discharge temperatures in accordance with Section 3.A.1.c. "Heating, Drying, and Mixing Systems". Unless otherwise approved, do not store hot mix for more than 6 hrs. or a time period that affects the quality of the mixture.
2. **Mixing and Discharge of Materials.** Notify the Engineer of the target discharge temperature and produce the mixture within 25°F of the target. Monitor the temperature of the material in the truck before shipping to ensure that it does not exceed 350°F. The Department will not pay for or allow placement of any mixture produced at more than 350°F.

Control the mixing time and temperature so that substantially all moisture is removed from the mixture before discharging from the plant. If requested, perform Tex-212-F, Part II, and verify that the mixture contains no more than 0.2% of moisture by weight. Obtain the sample immediately after discharging the mixture into the truck and perform the test promptly.

- F. **Hauling Operations.** Before use, clean all truck beds to ensure mixture is not contaminated. When a release agent is necessary, use a release agent on the approved list maintained by the Construction Division to coat the inside bed of the truck.
- G. **Placement Operations.** Prepare the surface by removing raised pavement markers and objectionable material such as moisture and dirt, sand, leaves, and other loose impediments from the surface before placing mixture. Remove vegetation from pavement edges. Use an approved paver to concurrently apply the membrane and place the UTBHMWC mixture to produce a smooth, finished surface with a uniform appearance and texture that meet typical section requirements. Control the speed of the paver to insure that the membrane is exposed for no more than 5 seconds before being covered with UTBHMWC. Place mixture so longitudinal joints on the surface course coincide with lane lines, or as directed. Place the hot mix adjacent to gutters and structures so that the pavement will drain properly.
1. **Weather Conditions.** Place the mixture when the roadway surface temperature is 70°F or higher unless otherwise approved. Measure the roadway surface temperature with a handheld infrared thermometer. Place mixtures only when general weather conditions and moisture conditions of the roadway surface are suitable in the opinion of the Engineer.
 2. **Application of Membrane.** Unless otherwise directed by the Engineer, apply the membrane at the rates shown in Table 7. Adjust the application rate taking into

consideration the existing pavement surface conditions and the void structure of the UTBHMWC. Spray the membrane using a metered mechanical pressure spray bar at a temperature of 120°F to 180°F. Monitor the membrane application rate and make adjustments to the rate when needed or when directed. If required, verify that the spray bar is capable of applying the membrane at a uniform rate across the entire paving width as directed. Do not let the wheels or other parts of the paving machine contact the freshly applied membrane.

Table 7
Membrane Target Application Rates¹, (gallons per square yard)

Type A ²	Type B ²	Type C ²
0.14 – 0.19	0.17 – 0.24	0.20 – 0.27

1. Adjust the application rate taking into consideration the existing pavement surface conditions and the void structure of the UTBHMWC.
2. Do not exceed operational tolerance listed in Table 6.

3. **Lay-Down Operations.** Measure the temperature of mixture delivered to the paver and take corrective action if needed to insure the temperature does not drop below 290°F.

For each subplot use a handheld infrared thermometer to obtain a thermal profile of the uncompacted mat immediately behind the paver. Record the information on Department QCQA forms and submit the forms to the Engineer. The Engineer may reduce the testing frequency based on a satisfactory test history.

- a. **Thermal Profile.** For each subplot, obtain a thermal profile using Tex-244-F. The Engineer may also obtain as many thermal profiles as deemed necessary.

No more than a 50°F differential will be allowed along the profile of the uncompacted mat surface immediately behind the paver. Unless otherwise directed, suspend operations and remove and replace material that exceeds the maximum temperature differential of 50°F. Resume operations when the Engineer determines that subsequent production will meet the specifications.

If the temperature differential is between 25°F and 50°F, the area will be deemed as having thermal segregation. Take corrective action to eliminate areas that have thermal segregation.

- H. **Compaction.** Roll the freshly placed UTBHMWC with a steel-wheeled roller, operated in static mode, to seat the mixture without excessive breakage of the aggregate and to provide a smooth surface and uniform texture. Compact the wearing course a minimum of 2 passes and a maximum of 3 passes. Do not use pneumatic rollers. Thoroughly moisten the roller drums with a soap and water solution to prevent adhesion. Unless otherwise directed, use only water or a Department-approved release agent on rollers, tamps, and other compaction equipment.

The Engineer may use, or require the Contractor to use, Tex-246-F to test and verify that the compacted mixture has adequate permeability. Adjust the mixture design or construction methods if the compacted mixture does not exhibit adequate permeability.

Allow the compacted pavement to cool to 160°F or lower before opening to traffic unless otherwise directed.

Acceptance Plan. Sample and test the hot mix on a lot and subplot basis. A production lot consists of 4 equal sublots. Lot 1 will be 500 tons or one days production. The Engineer will select subsequent lot sizes based on the anticipated daily production. The lot size will be at least 500 tons, but no greater than 2000 tons. The Engineer may change the lot size before the Contractor begins any lot. If the production or placement test results are not within the acceptable tolerances listed in Table 6, suspend production until test results or other information indicate, to the satisfaction of the Engineer, that the next material produced or placed will meet the specified values.

1. Referee Testing. The Construction Division is the referee laboratory. The Contractor may request referee testing if the differences between Contractor and Engineer test results exceed the operational tolerances shown in Table 6 and the differences cannot be resolved. Make the request within 5 working days after receiving test results and cores from the Engineer. Referee tests will be performed only on the subplot in question and only for the particular test in question. Allow 10 working days from the time the samples are received at the referee laboratory for test results to be reported. The Department may require the Contractor to pay for additional referee tests if more than 3 referee tests per project are required and the Engineer's test results are closer to the referee test results than the Contractor's test results.

2. Asphalt Binder Sampling. Obtain a 1-qt. sample of the asphalt binder for each subplot of mixture produced. Obtain the sample at approximately the same time the mixture random sample is obtained. Supply a sampling port between any additive blending device and mixer. Locate the sampling port downstream of any additive addition so the sample will be a representation of the final asphalt-additive blend going to the roadway. Sample from a port located immediately upstream from the mixing drum or pug mill. Take the sample in accordance with Tex-500-C, Part II. Label the can with the corresponding lot and subplot numbers, and deliver the sample to the Engineer.

The Engineer may also obtain independent samples. If the Engineer chooses to obtain an independent asphalt binder sample, the Engineer will split a sample of the asphalt binder with the Contractor. The Engineer will test at least 1 asphalt binder sample per project to verify compliance with Item 300.

3. Polymer Modified Emulsion Membrane. Obtain a 1-qt. sample of the polymer modified emulsion for each subplot of mixture produced. Take the sample from the emulsion tank located on the paving machine, but not from the emulsion spraybar. Obtain the sample at approximately the same time the mixture random sample is obtained. Take the sample in accordance with Tex-500-C, Part III. Label the can with the corresponding lot and subplot numbers, and deliver the sample to the Engineer.

4. Operational Tolerances. Control the production process within the operational tolerances listed in Table 6. When production is suspended, the

Engineer will allow production to resume when test results or other information indicates the next mixture produced will be within the operational tolerances.

5. Recovered Asphalt DSR. The Engineer may take production samples or cores from suspect areas of the project to determine recovered asphalt properties. Asphalt binders with an aging ratio greater than 3.5 do not meet the requirements for recovered asphalt properties and may be deemed defective when tested and evaluated by the Construction Division. The aging ratio is the dynamic shear rheometer (DSR) value of the extracted binder divided by the DSR value of the original unaged binder. DSR values are obtained according to AASHTO T315 at the specified high temperature performance grade of the asphalt. The Engineer may require removal and replacement of the defective material at the Contractor's expense. The asphalt binder will be recovered for testing from production samples or cores using Tex-211-F.

6. Irregularities. Immediately take appropriate corrective actions if surface irregularities, including but not limited to segregation, rutting, raveling, flushing, fat spots, mat slippage, color, texture, roller marks, tears, gouges, streaks, or uncoated aggregate particles, are detected. The Engineer may allow placement to continue for at most 1 day of production while taking appropriate action. If the problem still exists after that day, suspend paving until the problem is corrected to the satisfaction of the Engineer.

At the expense of the Contractor and to the satisfaction of the Engineer, remove and replace any mixture that does not bond to the existing pavement or has other surface irregularities identified above.

7. Ride Quality. Unless otherwise shown in the plan, measure ride quality in accordance with Item 585, "Ride Quality for Pavement Surfaces"

5. Measurement. Ultra Thin-Bonded Hot Mix Wearing Course (UTBHMWC) will be measured by the ton of UTBHMWC. UTBHMWC is defined as the, asphalt, aggregate, and additives. The weights of asphalt and aggregate will be calculated based on the measured weight of UTBHMWC and the target percentage of asphalt and aggregate. Measure on scales in accordance with Item 320, "Equipment for Asphalt Concrete Pavement." The UTBHMWC polymer modified emulsion membrane will be measured by the gallon.

A. Membrane. Unless otherwise noted on the plans, membrane material will be measured by one of the following methods:

1. Volume. Membrane material will be measured at the applied temperature by strapping the tank before and after road application and determining the net volume in gallons from the distributor's calibrated strap stick. The quantity to be measured for pavement will be the number of gallons used corrected to 60°F, as directed, in the accepted surface treatment.

2. Weight. Membrane material will be measured in tons using certified scales meeting the requirements of Item 320, "Equipment for Asphalt Concrete Pavement," unless otherwise approved. The transporting truck must have a seal attached to the

driving device and other openings. The Engineer may require random checking on public scales, at the Contractor's expense, to verify weight accuracy.

Upon work completion or temporary suspension, any remaining membrane material will be weighed by a certified public weigher, or measured by volume in a calibrated distributor or tank and the quantity converted to tons at the measured temperature. The quantity to be measured will be the number of tons received, minus the number of tons remaining after all directed work is complete, and minus the amount used for other items.

B. Asphalt. The asphalt weight in tons will be determined from the total weight of UTBHMWC. Measured asphalt percentage will be obtained using Tex-236-F or asphalt flow meter readings, as determined by the Engineer.

1. Target Percentage. The JMF target asphalt percentage will be used to calculate the weight of asphalt binder unless the measured asphalt binder percentage is more than 0.3 percentage points below the JMF target asphalt percentage. Volumetric meter readings will be adjusted to 60°F and converted to weight.

2. Measured Percentage. The measured asphalt percentage will be used for payment for that lot's production when the measured percentage is more than 0.3 percentage points below the JMF target asphalt percentage.

C. Aggregate. The aggregate weight in tons will be determined from the total weight of UTBHMWC less the weight of the asphalt.

6. Payment. The work performed and materials furnished in accordance with this Item and measured as provided under "Measurement," will be paid for at the unit price bid for "UTBHMWC (Membrane)," for "UTBHMWC (Asphalt)," and for "UTBHMWC (Aggregate)" of the types specified. These prices are full compensation for all materials, equipment, labor, tools, and incidentals.

Trial batches will not be paid for unless they are included in pavement work approved by the Department.

SPECIAL SPECIFICATION (ADDENDUM)

3001

Ultra – Thin Bonded Hot Mix Wearing Course (UTBHMWC)

The following information provides requirements for aggregate to be used for the project.

Aggregate Source:

Uvalde Texas: Vulcan Materials – Knippa Quarry and Martin Marietta – Bird Hill Quarry

Aggregate Type:

Black basalt rock

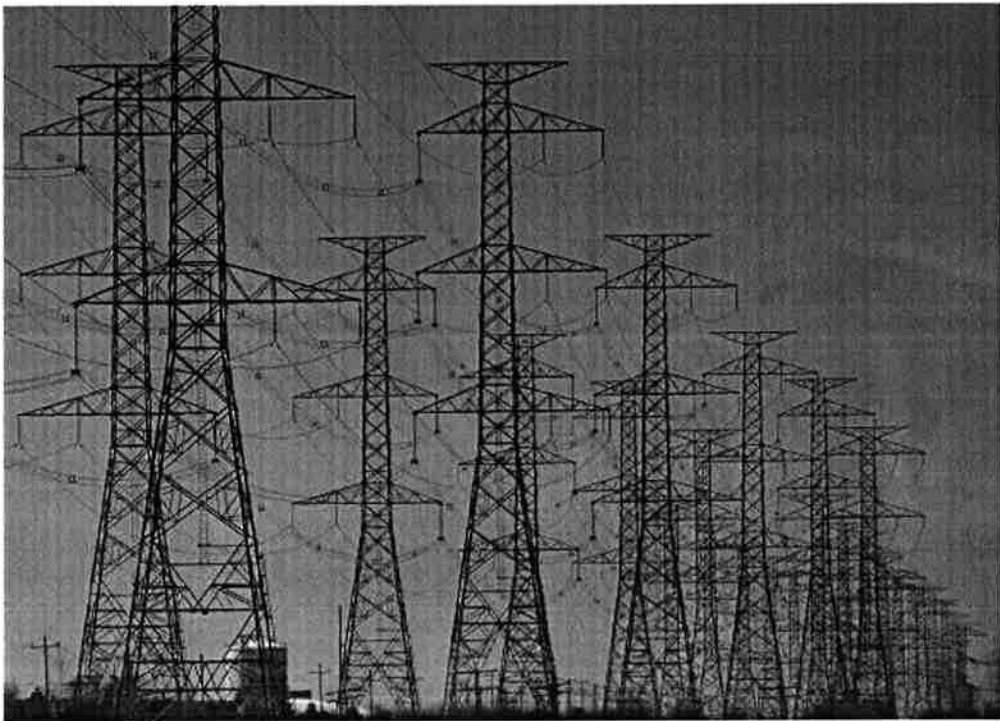

Guidelines for Use of Company Property by Others

Oncor Electric Delivery Company Policy

It is the policy of Oncor to not unreasonably withhold the granting of easements, rights-of-way and licenses on its real estate property for street, road, utility and drainage crossings, and other approved uses. **The following set of guidelines are intended to state Oncor Electric Delivery Company's general policy for use of its right of way by others and are not all inclusive in nature nor do they imply approval of any kind by Oncor.** Each request for use is reviewed individually, and must be approved by Transmission Engineering, Transmission Operating, Distribution Engineering, Transmission Planning and any other Company organization having a vested interest in the request. Approval must be obtained from all organizations in order to grant the request.

All requests should be addressed to Oncor Electric Delivery Company, Right of Way, 115 W. 7th Street, Suite 1125, Fort Worth TX 76102. Each request should be accompanied by a description of the rights sought, surveys, maps, drawings, statement of purpose and any other information deemed necessary. A \$250 non-refundable administration fee, paid at the time of the request, is charged to cover Company review and document preparation. An application form for use of Oncor Right of Way will be furnished upon request.

Fee Simple Property

Easement rights for crossings of Oncor fee owned rights-of-way that do not interfere with the construction, reconstruction, operation and maintenance of Oncor facilities may be granted if the crossing is not less than 45 degrees to the centerline of the right-of-way.



Fees will be based on county appraisal values.

Fire Lanes are not included in crossings and will be considered only when crossing at 90 degrees. Each **Fire Lane** request will be reviewed individually for approval.

Longitudinal rights will not be granted for the placement of utilities, roads, pipelines, fences, or other uses along Oncor rights-of-way.

Licenses for parking, agricultural, and other surface uses may be granted provided the applicant is the adjacent landowner. The license will be personal, revocable and non-assignable. Licenses for parking will be granted for over flow parking only; **no code required parking will be allowed**. The licensee will be responsible for all mowing and maintenance of the right-of-way affected by the licensed area.

Fees for easements and licenses will be based on county appraisal values of adjacent properties.

Easement Right of Way

Encroachment by third parties on Oncor easement rights-of-ways that meet the above criteria for approval may be granted by an Encroachment Agreement. The proposed user will be required to obtain whatever rights and permission, other than Oncor's that are necessary from the property owner.

Construction Limitations

When a request is granted, Right of Way Services will prepare the appropriate document for signatures by Oncor and the grantee. In addition to the provisions of the Agreement, the approved facility will be subject to the following construction limitations:

1. You are notified, and should advise your employees, representatives, agents, and contractors, who enter the property that they will be working in the vicinity of high voltage electrical facilities and should take proper precautions, included but not limited to the following stipulations and in compliance, at all times, with Chapter 752, V.T.C.A., Health & Safety Code.
2. Blasting is not to be permitted on Oncor right-of-way or under Oncor lines.

3. Construction on electric transmission line easements acquired by Oncor after January 1, 2003 shall comply with the requirements of Public Utility Commission Substantive Rules §25.101, as amended from time to time.
4. Grading will be done in order to leave the right-of-way as near as possible to present condition. Spoil dirt will be removed from the right-of-way and no trash is to be left on right-of-way. Slopes shall be graded so that trucks can go down the right-of-way when required and such that they can be mechanically maintained.
5. Equipment and materials will not be stored on the right-of-way during construction without written approval of the Supervisor of Regional Transmission.
6. Street or road crossings are to be based on drawings submitted. Any change in alignment or elevation will be resubmitted for approval.
7. Runways or air take off and landing strips are not permitted on the right-of-way.
8. No signs, lights or guard lights will be permitted on the right-of-way.
9. Equipment shall not be within fifteen (15) feet of the lowest conductor.
10. Any pre-approved fencing will not exceed eight (8) feet in height, and if metal in nature, will be grounded, at ten (10) feet intervals, with an appropriate driven ground. Gates should be at least sixteen (16) feet in width to allow Oncor access to the right-of-way.
11. No dumpsters will be allowed on Oncor right-of-way or fee owned property.
12. Drag lines will not be used under the line or on Oncor right-of-way.
13. The existing grade shall not be disturbed, excavated or filled within 25 feet of the nearest edge of any tower.
14. Right-of-way will be protected from washing and erosion by Oncor approved method before any permits are granted.
15. No obstruction shall be installed on the right-of-way that would interfere with access to Oncor structures or prevent mechanical maintenance.
16. Before any work is done under Oncor lines or by Oncor structures notify the Region Transmission Department.
17. No hazardous materials will be stored on the right of way.
18. For purposes of this document, "Hazardous Materials" means and includes those substances, including, without limitation, asbestos-containing material containing more than one percent (1%) asbestos by weight, or the group of organic compounds known as polychlorinated biphenyls, flammable explosives, radioactive materials, chemicals known to cause cancer or reproductive toxicity and includes any items included in the definition of hazardous or toxic waste, materials or substances under any Hazardous Material Law. "Hazardous Material Laws" collectively means and includes any present and future local, state and federal law relating to the environment and environmental conditions including, without limitation, the Resource Conservation and Recovery Act of 1976 ("RCRA"), 42 U.S.C. §6901 *et seq.*, the Comprehensive Environmental Response, Compensation and Liability Act of 1980, ("CERCLA"), 42 U.S.C. §§9601-9657, as amended by the Superfund Amendments and Reauthorization Act of 1986 ("SARA"), the Hazardous Material Transportation Act, 49 U.S.C. §6901 *et seq.*, the Federal Water Pollution Control Act, 33 U.S.C. §1251, *et seq.*, the Clean Air Act, 42 U.S.C. §741 *et seq.*, the Clean Water Act, 33 U.S.C. §7401 *et seq.*, the Toxic Substances Control Act, 15 U.S.C. §§2601-2629, the Safe Drinking Water Act, 42 U.S.C. §§300f-330j, and all the regulations, orders, and decrees now or hereafter promulgated thereunder.
19. Brush and cut timber will not be piled or stacked on Oncor right-of-way or will not be burned upon or in close proximity to the conductors or towers.
20. No structures or obstructions, such as buildings, garages, barns, sheds, guard houses, etc., will be permitted on the right-of-way.

Landscaping on Oncor Right of Way

Landscaping on Oncor right-of-way is permitted when landscaping plans are approved in writing by Oncor.

No lighting or sprinkler systems are allowed on the right-of-way.

The following is a list of typical trees permitted on the right-of-way. In no case shall a tree with a mature height of more than 15 feet be permitted.

Texas Mountain Laurel – *Sophora secundiflora*

Japanese Maple – *Acer palmatum* var.

Yaupon Holly – *Ilex vomitoria*

Rusty Black Haw – *Viburnum rufidulum*

Flame Leaf Sumac – *Rhus lanceolata*

Rough-leaf Dogwood – *Cornus drummondii*

Vitex – *Vitex angus-castus*

Mexican Plum – *Prunus Mexicana*

Viburnam – *Viburnam* spp.

Chinese Photinia – *Photinia serrulata*

Texas Persimmon – *Diospyros texana*

Mexican Buckeye – *Ungnadia speciosa*

Peach – *Prunus persica*

Possumhaw – *Ilex decidua*

Right of Way

Suite 1125

115 W. 7th Street

Fort Worth, Texas 76102

817.898.4ROW

817.898.4769

CONSTRUCTION LIMITATIONS
ON ONCOR ELECTRIC DELIVERY COMPANY RIGHT OF WAY
EXHIBIT "B"

1. You are notified, and should advise your employees, representatives, agents, and contractors, who enter the property that they will be working in the vicinity of high voltage electrical facilities and should take proper precautions, included but not limited to the following stipulations and in compliance, at all times, with Chapter 752, V.T.C.A., Health & Safety Code.
2. Blasting is not to be permitted on ONCOR right-of-way or under ONCOR lines.
3. Construction on electric transmission line easements acquired by ONCOR after January 1,2003 shall comply with the requirements of Public Utility Commission Substantive Rules §25.101, as amended from time to time.
4. Grading will be done in order to leave the right-of-way as near as possible to present condition. Spoil dirt will be removed from the right-of-way and no trash is to be left on right-of-way. Slopes shall be graded so that trucks can go down the right-of-way when required and such that the slopes can be mechanically maintained.
5. Equipment and materials will not be stored on the right-of-way during construction without written approval of the Supervisor of Regional Transmission.
6. Street or road crossings are to be based on drawings submitted. Any change in alignment or elevation will be resubmitted for approval.
7. No signs, lights or guard lights will be permitted on the right-of-way.
8. Equipment shall not be placed within fifteen (15) feet of the power lines.
9. Any pre-approved fencing will not exceed eight (8) feet in height, and if metal in nature, will be grounded, at ten (10) feet intervals, with an appropriate driven ground. Gates should be at least sixteen (16) feet in width to allow ONCOR access to the right-of-way.

10. No dumpsters will be allowed on ONCOR right-of-way or fee owned property.
11. Draglines will not be used under the line or on ONCOR right-of-way.
12. The existing grade shall not be disturbed, excavated or filled within 25 feet of the nearest edge of any tower.
13. Right-of-way will be protected from washing and erosion by ONCOR approved method before any permits are granted. No discharging of water will be allowed within any portion of the right of way.
14. No obstruction shall be installed on the right-of-way that would interfere with access to ONCOR structures or prevent mechanical maintenance.
15. Before any work is done under ONCOR lines or by ONCOR structures notify the Region Transmission Department, (817) 496-2731, or (817) 496-2736.
16. No hazardous materials will be stored on the right of way.
17. For purposes of this document, "Hazardous Materials" means and includes those substances, including, without limitation, asbestos-containing material containing more than one percent (1%) asbestos by weight, or the group of organic compounds known as polychlorinated biphenyls, flammable explosives, radioactive materials, chemicals known to cause cancer or reproductive toxicity and includes any items included in the definition of hazardous or toxic waste, materials or substances under any Hazardous Material Law.
"Hazardous Material Laws" collectively means and includes any present and future local, state and federal law relating to the environment and environmental conditions including, without limitation, the Resource Conservation and Recovery Act of 1976 ("RCRA"), 42 U.S.C. §6901 et seq., the Comprehensive Environmental Response, Compensation and Liability Act of 1980, ("CERCLA"), 42 U.S.C. §§9601-9657, as amended by the Superfund Amendments and Reauthorization Act of 1986 ("SARA"), the Hazardous Material Transportation Act, 49 U.S.C. §6901 et seq., the Federal Water Pollution Control Act, 33 U.S.C. §1251, et seq., the Clean Air Act, 42 U.S.C. §741 et seq., the Clean Water Act, 33 U.S.C. §7401 et seq., the Toxic Substances Control Act, 15 U.S.C. §§2601-2629, the Safe

Drinking Water Act, 42 U.S.C. §§300f-330j, and all the regulations, orders, and decrees now or hereafter promulgated thereunder.

18. Brush and cut timber will not be piled or stacked on ONCOR right-of-way or will not be burned upon or in close proximity to the conductors or towers.
19. No structures or obstructions, such as buildings, garages, barns, sheds, guard houses, etc., will be permitted on the right-of-way.
20. Landscaping on ONCOR right-of-way is permitted when ONCOR approves landscaping plans in writing. No lighting or sprinkler systems are allowed on the right-of-way.

CONSTRUCTION LIMITATIONS
ON ONCOR ELECTRIC DELIVERY COMPANY RIGHT OF WAY
EXHIBIT "B"

1. You are notified, and should advise your employees, representatives, agents, and contractors, who enter the property that they will be working in the vicinity of high voltage electrical facilities and should take proper precautions, included but not limited to the following stipulations and in compliance, at all times, with Chapter 752, V.T.C.A., Health & Safety Code.
2. Blasting is not to be permitted on ONCOR right-of-way or under ONCOR lines.
3. Construction on electric transmission line easements acquired by ONCOR after January 1,2003 shall comply with the requirements of Public Utility Commission Substantive Rules §25.101, as amended from time to time.
4. Grading will be done in order to leave the right-of-way as near as possible to present condition. Spoil dirt will be removed from the right-of-way and no trash is to be left on right-of-way. Slopes shall be graded so that trucks can go down the right-of-way when required and such that the slopes can be mechanically maintained.
5. Equipment and materials will not be stored on the right-of-way during construction without written approval of the Supervisor of Regional Transmission.
6. Street or road crossings are to be based on drawings submitted. Any change in alignment or elevation will be resubmitted for approval.
7. No signs, lights or guard lights will be permitted on the right-of-way.
8. Equipment shall not be placed within fifteen (15) feet of the power lines.
9. Any pre-approved fencing will not exceed eight (8) feet in height, and if metal in nature, will be grounded, at ten (10) feet intervals, with an appropriate driven ground. Gates should be at least sixteen (16) feet in width to allow ONCOR access to the right-of-way.

10. No dumpsters will be allowed on ONCOR right-of-way or fee owned property.
11. Draglines will not be used under the line or on ONCOR right-of-way.
12. The existing grade shall not be disturbed, excavated or filled within 25 feet of the nearest edge of any tower.
13. Right-of-way will be protected from washing and erosion by ONCOR approved method before any permits are granted. No discharging of water will be allowed within any portion of the right of way.
14. No obstruction shall be installed on the right-of-way that would interfere with access to ONCOR structures or prevent mechanical maintenance.
15. Before any work is done under ONCOR lines or by ONCOR structures notify the Region Transmission Department, (817) 496-2731, or (817) 496-2736.
16. No hazardous materials will be stored on the right of way.
17. For purposes of this document, "Hazardous Materials" means and includes those substances, including, without limitation, asbestos-containing material containing more than one percent (1%) asbestos by weight, or the group of organic compounds known as polychlorinated biphenyls, flammable explosives, radioactive materials, chemicals known to cause cancer or reproductive toxicity and includes any items included in the definition of hazardous or toxic waste, materials or substances under any Hazardous Material Law.
"Hazardous Material Laws" collectively means and includes any present and future local, state and federal law relating to the environment and environmental conditions including, without limitation, the Resource Conservation and Recovery Act of 1976 ("RCRA"), 42 U.S.C. §6901 et seq., the Comprehensive Environmental Response, Compensation and Liability Act of 1980, ("CERCLA"), 42 U.S.C. §§9601-9657, as amended by the Superfund Amendments and Reauthorization Act of 1986 ("SARA"), the Hazardous Material Transportation Act, 49 U.S.C. §6901 et seq., the Federal Water Pollution Control Act, 33 U.S.C. §1251, et seq., the Clean Air Act, 42 U.S.C. §741 et seq., the Clean Water Act, 33 U.S.C. §7401 et seq., the Toxic Substances Control Act, 15 U.S.C. §§2601-2629, the Safe

Drinking Water Act, 42 U.S.C. §§300f-330j, and all the regulations, orders, and decrees now or hereafter promulgated thereunder.

18. Brush and cut timber will not be piled or stacked on ONCOR right-of-way or will not be burned upon or in close proximity to the conductors or towers.
19. No structures or obstructions, such as buildings, garages, barns, sheds, guard houses, etc., will be permitted on the right-of-way.
20. Landscaping on ONCOR right-of-way is permitted when ONCOR approves landscaping plans in writing. No lighting or sprinkler systems are allowed on the right-of-way.

WATER SYSTEM REQUIREMENTS

WATER SYSTEM REQUIREMENTS

I. GENERAL:

- A. Design criteria for all water systems shall comply with Texas Commission on Environmental Quality (TCEQ) Chapter 290 (Rules and Regulations for Public Water Systems), latest revision.
- B. Permits from agencies other than the town must be submitted through the town.
- C. The Engineer shall include on the design plans a summary of pipe sizes, pipe materials, and joint materials.
- D. Profile elevations shall be provided for mains twelve-inch (12") in diameter and larger. Eight-inch (8") mains may be required to be profiled by the Public Works Department.
- E. Where applicable, line sizes shall comply with the Water Distribution System Master Plan or subsequent revisions.
- F. Water mains shall be sized and extended through the limits of a development to serve adjacent properties. In phased construction of thoroughfares, the water main shall be extended the entire length of the thoroughfare being constructed.

II. WATER MAIN LOCATION:

- A. Water mains in right-of-way shall be installed in the street at five feet (5') from the face of curb on the opposite side of the wastewater main, or otherwise as directed by the Public Works Department.
- B. Water mains shall be located at least five feet (5') from any tree, unless approved by the Public Works Department.
- C. Water mains installed under creeks or ditches shall be protected by concrete encasement a minimum of ten feet (10') past the toe of the embankment on each side or otherwise as directed by the Public Works Department.
- D. Water mains crossing under storm sewers shall have a minimum of eighteen inches (18") clearance below storm sewers. One segment of the water pipe shall be equidistant from the center line of the storm sewer.
- E. Where a new water main crosses over a new non-pressure rated wastewater main or lateral, one segment of the water main shall be centered over the sanitary sewer main and there shall be a minimum of twenty-four inches (24") of clearance or otherwise as governed by TCEQ Chapter 290 requirements.
- F. Where a new water main crosses under a new non-pressure rated wastewater main or lateral, the water main shall be encased in high density steel pipe in accordance with the Town of Addison Standard Construction Details and there shall be a minimum of six inches (6") of clearance or otherwise as governed by TCEQ Chapter 290 requirements.

III. WATER MAIN SIZING:

- A. All water mains shall be a minimum of eight inches (8") in diameter or otherwise as shown on the Water Master Plan.

- B. Six-inch (6") fire hydrant leads shall not exceed one hundred feet (100') unless otherwise allowed by the Public Works Department.
- C. Water mains shall be extended to provide water to adjacent property as directed by the Public Works Department.
- D. Dead end mains are not permitted unless otherwise allowed by the Public Works Department. For dead end mains allowed by the Public Works Department, a fire hydrant shall be installed at the end of the main for use by the Public Works Department.

IV. WATER MAIN MATERIALS:

- A. All water mains twelve-inch (12") in diameter and smaller shall be AWWA C-900 PVC Pressure pipe with cast iron O.D. or when pipe penetrates meter vault walls it shall be ductile iron. Pipe joints shall be rubber ring and integral thickened bell, assembled with a factory supplied lubricant. Water mains shall have a minimum class rating of 165-psi for domestic use and a minimum class rating of 235-psi for fire line and hydrant lead applications. Joint material for PVC shall conform to ASTM F471.
- B. All mains crossing under existing roadway must be installed by bore or otherwise as approved by the Public Works Department. Rust resistant steel casing minimum one-fourth-inch (1/4") thick shall be used with Raci patented casing spacers, or approved equal. No wood skids will be allowed.
- C. All fittings shall be ductile iron, full bodied, mechanical joint type with restraining glands and have a minimum rated working pressure of 250 psi and be manufactured in the United States. Fittings shall be wrapped with 8-mil poly prior to backfill. Compact fittings shall not be permitted unless otherwise allowed by the Public Works Department.
- D. All valves and fittings shall have concrete thrust blocks installed. Thrust blocking shall be minimum 3000 psi concrete and be able to withstand a minimum 200 psi test pressure.
- E. All mains supplying fire sprinkler systems outside of utility easements shall be minimum 200 psi working pressure and U.L. listed.
- F. Connections where the existing main is one or more sizes larger than the proposed main can be made with a full body stainless steel tapping sleeve and valve. In order to maintain a manageable parts inventory and working knowledge of tapping sleeve and valves, the following tapping sleeves are approved: Mueller, Ford and Smith Blair.
- G. Connections to existing lines twenty-inch (20") or larger are not permitted unless allowed by the Public Works Department.

V. WATER MAIN CONSTRUCTION:

- A. Line and grade stakes for construction of all water mains and services shall be furnished by the developer's Engineer or their designated representative. Property lines and corners must be properly staked to ensure correct alignment. The Town will not be liable for improper alignment or delay of any kind caused by improper or inadequate surveys by the developer or by interference of other utilities.
- B. Waterlines shall be tested both bacteriologically and hydrostatically. Water mains shall be hydrostatically tested at 150 psi for four (4) hours. Fire lines shall be hydrostatically tested at 200 psi for two (2) hours.
- C. All bleeder lines shall be removed upon completion of testing by removing the corporation stop and installing a brass plug in the tapping saddle.

VI. TRENCH REQUIREMENTS:

- A. Embedment shall comply with NCTCOG Class "B+" embedment. A layer of geo-textile fabric shall be placed on top of the stone prior to the placement of the select or granular material. Finish backfill shall be native soil free of all rocks and clods greater than three inches (3") in diameter, compacted in six-inch (6") maximum loose lifts to a minimum of 95% Standard Proctor Density at zero to three percent (3%) of optimum moisture. Trenches under pavement may be backfilled with flowable fill with a minimum compressive strength of 400psi to the level indicated by the pavement thickness with the approval of the Public Works Department. A batch design shall be submitted for any flowable fill used within the public rights-of-way.
- B. Locator tape shall be placed on top of the sand embedment.
- C. The minimum cover to the top of the pipe shall be as follows:
 - 1. Lines larger than sixteen-inch (16") shall have a minimum of six feet (6') of cover.
 - 2. Sixteen-inch (16") mains shall have a minimum cover of five feet (5').
 - 3. Twelve-inch (12") and smaller mains shall have a minimum cover of four feet (4').

VII. THRUST BLOCK REQUIREMENTS:

- A. Concrete for blocking shall be class "B"
- B. Pour concrete for block against undisturbed earth.
- C. All anchor fittings to be concrete against thrust blocked. All ductile cast iron fittings and/or pipe to be polywrapped prior to pouring the thrust block.
- D. Concrete shall not extend beyond joints.

VIII. VALVES:

- A. Valves sixteen-inch (16") and under will be Resilient Seat Gate Valves (RSGV). All gate valves shall be of the resilient wedge type conforming AWWA C509, Standard for Resilient Seated Gate Valves, in its most current revision. In addition, all valves shall include the following design criteria:
 - 1. In order to maintain a manageable parts inventory and working knowledge of valves, the following resilient seated gate valves are approved: Mueller A2360, AFC 2500 and AVK Series 25.
 - 2. Wedge shall be cast or ductile iron, fully encapsulated in synthetic rubber.
 - 3. Wedge rubber shall be molded in place and permanently bonded to the iron without screws, rivets or similar fasteners.
 - 4. Wedge shall seat against seating surfaces arranged symmetrically about the centerline of the operating stem, so that seating is equally effective regardless of the direction of pressure imbalance across the wedge.
 - 5. Valves for underground installations shall be non-rising stem type, opening counter-clockwise by means of a two-inch (2") square operating nut. Valves for installation in a vault shall be of the

rising stem type opening counter-clockwise by means of a hand wheel. The word "OPEN" and an arrow indicating direction to open shall be cast in the metal of the nut or hand wheel.

6. Stem shall be sealed by at least two O-rings. All stem seals shall be replaceable with the valve fully open and while subject to full rated pressure.
 7. All nuts and bolts shall be stainless steel.
 8. The waterway shall be smooth and shall have no depressions or cavities in the seat area where foreign material can lodge and prevent closure. The waterway shall be large enough to accept full size tapping cutter without damaging the interior of the valve.
 9. The valve body and bonnet shall be epoxy coated, inside and out, with fusion-bonded epoxy. Coating shall conform to AWWA C550-90, Standard for Protective Interior Coatings for Valves and Hydrants.
- B. Valves shall be placed in such a manner as to require preferably two (2), but not more than three (3) valves to shut down each segment, or as may be required to prevent shutting off more than one fire hydrant/service or no more than fifteen (15) residences in a single family residential district.
- C. Valves shall be placed at or near the ends of mains in such a manner that a shut down can be made for a future main extension without causing loss of service on the existing main. A minimum of twenty feet (20') of main shall be installed past the valve.
- D. Where four-inch (4") or larger fire lines are connected to town water lines, valves shall be installed on each side of the connection and on the fire line.
- E. Valve boxes shall be provided for buried valves. These boxes shall be three (3) piece screw type cast iron of the extension type and shall be Mueller No. H-10360, Bass & Hayes 3 piece adjustable screw type, or East Jordan Iron Works 8560 with 6800 lid, or approved equal. The three (3) pieces shall consist of the top section, bottom section and cover.
- F. Valve boxes located outside of paved areas require a reinforced concrete block twenty-four-inch by twenty-four-inch by six-inch (24" x 24" x 6") flush with finished grade.
- G. All valves shall be marked with a saw or stamp on the curb or pavement with a "V". The "V" shall point to the location of the valve as follows: If the valve is in the paving, the "V" shall be marked upright; if the valve is outside the paving, the "V" shall be marked upside down.
- H. Valves over five feet (5') deep will require extensions, or otherwise as directed by the Public Works Department.

IX. FIRE HYDRANTS:

All fire hydrants installed for use in the Town of Addison shall meet or exceed AWWA Standard C502-85 or the latest revision thereof. Fire hydrants shall have a 5¼" minimum valve opening. Rated working pressure shall be at least 150psi; test pressure shall be 300psi and hydrant capable of flowing 1000gpm (Class A). All hydrants shall be manufactured in the United States and shall be manufacturer's best grade. Hydrant shall be warranted by the manufacturer for a minimum of 5 years. In addition, all hydrants shall include the following design criteria:

A. General Design

1. In order to maintain a manageable parts inventory and working knowledge of fire hydrants, the

following hydrants are approved: Mueller Super Centurion and AVK Series 27 Nostalgic Style.

2. All fire hydrants shall be of the three-way style consisting of two (2) opposing hose nozzles separated by one (1) pumper nozzle, dry barrel type.
3. A clearly visible arrow and the word "OPEN" shall be cast in relief on the top of the fire hydrant. The fire hydrant shall be opened by turning the operating nut in a counter-clockwise direction.
4. The operating nut shall be all bronze, one piece, pentagon measuring 1¼" from point to flat and at least 1¼" in height.
5. The manufacturer's name, size of main valve and year of manufacture shall be cast in relief on the upper barrel section and clearly visible to aid in the identification of repair parts.
6. Lower barrel shall have ground line markings cast in relief and clearly visible approximately two-inches (2") below the flange to aid in proper installation.
7. The fire hydrant shall be a "traffic model" with the upper and lower barrels joined at approximately two-inches (2") above ground line by a separate and breakable swivel flange providing for 360 degree rotation of upper barrel for proper nozzle facing. The "traffic model" safety flange shall employ unweakened stainless steel hex head bolts (AWWA C502, Sec. 3.2.17) and fasteners of sufficient strength to bear all test and operating pressures. The stem shall be two-piece, not less than 1¼" in diameter (excluding threading or machined areas) and shall be connected by a breakable stem coupling. The weakened portion of the coupling shall be below the coupling pins to eliminate failure due to excessive torque. All screws, pins, bolts or fasteners used in conjunction with the coupling shall be stainless steel. The coupling shall be made of stainless steel to eliminate failure due to electrolysis and corrosion. The coupling joint shall be located below the top of the lower barrel to prevent vehicle wheel or other forces being applied to stem, which would open the valve mechanism.
8. Shoe and barrel castings shall be fabricated of ASTM A-126, Class B gray iron or ductile iron ASTM A-536, but no combination thereof, assuring uniform strength of all cast components.

B. Site Requirements

1. Fire Hydrants shall be placed at a maximum spacing of three-hundred feet (300') along all streets and fire lanes.
2. Fire hydrant leads shall have a bury depth of between four feet (4') and five feet (5').
3. Valves shall be placed on all fire hydrant leads. It shall be a mechanical joint and flanged tee with a flanged end to mechanical joint gate valve so that the valve is anchored to the main. All mechanical joints shall use restraining glands.
4. Fire hydrants shall be installed so the breakaway point will be no less than two inches (2") and no greater than six inches (6") above the final grade elevation.
5. Fire hydrants shall be located a minimum of three feet (3') and a maximum of six feet (6') from the fire lane or roadway, based on the location of the sidewalk. The fire hydrant should generally not be located in the sidewalk. When possible, the fire hydrant should be kept at least eighteen inches (18") from any sidewalks.
6. All fire hydrants placed on private property shall be adequately protected as approved by the Public Works Department and the Fire Department and shall be in easements. All such

protection shall be the responsibility of the landowner on which the said fire hydrant is placed.

7. All fire hydrants shall be installed so that the steamer connection will face the fire lane or street or as directed by the Fire Department and/or the Public Works Department.
8. A three foot (3') wide non-erodible surface shall be placed around the fire hydrant and from the fire hydrant to the curb directly in front of the pumper nozzle.
9. Fire hydrants shall be located at street or fire lane intersections, when feasible. When placed at intersections or access drives to parking lots, fire hydrants shall be placed so that no part of the fire truck will block the intersection or parking lot access when connections to the fire hydrant are made.
10. Fire hydrants required by this article and located on private property shall be accessible to the Fire Department at all times.
11. A Blue Stimsonite, Fire-Lite reflector model 88-SSA (or approved other) shall be placed just off center of the street or fire lane opposite fire hydrants. At intersections, reflectors shall be placed on both roadways opposite fire hydrant.
12. In non-residential developments an eight-inch (8") lead will be required on all fire hydrants that are located more than one hundred feet (100') from the looped main.
13. The fire hydrant shall be set on the projection of the property line when possible.
14. Fire hydrants shall not be installed within nine feet (9') vertically or horizontally of any wastewater main, wastewater lateral, or wastewater service line regardless of construction.

C. Operation

1. Hose nozzles shall be 2½", pumper nozzle shall be four-inch (4") pumper gauge (40480). Chains between the fire hydrant and nozzle caps shall be omitted. Nozzle section shall allow for field replacement of damage threads without special tools, excavation or disturbing the ground joint line. Nozzles shall be fastened by mechanical means and secured to prevent nozzles from turning or backing out. Nozzle caps shall be provided with 1¼" pentagon nuts at least 1¼" in height, a recess provided at the inner end of thread for gasket retention. Centerline of lowest nozzle shall be at least eighteen-inches (18") above ground line.
2. Main valve closure shall be compression type, opening against line pressure and closing with the pressure. Main valve shall be 5¼" in diameter. A bronze seat ring shall thread into a bronze drain ring (or shoe bushing). This bronze shall be low-zinc (less than 16%) to minimize galvanic corrosion. Design shall allow for removal of seat, drain valve mechanism, internal rod and all working parts through the top of the hydrant without disturbing the ground line joint or the nozzle section of the hydrant.
3. Lubrication of the upper stem threads, operating nut threads, and upper and lower thrust collar bearing surfaces and O-ring stem seals shall be done automatically as the hydrant is opened. Lubricant shall be low viscosity, non-toxic, FDA approved oil. Oil reservoirs shall be separated from the waterway by two (2) O-rings.
4. The drain system shall consist of two (2) valves feeding two (2) external discharges. Drain system shall be so designed as to provide for both automatic and intentional force flushing at full line pressure. Drain valve mechanism and outlet shall be all bronze.

5. The interior surfaces of the shoe and lower main valve components shall be epoxy coated in compliance with AWWA Standard C-550. The shoe and lower barrel shall be connected by stainless steel bolts, nuts and fasteners of sufficient size and strength to bear all pressures and forces that the hydrant is subject to, including corrosion, for its warranted life.

D. Painting and Delivery

1. Hydrants shall be delivered with two (2) coats of primer on upper barrel (AWWA C-502 Sec. 4.2.3). Interior and exterior shall be painted as in AWWA C-502 Sec. 4, excluding the interior of shoe which shall be painted be as noted in Sec. 2.F.
2. Hydrants shall be complete in all details when supplied. Due and customary care shall be used in preparation for shipment to eliminate damage in handling or transit. Hydrants must be drained and completely closed before shipment.
3. Manufacturer shall supply an Affidavit of Compliance verifying that the hydrant and all materials used in its construction conform to the applicable requirements of the most current form of AWWA C502 and these supplementary specification, that all specified tests have been performed and that all test requirements have been met.

X. WATER SERVICES:

The service curb stop shall be installed at a depth of eight-inches (8") to twelve inches (12") below finished grade, usually in advance of paving. After paving, the contractor shall furnish and install the meter box. The meter box is to be set within the right of way or utility easement line at or near the center of the front of the lot to be served. No meter box shall be installed in an area paved for vehicular traffic and/or parking spaces. Minimum requirements for water services:

A. General Design

1. All Meters shall meet or exceed the American Water Works Association Standard C707-R92 for Encoder-Type Remote-Registration systems for Cold Water Meters when equipped with an open architecture radio MIU.
2. Allowable tap and meter sizes are as follows: $\frac{3}{4}$ ", 1", 1½", 2", 4", 6", 8", 10" and 12". All other sizes are prohibited unless specifically approved by the Public Works Department. Taps and meters shall be the same size unless specifically waived by the Public Works Department.
3. Water meter boxes shall be provided for each service as per the Town of Addison Standard Details. Water meter boxes for meters two inches (2") and smaller shall have a minimum depth of eighteen inches (18") and have four inches (4") to six inches (6") of grade 4 crushed stone and four inches (4") to six inches (6") of free airspace placed under the meter inside the box. Meter boxes and openings shall be large enough to allow access to and operation of all meter nuts/flanges/bolts and the curb stop without obstruction. Meters larger than two inches (2") are required to be in a concrete vault. Openings below the finished grade in the meter box shall be permanently closed.
4. The size of services for apartments, condominiums, or multi-family services will depend on the number of units served with a minimum of one (1) meter per building.
5. All service taps on existing water mains shall be inspected and approved by the Public Works Department.
6. Multiple meters manifold in parallel are not permitted. In such instances a single larger meter

shall be selected.

7. Bullhead connections are not permitted unless approved by the Public Works Department.
8. Domestic and fire service connections on fire hydrant leads or dead end mains shall not be permitted.
9. Meters shall be set horizontally level in all directions.
10. All irrigation meters, fire meters and meters four inches (4") or larger in size shall be turbine meters. All domestic meters two inches (2") or smaller in size shall be positive displacement meters, unless otherwise approved by the Public Works Department.

B. Water Services two inches (2") and smaller shall include the following design criteria:

1. The service saddle shall be of one of the following:
 - a. Double-strap bronze with CC. (AWWA taper) threads: Mueller #BR2B, Ford #202B or McDonald #3825. Tap shall be set at 45° of vertical on the main line.
 - b. Mueller Servi-Seal™ style 502, 504, 506 or 508; seven inch (7") minimum length.
 - c. Ford Style FS303-CC.
2. Corporation stop with AWWA taper threads (CC) by conductive compression connection. Following is a list of approved corporation stops:
 - a. For ¾" use Mueller H-15008, Ford F1000-G or McDonald 4701BT.
 - b. For 1" use Mueller H-15008, Ford F1000-G or McDonald 4701BT.
 - c. For 1½" use Mueller H-15013, Ford FB1000-G or McDonald 4701T.
 - d. For 2" use Mueller B25008, Ford FB1000-G or McDonald 4701T.
3. 90° angle curb stop with lock-wing. Following is a list of approved curb stops:
 - a. For ¾" and 1" use Mueller H-14258 or B24258, Ford KV43-332W-G or KV43-444W-G and McDonald 4646BT or 4606BT.
 - b. For 1½" and 2" use Mueller H-14277, Ford FV43-666W-G or FV43-777W-G and McDonald 4646BT or 4606BT.
4. All companion flanges shall be elliptical brass and all bolts & nuts shall be grade 316 stainless steel, 5/8-11 x 2½" hex head.
5. The tapping saddle and corporation stop must be poly-wrapped (8 mil) and hand backfilled with sand to a depth of twelve inches (12"). Additional backfill may be placed by mechanical equipment and may consist of material free of rocks and clods exceeding three inches (3") in diameter. The Public Works Department shall inspect the installation of the polywrap and initial backfill.
6. Piping shall be type "K" copper, continuous from the corporation to the curb stop and completely embedded in sand for a distance of six inches (6") in all directions.

7. In-line curb-stops, meter yokes/setters, and/or meter risers are not permitted unless approved by the Public Works Department.
8. Gate valves on the inlet side of the meter are strictly prohibited.

XI. WATER METERS

All meters with top and bottom plates shall be made of bronze and equipped with electronic absolute encoded registers, programmed to read in thousand gallon increments, and equipped with touch-pad readers.

A. Domestic (potable) Use:

1. All 1.5" and smaller devices with flow capabilities ≤ 160 g.p.m. shall employ a nutating disc. Disc meters shall be Hersey 400 Series IIS™ or 500 Series IIS™, Sensus SR11, or Neptune T10.
2. All 2" and larger commercial unit applications for domestic use having flow demands greater than 160 g.p.m. shall employ a Hersey MVR™ turbine meter.

B. Irrigation services of any size shall employ a Hersey MVR™ turbine meter.

C. Fire Service:

1. Less than or equal to 2" meters shall be a Hersey MVR™ turbine meter.
2. Greater than 2" shall be either a Double Check Detector Assembly, or a Reduced Pressure Zone Detector Assembly. These assemblies shall be approved by the University of Southern California Foundation for Cross Connection Control and Hydraulic Research (USC-FCCCHR), and installed in USC approved orientations and clearances. The bypass or detector shall meet the requirement of the 1.5" or smaller domestic use written above.

XII. WATER EASEMENTS:

The following minimum width exclusive water easements are required when facilities are not located within public rights-of-way or easements:

- A. Water mains eight inches (8") or larger in diameter shall be located within the center of a minimum fifteen-foot (15') water easement. Fire lines smaller than eight inches (8") in diameter shall be located within the center of a minimum ten-foot (10') water easement.
- B. In residential developments, water mains shall not cross residential lots unless specifically approved by the Public Works Department, in which case the easement shall be located within a single lot.
- C. Fire hydrants located outside of public rights-of-way shall be centered in a ten-foot by ten-foot (10' x 10') water easement.
- D. Two-inch (2") and smaller meters serving multi-family residential and non-residential developments shall be set in a minimum five-foot by five-foot (5' x 5') water easement or in the right-of-way.
- E. Meters larger than two inches (2") shall be in a minimum ten-foot by ten-foot (10' x 10') water easement if not located within the public right-of-way.

WASTEWATER SYSTEM REQUIREMENTS

WASTEWATER SYSTEM REQUIREMENTS

I. GENERAL:

- A. Design criteria for all wastewater systems shall comply with Texas Commission on Environmental Quality (TCEQ) Chapter 217 (Design Criteria for Domestic Wastewater Systems), latest revision.
- B. Sizes and grades for wastewater mains shall be as required by the Town Engineer, and consideration shall be given as to possible extensions for future development. No wastewater main, other than laterals and force mains, shall be less than eight-inch (8") in diameter.
- C. Permits from agencies other than the town must be submitted through the town.
- D. All grades shall be shown to the nearest one-hundredth of a foot (0.01').
- E. Where applicable, line sizes shall comply with the Wastewater Collection System Master Plan or subsequent revisions.
- F. Wastewater mains shall be sized and extended through the limits of a development to serve adjacent properties. In phased construction of thoroughfares, the wastewater mains shall be extended the entire length of the thoroughfare being constructed.
- G. Finished floors shall be set a minimum of one half foot (0.5') above the upstream manhole.

II. WASTEWATER MAIN LOCATION:

- A. Wastewater mains in right of way shall be installed in the street at five feet (5') from the face of curb opposite side of the water main or otherwise directed by the Public Works Department. Wastewater mains are usually located in the center of the street. Each project is unique; therefore, no fixed rules will apply to all cases.
- B. No public wastewater main shall be located at least five feet (5') from any tree unless approved by the Public Works Department.
- C. Where a new non-pressure rated wastewater main or lateral crosses under a new water main, the wastewater main or lateral shall be embedded in cement stabilized sand for the total length of one pipe segment plus twelve inches (12") beyond the joint on each end and there shall be a minimum of twenty-four inches (24") of clearance or otherwise as governed by TCEQ Chapter 217 requirements.

III. WASTEWATER MAIN MATERIALS:

The material used for the wastewater main shall be designed for a minimum structural life cycle, of fifty (50) years. If the pipe material will deteriorate when subjected to corrosive conditions, the Engineer shall provide, for an acceptable corrosion resistant liner or provide calculation and data that demonstrated that the design and operational characteristics will provide for the minimum life cycle.

- A. All gravity wastewater mains shall be in green in color. Four-inch (4") to fifteen-inch (15") pipe shall be PVC SDR 35 or 26 (ASTM D3034). Eighteen-inch (18") and larger pipe shall be PVC ASTM F679. PVC fittings may be either green or white in color.
- B. All mains to be installed under existing roadway should be installed by bore unless otherwise approved by the Town Engineer. Rust resistant steel casing minimum one-fourth-inch (1/4") thick, or thicker if deemed necessary by the design engineer, shall be used with Raci patented casing

spacers, or approved equal. No wood skids will be permitted.

- C. PVC pipe used for force mains shall be white in color. Twelve-inch (12") and smaller pipe shall be ASTM 2241 SDR 21. Pipes larger than twelve-inch (12") shall be C905 DR25.
- D. Profile wall pipe shall not be permitted in the Town of Addison without written authorization by the Town Engineer. If allowed by the Town Engineer, twenty-four inches (24") and larger profile wall pipe shall conform to ASTM 794 and the Town of Addison specifications. "Helically wound" or "pipe stiffness series 10" profile wall pipe will not be allowed.
- E. Cement stabilized sand shall have a minimum of ten percent (10%) cement per cubic yard of cement stabilized sand mixture, based on loose dry weight volume (at least 2.5 bags of cement per cubic yard of mixture). The cement stabilized sand bedding shall be a minimum of six inches (6") above and four inches (4") below the wastewater main or lateral. Brown coloring shall be added to the cement stabilized sand mixture for pressure rated wastewater main or lateral bedding.

IV. WASTEWATER MAIN SIZING:

- A. Wastewater flow shall be computed in accordance with Tables 1a and 1b shown below, with the exceptions, as required by the Town Engineer.

Table 1a: Residential Design Flows

Land Use	Design Flow Rate
Single Family	<ul style="list-style-type: none"> • 100 gallons per person per day • 4.5 units per acre • 3 persons per unit
Apartment	<ul style="list-style-type: none"> • 100 gallons per person per day • 20 units per acre • 3 persons per unit
Patio Home	<ul style="list-style-type: none"> • 100 gallons per person per day • 5 units per acre • 3.5 persons per unit
Town Home	<ul style="list-style-type: none"> • 100 gallons per person per day • 10 units per acre • 3.5 persons per unit

Table 1b: Commercial Design Flows

Land Use	Design Flow Rate
Hospital	• 200 gallons per day per bed
Nursing Home	• 90 gallons per day per bed
Office/Commercial	• 0.1 gallons per sf per day
Restaurant	• 1 gallon per sf per day
School	• 15 gallons per student per day
Hotel/Motel	• 150 gallons per day per room
Medical Office	• 0.2 gallons per sf per day

Note: Infiltration shall be 650 gallons per acre per day (GPAD). For eight-inch (8"), ten-inch (10"), and twelve-inch (12"), the daily peak factor shall be 3, for fifteen-inch (15"), eighteen-inch (18"), and twenty-one-inch (21"), the daily peak factor shall be 2 and for twenty-four-inch (24") and larger, the daily peak factor shall be 1.

Calculation: Design flow rate*units*peak factor + infiltration rate*area = Peak Wet Weather Flow

Example Residential Calculation: 56 acres of single family residential
 $(100*4.5*3)*56 \text{ acres} * 3 + 650*56 = 263,200 \text{ gallons per day}$

Example Commercial Calculation: 10,000 sf retail store on 1 acre lot
 $0.1*10,000*3 + 650*1 = 3,650 \text{ gallons per day}$

- B. The minimum acceptable "n" factor for use in design of wastewater mains shall be 0.013. Mains should be placed on such a grade that the velocity is not less than 2 fps or more than 10 fps. Minimum grades based on n = 0.013 shall be as follows:

TABLE 2: Minimum and Maximum Grades for Wastewater Mains

Size of Pipe (Inches)	Minimum Slope in (Percent)	Horizontal Curve (Percent)	Maximum Slope in (Percent)
8	0.33	0.35	8.40
10	0.25	0.27	6.23
12	0.20	0.22	4.88
15	0.15	0.17	3.62
18	0.11	0.13	2.83
21	0.09	0.10	2.30
24	0.08	0.09	1.93
27	0.06	0.07	1.65
30	0.055	0.065	1.43
33	0.05	0.06	1.26
36	0.045	0.055	1.12
39	0.04	0.05	1.01
>39	*		*

Note: For lines larger than thirty-nine inches (39") in diameter, the slope shall be determined using the following equation to maintain a minimum velocity of two feet per second (2 fps) and a maximum velocity of ten feet per second (10 fps).

$$V = (1.486/n) \cdot (R^{2/3}) \cdot (S^{1/2})$$

- Where:
- V = Velocity of flow in conduit in feet per second.
 - n = Roughness coefficient of the conduit, dimensionless.
 - R = Hydraulic radius of the conduit in feet, which is the area of the flow divided by the wetted perimeter (R=A/P).
 - S = Slope of the hydraulic gradient in feet per foot.

V. WASTEWATER CONSTRUCTION:

- A. Line and grade stakes for construction of all mains and laterals shall be furnished by the developer's Engineer or their designated representative. Property lines and corners must be properly staked to ensure correct alignment. The town will not be liable for improper alignment or delay of any kind caused by improper or inadequate surveys by the developer or by interference of other utilities.
- B. All wastewater mains shall be tested for infiltration and exfiltration in accordance with standard specifications and as shown on the plans. Video camera inspections, low pressure air testing, vacuum testing of the manholes and mandrel testing are required on all sewer lines. In addition, all residential and commercial wastewater services shall have video camera inspections. All video camera inspections shall include an inclination study. All testing shall be completed, reviewed and approved by the Town of Addison prior to any final inspections or issue of certificate of occupancy.

VI. TRENCH REQUIREMENTS:

- A. Minimum cover shall be four feet (4'). In general, the minimum depth for wastewater mains to serve given residential property with a four-inch (4") lateral shall be three feet (3') plus 2% times the length of the house lateral (the distance from the sewer to the center of the house). Thus, for a house one hundred thirty-five feet (135') from the sewer, the depth would be three feet (3') plus 2% x one hundred thirty-five feet (135') = 3.0 + 2.7 = five and seven-tenths feet (5.7'). The depth of the flow line of the sewer should then be at least five and seven-tenths feet (5.7') below the elevation of the ground at the point where the service enters the house. Profiles of the ground line twenty feet (20') past the building line will be required to verify that this criterion is met.

VII. MANHOLES:

The sizes and locations of manholes, wyes, bends, tap connections, etc., shall be approved by the Town Engineer. In general, manholes shall be placed at all four (4) way connections and three (3) way connections, changes in grade and direction, and the maximum spacing five hundred feet (500').

- A. In order to provide access to wastewater mains for cleaning, manholes shall be located such that two hundred fifty feet (250') of rod can reach any point in the line. Manholes shall be located at the end of the line or on a line that may be extended in the future.
- B. Manholes shall have a 400lbs traffic bearing frame and cover with a design strength of 4000 psi at twenty-eight (28) days.
- C. Drop manholes shall be required when the inflow elevation is more than twenty-four inches (24") above the outflow elevation.
- D. The diameter of a manhole constructed over the center of a wastewater main should vary with the size of the main. For eight-inch (8"), ten-inch (10"), and twelve-inch (12"), the manhole shall be four-foot (4') minimum diameter, for fifteen-inch (15"), eighteen-inch (18"), twenty-one-inch (21"), twenty-four-inch (24") and twenty-seven-inch (27") shall be five-foot (5') minimum diameter; thirty-inch (30") and thirty-six-inch (36") shall be six-foot (6') minimum diameter. Manholes deeper than fifteen feet (15') shall be a minimum of five-foot (5') diameter.
- E. In Flood Plains, sealed manholes "Type S" shall be used to prevent the entrance of storm water. Coating in manhole where more than three manholes in sequence are to be bolted and gasketed, every third manhole shall be vented two feet (2') above the one hundred (100) year floodplain elevation or ten feet (10') above the adjacent ground line, whichever is higher. The Engineer shall provide the elevation of the one hundred (100) year flood. Sealed manholes shall also be used in all areas subject to carrying drainage flow or in drainage ways.
- F. Where pipes enter a manhole there shall be a minimum of one-tenth of a foot (0.1') drop between inlet and outlet inverts. Where unequal size pipes enter a manhole, crown of pipes should be at the same elevation.
- G. Manholes shall have inflow protection inserts, minimum thickness of one-eighth inch (1/8"), made of HDPE meeting ASTM D 1248 Class A, Category 5, Type 111. Insert shall include a lift strap as manufactured by Knutson Manhole Inserts or approved other.
- H. Construct manholes at each end of mains that are installed by other than open cut and at each end of aerial crossing lines.
- I. Manhole vent stacks shall be placed on all manholes within 1000 feet of an outfall from a force main.

VIII. WASTEWATER MAIN CURVATURE:

- B. No vertical curves shall be allowed.
- C. Horizontal curvature may be by joint deflection or pipe flexure but not both. The Engineer must specify on the plans the method of deflection allowed and the allowable radius or joint deflection for each pipe size.
- D. When pipe flexure is used, the minimum radius of curvature shall be equal to that recommended by the pipe manufacturer or $300 \cdot D_o$, where D_o is the average outside diameter of the pipe in inches,

which ever is greater. The Engineer shall note on the plans that, when using pipe flexure, all joints are to remain fully seated.

- E. If joint deflection will be used to provide horizontal curvature, the allowable deflection shall be 80% of the Manufacturer's recommended maximum joint deflection, or eighty percent (80%) of the National Reference Standard ASTM criteria maximum recommended joint deflection or by TCEQ Criteria, whichever is less. In no case shall the radius be less than two hundred feet (200').
- F. Horizontal curves for wastewater mains running parallel with public right-of-ways shall match change in street direction as near as possible. Horizontal curves will not be allowed across residential single family and duplex lots, without prior approval from the Town Engineer.
- G. Manholes on curved wastewater mains shall be located at the P.C. or P.T. of the curve and a maximum spacing of four hundred feet (400') along the curve.

IX. LATERALS:

The sizes and locations of laterals shall be designated as follows unless otherwise directed by the Town Engineer:

- A. In general, for single-family dwellings, the lateral size shall be a four-inch (4") minimum. House laterals shall be installed ten feet (10') downstream from the center of the lot and shall have a ten-foot (10') separation from the water service. All residential sewer services shall be extended to a point ten feet (10') from the back of the property line at a maximum depth of five feet (5'). The service shall then be extended at a forty-five degree (45°) angle to four feet (4') above the finished grade and capped.
- B. Multiple units, apartments, local retail and commercial – six-inch (6") minimum.
- C. Manufacturing and industrial - eight-inch (8") minimum or larger as required.
- D. Manholes will be required on six-inch (6") and larger laterals where they connect to the main line.
- E. Manholes will be required where wastewater laterals intersect wastewater mains that are deeper than twelve feet (12'). Deep cut or drop connections shall not be permitted.
- F. A double cleanout shall be installed on the lateral at the right-of-way or easement line. Fittings are not permitted on laterals between the wye and the double cleanout.
- G. A minimum of one (1) lateral per building shall be required. Also, a minimum of one (1) lateral per residential lot shall be required. Shared laterals are not permitted unless otherwise approved by the Public Works Department.
- H. All mains installed in future developed areas shall install laterals; the use of boots will not be permitted.
- I. All sewer laterals crossing water mains shall conform to the requirements of the Texas Commission on Environmental Quality (TCEQ) Chapter 217 (Design Criteria for Domestic Wastewater Systems), latest revision.

X. SANITARY SEWER EASEMENTS:

The following minimum width exclusive wastewater easements are required when facilities are not

located within public rights-of-way or easements:

- A. Wastewater mains are to be located within the center of a fifteen-foot (15') wastewater easement.
- B. In residential developments, wastewater mains shall not cross residential lots unless specifically approved by the Town Engineer, in which case the easement shall be located within a single lot.
- C. For wastewater mains deeper than ten feet (10'), the easement width shall be equal to 1.5 times the depth of the line rounded up to the nearest five feet (5'). Thus, for a sanitary sewer line twelve feet (12') deep, the sanitary sewer easement would be $1.5 \times \text{twelve feet (12')} = 1.5 \times 12 = \text{eighteen feet (18')}$, rounded up to the nearest five feet (5') = twenty feet (20').

TRAFFIC SIGNAL REQUIREMENTS

The CONTRACTOR shall notify of the Town of Addison at least one week prior to starting work on this project.

The CONTRACTOR will only be allowed to work on this project during daylight hours (8 am to 5 pm Monday - Friday). Lane closures will only be allowed between the hours of 9 am and 3 pm Monday - Friday.

The CONTRACTOR shall clean up and remove from work area all loose material resulting from the contract operations each day before work is suspended. Any obstructions to existing drainage due to the CONTRACTOR's operations will be removed by the CONTRACTOR as required by the Town at the CONTRACTOR's entire expense.

THE TRAFFIC SIGNAL INSTALLATION CONSISTS OF THE FOLLOWING PRINCIPLE ITEMS:

1. Furnish and install controller cabinet assembly according to Town specifications, or relocate existing signal controller cabinet assembly as indicated in plans.
2. Remove and salvage existing traffic signal assemblies.
3. Furnishing and installing signal pole/mast arm assemblies, signal heads, and signal cable.
4. Furnishing and installing conduit, ground boxes.
5. Furnishing and installing VIVDS detection system and signal preemption detectors.
6. Furnishing and placing all concrete and reinforcing steel for the signal pole foundations, and controller foundation.
7. The CONTRACTOR shall also furnish and install all other items not listed above which are needed to provide the complete traffic signal installation as called for in the plans and specifications.

SIGNAL TECHNICIAN

A signal technician from the Town of Addison shall be present when the signals are placed in operation. The CONTRACTOR shall notify Brandon Graham at (972) 450-2871 a minimum of 48 hours in advance of the turn on.

SIGNAL START UP AND TEST PERIOD FOR SIGNALS

Unless directed by the Town, the signal shall be placed in flashing mode on a Tuesday, Wednesday, or Thursday only between 9:00 am and 12:00 pm. Unless directed by the Town, the signal shall be placed in full operation between 9:00 am and 12:00 pm (noon) on a Monday, Tuesday, or Wednesday only. Once the signals have been installed and placed in operation, they shall operate continuously for a minimum of 30 calendar days in a satisfactory manner. Equipment failures during these 30 days will cause the test period to start over.

WIRING AND SIGNAL OPERATIONS

The CONTRACTOR shall be responsible for terminating all field wiring inside the cabinet. Wiring inside the cabinet shall be performed by the CONTRACTOR according to instructions from the Town of Addison and according to the cable termination chart.

EXISTING UTILITIES

The exact location of the underground utilities is not certain. The CONTRACTOR shall contact the Town of Addison and utility companies with utilities in the area for the exact location prior to drilling for foundations and any other work that might interfere with or damage present utilities. Known utilities include town water and sewer lines, TXU electric lines, SBC telecommunication lines, TXU gas lines, and fiber optic lines. Location of some of these utilities can be determined by calling the number 1-800-DIG-TESS. No additional payment will be made for relocation of foundations due to utilities.

Texas state law, article 1436c, makes unlawful the operation of equipment or machines within 10 feet of any overhead electrical line unless danger against contact with high voltage lines has been effectively guarded against pursuant to the provisions in the article. When construction operations requires working near an overhead electrical line, the CONTRACTOR shall contact the owner operator of the overhead electrical line to make adequate arrangements and to take the necessary safety precautions to ensure that all laws, electrical line owner/operator requirements, and standard industry safety practices are met.

ELECTRICAL CONDUCTORS

All electrical conductors for breakaway poles shall be breakaway (Buchanan 65u, Bussman hebw, Littlefuse leb, or equal) in accordance with RID(2). All electrical connections for neutrals shall be breakaway, shall have a white color marking, and shall permanently installed solid neutral (Buchanan 20u, Bussman het, Littlefuse let, or equal). Grounding conductors that share the same conduit, ground box, or structure shall be bonded together at every accessible point in accordance with the NEC.

CONDUIT

Underground conduit for cable shall be schedule 40 PVC. All couplings and connections shall be tight and waterproof. PVC conduit shall be heavy-wall schedule 40, unless otherwise approved by the engineer. All conduit elbows and rigid metal extensions required to be installed on PVC conduit systems will not be paid separately, but will be considered subsidiary to various bid items.

Conduit to be placed under existing pavement shall be placed at a minimum depth of 3 feet below the pavement surface. If it is determined by the engineer that it is impractical to place conduit by jacking or boring, the open trench method may be used, when approved, at no additional expense to the owner. In the event that the open trench method is used, the trench shall be backfilled to a condition acceptable to the Town engineer.

POLE ASSEMBLIES, POLE FOUNDATIONS AND ANCHORS

Critical pole assembly features and dimensions required for this project are shown on the plan detail sheets. Pole shaft/mast arm identification numbers shall be stenciled on pole shafts and mast arms before shipment to insure matching of poles and mast arms during field assembly. Signal pole assemblies shall be powder coated SILVER.

No mast arm poles shall be placed on the foundations prior to seven (7) days following placement of concrete. The dimensions shown on the plans for location of foundations, conduit and other items may be varied to meet local conditions, subject to approval by the Town of Addison.

The CONTRACTOR shall notify Brandon Graham at (972) 450-2871 at least 48 hours before placing concrete. Cylinders will be made for testing by a laboratory approved by Town personnel.

TRAFFIC SIGNAL CONTROLLER AND CABINET ASSEMBLY

If called for on plans, the CONTRACTOR shall furnish and install an Econolite asc/3-1000 ts2 traffic signal controller and cabinet assembly. This equipment shall be in accordance with town of Addison Special Specification A9004. CONTRACTOR shall be paid according to installation of highway traffic signals.

SIGNAL HEADS

Unless otherwise shown in the plans, all signals shall be mounted vertically. All signal heads shall be covered with burlap or other approved material from the time of installation until the signal is placed in operation. LED signal lamps shall be used for all signal indications and furnished and installed by the CONTRACTOR. All signal heads shall be polycarbonate with polycarbonate back-plates. Pedestrian signal heads shall be aluminum.

GROUND BOXES

CONTRACTOR shall install a 5/8" x 8' copper clad ground rod in a ground box nearest to each signal pole. A ground wire (#8 bare) shall be installed from this ground rod to the base of the pole. Each ground rod shall be electrically bonded to all other ground rods on this premise. The ground wire (#8 bare) shall bond all ground rods back to the electrical service. The cost of the ground rod shall be considered subsidiary to this item.

SIGNING

All new signs shall be furnished and installed by the CONTRACTOR. All new sign sheeting shall be High Intensity Prismatic (HIP). The CONTRACTOR shall verify the specifications and all information to be placed on the Illuminated Street Name Signs ((ILSNs) with the Town of Addison prior to fabrication. The CONTRACTOR shall contact Ms. Nancy Cline at (972) 450-2871 to obtain this information.

SIGNAL PREEMPTION DETECTORS

The CONTRACTOR shall furnish and install an opticom detector system manufactured by Global Traffic Technologies. The CONTRACTOR shall furnish four (4) Type 721 uni-directional opticom detectors, two (2) Type 752 2-channel phase selectors, and opticom detector cable.

WIRING

Extra cable length shall be included in each run to provide adequate slack, as determined by the Town inspector, at each ground box or foundation. No splicing shall be allowed in signal preemption or VIVDS detector cables. No splicing shall be allowed in the traffic signal cable except at pole base.

PAVEMENT MARKINGS

Pavement markings to be installed by others as part of roadway construction project.

VIDEO IMAGING VEHICLE DETECTION SYSTEM (VIVDS)

Contractor is to relocate existing detection equipment to new signal mast arms. The CONTRACTOR will not be required to supply a computer for VIVDS set-up. If a computer is required for set-up, the CONTRACTOR shall supply and use his/her own computer.

WIRELESS COMMUNICATION

The CONTRACTOR shall furnish and install a Wireless Ethernet Radio Subscriber Unit and CAT 5E Ethernet Cable. This equipment shall be in accordance with the Town of Addison Special Specification A9007.

The CONTRACTOR shall furnish and install a Hardened Ethernet Switch inside the controller cabinet. This equipment shall be in accordance with the Town of Addison Special Specification A9001.

The CONTRACTOR shall furnish and install a Video Server inside the controller cabinet. This equipment shall be in accordance with the Town of Addison Special Specification A9002.

CONTRACTOR'S RESPONSIBILITY FOR THE WORK

The CONTRACTOR shall be responsible for all installations until accepted by the Town as required by the general provisions and requirements. Should "knock downs" occur, the CONTRACTOR shall be responsible for all labor to reinstall said equipment at no additional cost to the Town. If new equipment is required, as determined by the Town, the CONTRACTOR shall provide replacement equipment at no additional cost to the Town.

HANDLING OF TRAFFIC

Roads and streets shall be kept open to traffic at all times. The CONTRACTOR shall, unless otherwise directed by the Town, arrange the work in the roadway so as to close only one lane of the roadway at a time. All construction operations shall be conducted to provide the least possible interference to traffic as provided in the specifications and/or as directed by the Town.

The CONTRACTOR shall arrange the installation of signals, poles, and conduit so as to permit the continuous movement of the traffic in both directions at all times. A pre-construction conference including Town staff shall outline intersection construction phases. A traffic control plan (TCP) for this project shall be as detailed on standard sheets WZ (BTS-1) - 03 and WZ (BTS-2) - 03. All construction signs shall be mounted on fixed supports (4" x 4" wood posts) unless otherwise directed by the Town.

SECTION IS

ADDITIONAL INSURANCE REQUIREMENTS

TOWN OF ADDISON, TEXAS
BELT LINE ROAD UNDERGROUND UTILITIES – PHASE 1

REQUIREMENTS

Contractors performing work on TOWN OF ADDISON property or public right-of-way shall provide the TOWN OF ADDISON a certificate of insurance or a copy of their insurance policy(s) (and including a copy of the endorsements necessary to meet the requirements and instructions contained herein) evidencing the coverages and coverage provisions identified herein within ten (10) days of request from TOWN OF ADDISON. Contractors shall provide TOWN OF ADDISON evidence that all subcontractors performing work on the project have the same types and amounts of coverages as required herein or that the subcontractors are included under the contractor's policy. Work shall not commence until insurance has been approved by TOWN OF ADDISON.

All insurance companies and coverages must be authorized by the Texas Department of Insurance to transact business in the State of Texas and must have a A.M. Best's rating A-:VII or greater.

Listed below are the types and minimum amounts of insurances required and which must be maintained during the term of the contract. TOWN OF ADDISON reserves the right to amend or require additional types and amounts of coverages or provisions depending on the nature of the work.

TYPE OF INSURANCE	AMOUNT OF INSURANCE	PROVISIONS
1. Workers' Compensation Employers' Liability to include: (a) each accident (b) Disease Policy Limits (c) Disease each employee	Statutory Limits per occurrence Each accident \$1,000,000 Disease Policy Limits \$1,000,000 Disease each employee \$1,000,000	TOWN OF ADDISON, and RH Shackelford, Inc. to be provided a <u>WAIVER OF SUBROGATION AND 30 DAY NOTICE OF CANCELLATION</u> or material change in coverage. Insurance company must be A-:VII rated or above.
2. Commercial General (Public) Liability to include coverage for: a) Bodily Injury b) Property damage c) Independent Contractors d) Personal Injury e) Contractual Liability	Bodily Injury/Property Damage per occurrence \$1,000,000, General Aggregate \$2,000,000 Products/Completed Aggregate \$2,000,000, Personal Advertising Injury per occurrence \$1,000,000, Medical Expense 5,000	TOWN OF ADDISON, and RH Shackelford, Inc. to be listed as <u>ADDITIONAL INSURED and provided 30 DAY NOTICE OF CANCELLATION</u> or material change in coverage. Insurance company must be A-:VII rated or above.
3. Business Auto Liability to include coverage for: a) Owned/Leased vehicles b) Non-owned vehicles c) Hired vehicles	Combined Single Limit \$1,000,000 per occurrence for bodily injury and property damage	TOWN OF ADDISON, and RH Shackelford, Inc. to be listed as <u>ADDITIONAL INSURED and provided 30 DAY NOTICE OF CANCELLATION</u> or material change in coverage. Insurance company must be A:VII-rated or above.
4. Umbrella or Excess Liability Policy over Commercial General Liability and Automobile Liability limits of \$1 million per occurrence	Minimum \$4 million per occurrence excess \$1 million underlying per occurrence	TOWN OF ADDISON, and RH Shackelford, Inc. to be listed as <u>ADDITIONAL INSURED and provided 30 DAY NOTICE OF CANCELLATION</u> or material change in coverage. Insurance company must be A:VII-rated or above.

Certificate of Liability Insurance forms (together with the endorsements necessary to meet the requirements and instructions contained herein) may be **faxed** to the Purchasing Department: **972-450-7074** or **emailed to: purchasing@addisontx.gov**. Questions regarding required insurance should be directed to the Purchasing Manager.

With respect to the foregoing insurance,

1. All liability policies shall contain no cross liability exclusions or insured versus insured restrictions applicable to the claims of the Town of Addison.
2. All insurance policies shall be endorsed to require the insurer to immediately notify the Town of Addison, Texas of any material change in the insurance coverage.
3. All insurance policies shall be endorsed to the effect that the Town of Addison, Texas will receive at least thirty (30) days' notice prior to cancellation or non-renewal of the insurance.
4. All insurance policies, which name the Town of Addison and RH Shackelford, Inc. as an additional insured, must be endorsed to read as primary coverage regardless of the application of other insurance.
5. Insurance must be purchased from insurers that are financially acceptable to the Town of Addison and licensed to do business in the State of Texas.

All insurance must be written on forms filed with and approved by the Texas Department of Insurance. Upon request, Contractor shall furnish the Town of Addison with complete copies of all insurance policies certified to be true and correct by the insurance carrier.

This form must be signed and returned with your quotation. You are stating that you do have the required insurance and if selected to perform work for TOWN OF ADDISON, will provide the certificates of insurance (and endorsements) with the above requirements to TOWN OF ADDISON within 10 working days.

A CONTRACT/PURCHASE ORDER WILL NOT BE ISSUED WITHOUT EVIDENCE AND APPROVAL OF INSURANCE.

AGREEMENT

I agree to provide the above described insurance coverages within 10 working days if selected to perform work for TOWN OF ADDISON. I also agree to require any subcontractor(s) to maintain insurance coverage equal to that required by the Contractor. It is the responsibility of the Contractor to assure compliance with this provision. The Town accepts no responsibility arising from the conduct, or lack of conduct, of the Subcontractor.

Project/Bid# _____

Company: _____

Printed Name: _____

Signature: _____ **Date:** _____

**GEOTECHNICAL INVESTIGATION
BELT LINE ROAD STREET IMPROVEMENT
FROM MIDWAY ROAD TO MARSH LANE
ADDISON, TEXAS**

SUBMITTED TO

**TOWN OF ADDISON
16801 WESTGROVE DRIVE
ADDISON, TX 75001**

**BY
HVJ ASSOCIATES, INC.
DALLAS, TEXAS.**

JANUARY 29, 2014

REPORT NO. DG-12-15641



Houston | 8701 John Carpenter Freeway, Suite 250
Austin | Dallas, Texas 75247-4640
Dallas | 214.678.0227 Ph
San Antonio | 214.678.0228 Fax
www.hvj.com

January 29, 2014

Ms. Lisa Piles
Director of Infrastructure & Operations Services
Town of Addison
16801 Westgrove Drive
Addison, TX 75001

Re: Geotechnical Investigation
Belt Line Road Street Improvement- From Midway Road to Marsh Lane
Owner: Town of Addison
HVJ Project No. DG1215641

Dear Ms. Piles:

Submitted herein is the report of our geotechnical investigation for the above referenced project. The study was conducted in general accordance with our proposal number DG-12-15641 dated July 02, 2013 (Revised September 27, 2013) and is subject to the limitations presented in this report.

We appreciate the opportunity of working with you on this project. Please read the entire report and notify us if there are questions concerning this report or if we may be of further assistance.

Sincerely,

HVJ ASSOCIATES, INC.
Texas Firm Registration No. F-000646

A handwritten signature in black ink that reads 'Park'.

Jae Hyun Park, PE
Project Manager



01/29/2014

A handwritten signature in black ink that reads 'Raviteja Elepe'.

Raviteja Elepe, EIT
Staff Engineer

JP/RE/SS/FF

The seal appearing on this document was authorized by Jae Hyun Park, PE 103692 on January 29, 2014. Alteration of a sealed document without proper notification to the responsible engineer is an offense under the Texas Engineering Practice Act.

The following lists the pages which complete this report:

- Main Text – 20 pages
- Plates – 29 pages
- Appendix A – 3 pages
- Appendix B – 12 pages
- Appendix C – 10 pages

CONTENTS

	<u>Page</u>
1 EXECUTIVE SUMMARY	I
2 INTRODUCTION	1
2.1 Project Description	1
2.2 Geotechnical Investigation Program	1
3 FIELD INVESTIGATION	1
3.1 Geotechnical Borings.....	1
3.2 Sampling Methods	1
3.3 Groundwater Observations	2
3.4 Borehole Completion	2
4 LABORATORY TESTING.....	2
4.1 Sample Examination and Classification Testing	2
4.2 Geotechnical Laboratory Testing	2
5 SITE CHARACTERIZATION	3
5.1 Site Location.....	3
5.2 General Geology.....	3
5.3 Soil Stratigraphy.....	3
6 UTILITY DESIGN CRITERIA AND RECOMMENDATIONS	4
6.1 General.....	4
6.2 Geotechnical Parameters	4
6.3 Pipe Installation recommendations	5
7 UTILITY CONSTRUCTION CONSIDERATIONS.....	8
7.1 General.....	8
7.2 Boring, Jacking, or Tunneling Construction Considerations.....	8
7.3 Open-Cut Excavation Considerations.....	10
7.4 Lateral Earth Pressures	10
7.5 Groundwater Control	11
8 MONITORING.....	12
8.1 Excavation Safety	12
8.2 Construction Materials Testing	12
9 PAVEMENT DESIGN RECOMMENDATIONS	12
9.1 General.....	12
9.2 Preparation of Subgrade	13
10 DESIGN REVIEW	14
11 LIMITATIONS.....	14

ILLUSTRATIONS

	<u>Plate</u>
SITE VICINITY MAP	1
GEOLOGY MAP	2
PLAN OF BORINGS	3A-3J
BORING LOGS.....	4-13
KEY TO TERMS & SYMBOLS USED ON BORING LOGS.....	14A & 14B
BRACED EXCAVATION LATERAL EARTH PRESSURE DIAGRAM	15
RIGID PIPE LOADS	16

APPENDIX

	<u>Appendix</u>
SUMMARY OF LABORATORY TEST RESULTS	A
PAVEMENT CORE PICTURES.....	B
SULFATE TEST RESULTS	C

1 EXECUTIVE SUMMARY

HVJ Associates, Inc. was retained by Town of Addison, Infrastructure & Operations Services to perform a geotechnical investigation for the proposed Belt Line Road Street improvements in Addison, Texas. The project involves utility cuts with select full-depth reconstruction and complete roadway surface HMAC treatment at Belt Line Road between Midway Road and Marsh Lane in Addison, Texas. The proposed utilities include a new concrete or steel cased duct bank and telecommunications duct banks at depth ranging from about 11 to 20 feet. Additionally there will be same smaller duct banks on both sides of the ROW for the entire length at depth ranging from about 5 to 8 feet. The purpose of this study is to provide design and construction recommendations for the proposed improvements.

Subsurface conditions were evaluated by drilling and sampling ten (10) borings (B-1 to B-10) to a depth of approximately 20 to 30 feet below the existing ground surface. Boring B-7 could not be drilled to termination depth due to conflict with utilities. A brief summary of the investigational findings are as follow:

1. Subsurface conditions encountered during our field activity in the borings are summarized in the following table.

Stratum Types Encountered

Stratum Type	Approximate Depths of Strata Encountered at Borings (ft)									
	B-1	B-2	B-3	B-4	B-5	B-6	B-7	B-8	B-9	B-10
Pavement +Base	0-1.2	0-1.2	0-1.2	0-1.2	0-1	0-1	0-1	0-1	0-1	0-1
Fill⁽¹⁾	1.2-9.5	1.2-12.5	1.2-6.5	1.2-4.5	1-2.5	1-3	1-4 ⁽⁶⁾	1-7	1-2	1-4.5
Shaley Clay (CH)⁽²⁾	9.5-16	12.5-20 ⁽⁶⁾	6.5-13	-	-	-	-	-	-	-
Shale⁽³⁾	16-20 ⁽⁶⁾	-	13-20 ⁽⁶⁾	-	-	-	-	-	-	-
Weathered Limestone⁽⁴⁾	-	-	-	4.5-7.5	2.5-8	3-8	-	7-13	2-8	4.5-11.5
Unweathered Limestone⁽⁵⁾	-	-	-	7.5-30 ⁽⁶⁾	8-20 ⁽⁶⁾	8-20 ⁽⁶⁾	-	13-20 ⁽⁶⁾	8-30 ⁽⁶⁾	11.5-20 ⁽⁶⁾

Note:

- (1) Fill; consists of sandy clay, clayey sand, fat clay and lean clay with gravels, calcareous deposits and weathered limestone.
 - (2) Very stiff to hard.
 - (3) Soft; occasional limestone seams.
 - (4) Soft to hard.
 - (5) Very hard.
 - (6) Boring termination depth.
2. Groundwater was not encountered in any borings during or after drilling operations. However, it should be noted that groundwater levels will fluctuate with seasonal changes in moisture conditions.
 3. The pavement surface was cored at twenty locations (B-1 to B-10 and C-1 to C-10). The core data reveals that the existing pavement is approximately 2 to 3 inches of asphalt,

followed by approximately 5.5 to 9 inches of concrete. Pictures of pavement cores are included in Appendix B.

4. A laboratory testing program, consisting of moisture contents, Atterberg limits, unconfined compression and minus 200 sieve analysis were performed on select soil samples. The testing results were summarized and included in Appendix A.
5. The Sulfate content tests were performed on borings B-2, B-6 and B-8 on the upper 4 feet sample. The test results are included in Appendix C.
6. A new steel cased duct bank and telecommunications duct banks will be installed at depth ranging from approximately 11 to 20 feet. Additionally there will be some smaller duct banks on both sides of the ROW for the entire length will be installed at depth of approximately 5 to 8 feet. We also assumed that all lines will be installed using open-cut and/or auguring techniques.

Please note that this executive summary does not fully relate our findings and opinions. Those findings and opinions are only presented through our full report.

2 INTRODUCTION

2.1 Project Description

HVJ Associates, Inc. was retained by Town of Addison, Infrastructure & Operations Services to perform a geotechnical investigation for the proposed Belt Line Road Street improvements in Addison, Texas. The project involves utility cuts with select full-depth reconstruction and complete roadway surface HMAC treatment at Belt Line Road between Midway Road and Marsh Lane in Addison, Texas. A site vicinity map is included in Plate 1.

2.2 Geotechnical Investigation Program

The primary objectives of this investigation were to gather information on subsurface conditions at the site and to provide design recommendations for the proposed utility reconstruction and pavement improvement. The objectives were accomplished by:

1. Drilling and coring twenty (20) locations (i.e. B-1 to B-10 and C-1 to C-10) to determine pavement type and thickness, soil stratigraphy and to obtain samples for laboratory testing;
2. Performing laboratory tests on the samples obtained from the borings in order to determine the essential physical and engineering characteristics of the soils; and
3. Performing engineering analyses to develop utility reconstruction and pavement design guidelines.

Subsequent sections of this report contain descriptions of the field exploration, laboratory-testing program, general subsurface conditions, utility and pavement design guidelines, and general earthwork recommendations.

3 FIELD INVESTIGATION

3.1 Geotechnical Borings

The field exploration program was undertaken at the project site between October 28, 2013 and October 31, 2013. The subsurface conditions were evaluated by drilling and sampling a total of ten (10) borings (B-1 to B-10) to depth of approximately 20 to 30 feet below existing ground surface. The pavement surface was cored at twenty locations (B-1 to B-10 and C-1 to C-10). The core data reveals that the existing pavement is approximately 2 to 3 inches of asphalt, followed by approximately 5.5 to 9 inches of concrete. A site plan showing the approximate boring locations is presented on the Plan of Borings, Plates 3A to 3J.

3.2 Sampling Methods

Soil samples were obtained continuously to a depth of approximately 10 feet and at 5-foot intervals thereafter to the maximum termination depth of the borings. Cohesive soil samples were obtained with a three-inch thin-walled (Shelby) tube sampler in general accordance with ASTM D-1587 standard. Granular soils were obtained using split spoon sampler in accordance with ASTM D 1586. Each sample was removed from the sampler in the field, carefully examined and then classified. The shear strength of the cohesive soils was estimated by a hand penetrometer in the field. Suitable portions of each sample were sealed and packaged for transportation to our laboratory.

Rock encountered was augured to the termination depth and evaluated by 'TxDOT' cone penetrometer test. 'TxDOT' cone penetrometer test was performed at approximately 5-foot intervals thereafter to the maximum termination depth. The test consists of driving a 3-inch diameter cone with a 170-pound hammer, which is dropped for a distance of 2 feet. The cone is seated and driven to 100 blows or 12 inches whichever comes first. Then it is driven for two consecutive 6-inch increments, and the blow counts for each increment are noted. In hard materials, the cone is driven with the resulting penetration in inches recorded for the 50 blows. The numbers of blows for each 6-inch increment and/or the amount of penetration for each 50 blows are presented on the boring logs.

Detailed descriptions of the soils encountered in the borings are given on the boring logs presented on Plates 4 through 13. A key to the soils and rock classification and symbols used in the boring logs are also presented on Plates 14A & 14B.

3.3 Groundwater Observations

Groundwater was not encountered in any borings during or after drilling operations. However, it should be noted that groundwater levels will fluctuate with seasonal changes in moisture conditions.

3.4 Borehole Completion

The borings were backfilled with soil cuttings and hydrated bentonite chips upon completion of drilling. The pavement was patched with asphalt at the surface so as to match the existing ground surface.

4 LABORATORY TESTING

4.1 Sample Examination and Classification Testing

Soil samples transported to our laboratory were further examined and identified in accordance with ASTM D 2488 – *Description and Identification of Soils*. A preliminary soil classification was assigned to each soil sample based on ASTM D 2487 – *Classification of Soil for Engineering Purposes*. Classification testing was subsequently conducted on select samples and the result of each test was used to confirm or modify the given preliminary soil classification.

4.2 Geotechnical Laboratory Testing

Selected soil samples were tested in the laboratory to determine applicable physical and engineering properties. All tests were performed according to the relevant ASTM Standards. These tests consisted of moisture contents, percent passing No. 200 sieve, Atterberg Limits, unconfined compression, unit weight and sulfates.

The Atterberg limits and percent passing No. 200 sieve tests were utilized to verify field classification by the Unified Soils Classification System, and the unconfined compression tests and hand penetrometer were utilized to obtain the undrained shear strength of the soil. The type and number of tests performed for this investigation are summarized below:

Type of Test	Number of Tests
Moisture Content (ASTM D2216)	23
Atterberg Limits (ASTM D4318)	10
Percent Passing No. 200 Sieve (ASTM D1140)	8
Hand Penetrometer	24
Unconfined Compression (Soil) (ASTM D 2166)	5
Unit Dry Weight (ASTM D 2166)	5
Sulfates (SW-846 9038)	3

The summary of laboratory test results is presented in Appendix A. The sulfates are presented in Appendix C.

5 SITE CHARACTERIZATION

5.1 Site Location

The project site is located on Belt Line Road in Addison, Texas. The borings were located from the intersection of Belt Line Road and Marsh Lane to the intersection of Belt Line Road and Midway Road. A site vicinity map is included in Plate 1.

5.2 General Geology

According to the University of Texas at Austin, Bureau of Economic Geology "Geologic Atlas of Texas Dallas Sheet," the project area lies within the border line of Eagle Ford group undivided (map symbol Kef) and Austin Chalk (map symbol Kau).

The Eagle Ford Group can consist of shale, sandstone and/or limestone but is mainly synonymous with shale within the area. Eagle Ford shale is characteristically bituminous and selenitic with calcareous concretions and large cracks in which it is not uncommon to find other minerals.

Austin Chalk (Kau) which dominantly consists of chalk, mostly microgranular calcite, and some interbeds and partings of calcareous clay in the upper and lower parts. Middle part mostly consists of thin-bedded marl with interbeds of massive chalk, locally burrowed, weathers and megafossils.

5.3 Soil Stratigraphy

Our interpretation of soil and groundwater conditions at the project site is based on information obtained at the boring locations only. This information has been used as the basis for our conclusions and recommendations. Significant variations at areas not explored by the project boring may require reevaluation of our findings and conclusions.

Stratum Types Encountered

Stratum Type	Approximate Depths of Strata Encountered at Borings (ft)									
	B-1	B-2	B-3	B-4	B-5	B-6	B-7	B-8	B-9	B-10
Pavement +Base	0-1.2	0-1.2	0-1.2	0-1.2	0-1	0-1	0-1	0-1	0-1	0-1
Fill⁽¹⁾	1.2-9.5	1.2-12.5	1.2-6.5	1.2-4.5	1-2.5	1-3	1-4 ⁽⁶⁾	1-7	1-2	1-4.5
Shaley Clay (CH)⁽²⁾	9.5-16	12.5-20 ⁽⁶⁾	6.5-13	-	-	-	-	-	-	-
Shale⁽³⁾	16-20 ⁽⁶⁾	-	13-20 ⁽⁶⁾	-	-	-	-	-	-	-

Stratum Type	Approximate Depths of Strata Encountered at Borings (ft)									
	B-1	B-2	B-3	B-4	B-5	B-6	B-7	B-8	B-9	B-10
Weathered Limestone ⁽⁴⁾	-	-	-	4.5-7.5	2.5-8	3-8	-	7-13	2-8	4.5-11.5
Unweathered Limestone ⁽⁵⁾	-	-	-	7.5-30 ⁽⁶⁾	8-20 ⁽⁶⁾	8-20 ⁽⁶⁾	-	13-20 ⁽⁶⁾	8-30 ⁽⁶⁾	11.5-20 ⁽⁶⁾

Note:

- (1) Fill; consists of sandy clay, clayey sand, fat clay and lean clay with gravels, calcareous deposits and weathered limestone.
- (2) Very stiff to hard.
- (3) Soft; occasional limestone seams.
- (4) Soft to hard.
- (5) Very hard.
- (6) Boring termination depth.

Detailed descriptions of the subsurface stratigraphy encountered in the borings are shown on the boring logs presented on Plates 4 through 13. A key to the soils and rock classification and symbols used in the boring logs are also presented on Plates 14A & 14B.

6 UTILITY DESIGN CRITERIA AND RECOMMENDATIONS

6.1 General

The project will involve construction of a new concrete or steel cased duct bank and telecommunications duct banks at depth of approximately 11 to 20 feet. Additionally there will be some smaller duct banks on both sides of the ROW for the entire length at depth of approximately 5 to 8 feet. We also assumed that all lines will be installed using open-cut and/or auguring techniques. Our analyses and recommendations for open cut and/or auguring techniques are presented below.

6.2 Geotechnical Parameters

Geotechnical design parameters are presented in the following table. These design parameters are based on field and laboratory test data obtained from the corresponding boring locations and at the approximate invert depth only. Please note that, because of the nature of the soil stratigraphy at this site, parameters at locations that deviate from the boring locations may vary substantially from values reported in the following table:

Boring No.	Approximate Invert Depth (ft)	Soil Description	Total Unit	Undrained Shear Strength (psf) or Friction Angle (deg)	Allowable Bearing Pressure (psf)
B1	5-9.5	FILL	125	1000	1500
B1	9.5-16	Very stiff to hard shaley clay	125	2500	4000
B1	16-20	Soft shale	130	3000	4500
B2	5-12.5	FILL	125	1000	1500

Boring No.	Approximate Invert Depth (ft)	Soil Description	Total Unit	Undrained Shear Strength (psf) or Friction Angle (deg)	Allowable Bearing Pressure (psf)
B2	12.5-20	Very stiff shaley clay	130	2500	4000
B3	5-6.5	FILL	125	1000	1500
B3	6.5-13	Very stiff shaley clay	125	1500	2500
B3	13-20	Soft shale	130	3000	4500
B4	5-7.5	Weathered limestone	130	N/A	4500
B4	7.5-20	Unweathered limestone	135	N/A	>10000
B5	5-8	Weathered limestone	130	N/A	4500
B5	8-20	Unweathered limestone	135	N/A	>10000
B6	5-8	Weathered limestone	130	N/A	4500
B6	8-20	Unweathered limestone	135	N/A	>10000
B8	5-7	FILL	125	1500	2500
B8	7-13	Weathered limestone	130	N/A	4500
B8	13-20	Unweathered limestone	135	N/A	>10000
B9	5-8	Weathered limestone	130	N/A	4500
B9	8-30	Unweathered limestone	135	N/A	>10000
B10	5-11.5	Weathered limestone	130	N/A	4500
B10	11.5-20	Unweathered limestone	135	N/A	>10000

The values shown in the above table represent our interpretation of the soil properties based on the available laboratory and field test data. Use of the soil properties shown above may or may not be appropriate for a particular analysis, since choice of design parameters often depends on whether total or effective stress analysis is used, rate of loading, duration of loading, geometry of loaded area, and other factors. The total unit weight values shown above represent our interpretation of soil unit weight at natural moisture content. The undrained shear strength and allowable bearing pressure values represent our interpretation of the shear strength in clay soils based primarily on the results of unconfined compression tests, and hand penetrometer tests. The allowable bearing pressures include a factor of safety of 3.

6.3 Pipe Installation recommendations

Pipe Design. The loads imposed on underground pipes depend principally upon the method of installation, the weight of overburden soils, roadway traffic load, and loads due to existing surface structures. For design of rigid pipes installed using open-cut excavation methods, loads due to overburden and traffic can be determined from Plate 16.

We understand that duct bank is under at least five (5) feet of cover in all locations. For pipes with five or more feet of cover, the traffic loads may be taken as a surcharge equivalent to 250 psf.

The design of flexible pipes requires the modulus of soil reaction of the native soil (E_n') in the trench wall as input. The E_n' values are based on empirical relationships to the soil consistency as

defined by unconfined compression tests for cohesive soils. E_n' values for the native soils are presented in the following table. The E_n' values for short-term conditions in cohesive soils may be assumed to be 1.5 times the long-term values. These values are based on the soil data obtained at the boring locations only and may be used for the noted invert depth zone.

Boring No.	Approximate Invert Depth (ft)	Soil Description	Total Unit	E_n' , Long Term (psf)
B1	5-9.5	FILL	125	300
B1	9.5-16	Very stiff to hard shaley clay	125	1000
B1	16-20	Soft shale	130	2000
B2	5-12.5	FILL	125	300
B2	12.5-20	Very stiff shaley clay	130	1000
B3	5-6.5	FILL	125	300
B3	6.5-13	Very stiff shaley clay	125	800
B3	13-20	Soft shale	130	1000
B4	5-7.5	Weathered limestone	130	2000
B4	7.5-20	Unweathered limestone	135	3000
B5	5-8	Weathered limestone	130	2000
B5	8-20	Unweathered limestone	135	3000
B6	5-8	Weathered limestone	130	2000
B6	8-20	Unweathered limestone	135	3000
B8	5-7	FILL	125	600
B8	7-13	Weathered limestone	130	2000
B8	13-20	Unweathered limestone	135	3000
B9	5-8	Weathered limestone	130	2000
B9	8-30	Unweathered limestone	135	3000
B10	5-11.5	Weathered limestone	130	2000
B10	11.5-20	Unweathered limestone	135	3000

Pipe Bedding and Backfill. Based on the soil borings, it can be expected that lean clays, clayey sands to sandy clays, weathered limestone, or unweathered limestone will be encountered within the bedding zone. We recommend that pipe bedding be in accordance with Item 504.2.2 and backfill be in accordance with Item 504.6 of North Central Texas Council of Governments (NCTCOG) standard specification.

Compact bedding and backfill material should be laid in 8-inch lifts to 95% of the maximum density, as measured by ASTM D 698. The bottom of the excavation should be dry before the placement of the pipe. If required, we recommend groundwater control be implemented, if required, to achieve stable trench conditions and a satisfactory foundation base.

The excavations should be performed with equipment capable of providing a relatively clean bearing area. Stable soils are essential to provide a strong base during construction. In addition, stable soils enhance trench bottom stability, support for bedding compaction, and minimize possible pipe settlement. Whenever soft foundation soils are encountered during trench excavation we recommend over-excavating 3 feet below the base of the foundation and replacing with on-site soils compacted to at least 95% of maximum dry density in loose lifts not exceeding 8 inches.

The pipes should be installed in a bedding envelope. Bedding materials selected for the project may include pea gravel, uncrushed gravel, crushed gravel, crushed stone, stone screenings, and natural/manufactured sand. Based on ASTM C1479M, these materials are expected to fall in category I consisting of well graded sand (SW), poorly graded sand (SP), well graded gravel (GW), or poorly graded gravel (GP). We also recommend flowable fill be used where the groundwater level is above the proposed invert depth. During placing flowable fill, dewatering should be performed to maintain the bottom of excavation dry.

ASTM C 1479 categorizes soil into four different groups based on which one can determine if that soil can be used as bedding, embedment or backfill material for rigid and/or semi-rigid pipes. This information is presented in Table below and can be generalized for both rigid and flexible pipes.

Soil Categories as per ASTM C1479M

Soil Category	USCS Classifications
Category I	SW, SP, GW, GP
Category II	GM, GC, SM, SC with more than 12% fines CL, ML, CL-ML with more than 30% retained on 75 µm sieve
Category III	CL, ML, CL-ML with less than 30% retained on 75 µm sieve
Category IV	MH, CH, OL, OH, PT

If these category I soils are used for bedding, category II soils are recommended for embedment to prevent particle migration between different size of soil particles. Category II or Category III can be used for backfilling the trenches. Native clayey sands to sandy clays can be considered as Category II. Native lean clays encountered in the borings can be considered as Category III, and they contained occasional sand.

The bedding material must be compatible with the materials in the trench bottom, walls, and backfill so that particle migration from, into, or through the bedding is minimized. Particle migration can occur when open-graded material is placed adjacent to a finer material like silt. Under the action of hydraulic gradient from groundwater flow, fines may migrate into the coarser material. The gradation and relative size of the embedment and adjacent materials must be compatible in order to minimize migration.

Trench Backfill. For pipes that will be located under streets or within one foot of streets and curbs, pipe embedment should extend to a minimum of 6 inches above the top of pipe. Trench zone backfill is that portion of trench backfill that extends vertically from the top of pipe embedment up to pavement subgrade or up to final grade when not beneath pavement. Trenches that are located partially within the limit of one foot from streets or curbs should be uniformly backfilled according to the paved area criteria. Backfill material may consist of in-situ soils or imported flexible base materials. Fill material should be placed in loose lifts not exceeding six (6) inches, and should be compacted to 95% of the standard proctor maximum dry density as determined by ASTM D 698.

However, the backfill up to 12 inches above the top of the pipe should be compacted so as to prevent structural damage to the pipe.

It is common practice to use the material excavated from the trench as trench backfill regardless of the plasticity index of the soil excavated from the trench. However, we recommend either Type-B backfill in accordance with North Central Texas Council of Governments (NCTCOG) Standard Specifications Item 504.2.3.3. or Flowable backfill in accordance with North Central Texas Council of Governments (NCTCOG) Standard Specifications Item 504.2.3.4. Excavated materials meeting type B can be reused for the trench backfill.

7 UTILITY CONSTRUCTION CONSIDERATIONS

7.1 General

This section is intended to address issues that might arise during construction. Our recommendations are intended for use as guidelines in dealing with particular soil conditions. The topics addressed in this section include trench excavation stability, groundwater control, open-cut construction and trenchless technique construction considerations.

The recommendations contained herein are not intended to dictate construction methods or sequences. Instead they are provided solely to assist designers in identifying potential construction problems related to excavation, based upon findings derived from sampling. Depending upon the final design chosen for the project, the recommendations may also be useful to personnel who observe construction activity.

Prospective contractors for the project must evaluate potential construction problems on the basis of their review of the contract documents, their own knowledge of and experience in the local area, and on the basis of similar projects in other localities, taking into account their own proposed methods and procedures.

7.2 Boring, Jacking, or Tunneling Construction Considerations

We understand that at some locations the pipeline will be installed using trenchless techniques. Three basic criteria exist for satisfactory construction. First, construction must be feasible which means that it is possible to advance the bore safely and to maintain the integrity of the bore opening at least temporarily. Second, the construction should not result in excessive damage to adjacent or overlying structures, streets, or utilities. Third, the long-term design objectives of the facility must be achieved. A summary of the construction conditions for the project is given below.

Pipe Design. For pipes to be installed by trenchless techniques, whereby sections of pipe are jacked forward against the surrounding soil, pipes should be designed to resist significant bending moments, along with the jacking forces exerted on the pipe during installation. These loads generally exceed the overburden pressures that are typically determined based on the prism earth load to the ground surface, plus hydrostatic pressure and surcharge loads as shown on Plate 15. Therefore, pipes designed to resist construction loads during trenchless installation should have adequate strength for most long-term overburden and traffic loads.

During design, allowance should be made for any external loads, other than soil and rock loads, which may be exerted on the pipe. These include loads from foundations for structures located near the water line and any possible future excavation to be performed near the water line. Much of the stability of the waterlines is due to the presence of relatively uniform stress conditions in the soil around the pipe. Relief of the earth loads on one side of the waterline due to subsequent adjacent excavation could cause an overstress of the pipe.

Alignment. Constructability is determined to a large extent by the type of soil or rock. The best conditions are full-faced conditions. Situations that are more difficult are mixed face conditions where two different types of soil and rock, or two different types of rock are encountered in the excavation face simultaneously. These tunneling conditions should be avoided whenever possible.

We do anticipate mixed face conditions at most of the bores at the proposed invert depths. Where mixed face conditions are encountered control of the grade of the face of excavation is more difficult to control, and local instability of the face of the excavation is more likely at and near locations where the boundary between two strata is exposed in the excavation.

Face of Excavation Stability. The stability of the face is a function of the shear strength and stress-strain characteristics of the soil or rock, the overburden pressure, the geometry of the cross section, the time-dependent loss of strength, the delayed deformation of some soils, and the construction procedures. When the face consists of more than one kind of soil or rock, the stability of such a face may be assessed by analyzing the different materials independently.

For the cohesive soil materials that may be encountered the stability of a face is determined by its existing undrained shear strength. The stability of the unsupported face of the excavation may be evaluated by a ratio of the overburden pressure divided by the undrained shear strength of the soil assuming atmospheric air pressure in the tunnel. This ratio is referred to as the Overload Factor, OF. Based on the measured soil properties, OF values were 3.0 or less.

Generally, a design value for the overload factor of 4 or less is desirable in cohesive soils. A value of 4 represents a practical limit below which trenchless construction may be carried out without difficulties. Higher OF values will frequently lead to large deformations of the soil around and ahead of the excavation, with the associated problem of increased subsidence and possible deformations. It should be noted; however, that exposure time of the face is the most important. At the moment of excavation, negative pore pressures are generated. If the soil is left under the same conditions, the pore pressures will dissipate resulting in a reduction of shear strength. Thus, if a slow rate of advance is expected, a higher value of the OF must be used (or a reduced corrected value for the undrained shear strength).

Fill material from road grading or in old utility trenches may be encountered. A potential for face instability exists where weak fill soils are encountered. The contractor should be aware of these conditions and make provisions to avoid loss of ground where fill is encountered.

Loss of Ground. A properly designed and controlled operation can eliminate or reduce immediate soil movement and subsidence to a tolerable level. Nevertheless, some ground loss should be expected during trenchless operation. With good construction techniques, ground loss can be held to acceptable levels. Generally, pipes bored or jacked beneath pavement and buried utilities can be expected to create a loosened subgrade or bedding condition which may lead to subsequent deformations. Advance rate and excavation rate should be compatible to avoid over excavation or loss of ground in order to minimize deformations.

Groundwater may be encountered during tunneling operation. We recommend that equipment providing positive support to the face, such as earth pressure balance equipment, be used when constructing this segment of the project.

Large ground loss can result from uncontrolled flowing ground. The potential for such ground loss exists wherever water-bearing sands or silts are encountered along the alignment. Careful dewatering of such layers will reduce the potential for development of flowing conditions. These soils were not encountered, however, if they are encountered during construction tunneling should be halted and measures need to be taken to dewater the area.

Ground Surface Movements. The zone of influence of a trenchless crossing extends a distance equal to the invert depth on each side of the centerline of the alignment. No building structures are anticipated to be in the zone of influence. The utility lines located adjacent to or crossing the alignment may experience movement caused by trenchless excavation. Settlement of the utility lines should be within acceptable limits provided good construction practices are followed. Long-term vertical movements caused by consolidation of the ground above the tunnel will occur if leakage into the liner or the sewer pipes impacts groundwater levels in the project area

7.3 Open-Cut Excavation Considerations

Excavations should satisfy two requirements. First, the soils above final grade must be removed without disturbing the soil below excavation grade, which will support constructed facilities. Second, the sides of the excavation must be stable to prevent damage to adjacent streets and facilities as a result of either vertical or lateral movements of the soil. In addition, a satisfactory excavation procedure must include an adequate construction dewatering system to lower and maintain the water level at least a few feet below the lowest excavation grade.

We understand that excavations approaching 20 feet in the center lane of Belt Line will be needed. Due to the limited space, braced excavation will be needed.

Excavation Stability. Excavations shall be shored, laid back to a stable slope or some other equivalent means may be used to provide safety for workers and adjacent structures. Earth pressures for braced excavations are presented on Plate 15. Assessment of the need for excavation, use of trench boxes or other measures required providing a stable excavation and the use of appropriate construction practices and/or equipment is the contractor's responsibility. The following comments are intended to represent common solutions to stability problems encountered in similar soil conditions in the Dallas area, and may not be construed as excavation system design recommendations. The excavation operations shall be performed in accordance with 29 CFR Part 1926 subpart P, as amended, including rules published in the Federal Register, Vol. 54, No. 209, dated October 31, 1989, as a minimum. In addition, the provisions of legislation enacted by the Texas Legislature should be satisfied.

In general, it is our opinion that the pressure distribution (for braced walls) should be used for design of sheeting or trench boxes. To reduce the potential for ground movement adjacent to the top of the excavation, the bracing should be preloaded in stages as the excavation is deepened. The detailed earth pressure diagrams are presented on Plate 15.

The planned construction will be performed along alignments near existing utility installations (either crossing or paralleling the new alignments). The contractors should be aware of potential excavation stability problems while working in the vicinity of old trenches and the excavation system should be designed to accommodate this weak material (trench backfill).

The vertical walls of excavations should be located a safe distance from existing utilities in order to prevent movement in the soil mass behind the excavation that may adversely affect the utilities

7.4 **Lateral Earth Pressures**

The pressures which a soil can be expected to exert on the duct bank depend on the type of soil and the construction technique. If the construction method encompasses backfilling along the exterior walls of the underground duct bank, then the lateral earth pressures become a function of the type of backfill and its method of placement. If construction is performed by incorporating temporary excavation sheeting as part of the permanent structure, then the lateral earth pressures would vary with the type of the existing soil.

For a backfill type of soil, the following considerations should be taken into account when estimating lateral earth pressure acting on the walls of a permanent underground duct bank.

1. Over-compaction of backfill and utilization of highly plastic expansive clay backfill are practices, which generally produce the highest wall pressures. In these cases, horizontal earth pressures exceeding the vertical pressure can be expected. Backfill selection and method of placement are critical.
2. Bank sand, cement stabilized sand and select cohesive soil are some types of fill material that can be considered for this project. Bank sand is silty fine sand which contains no more than 15 percent material by weight passing the number 200 sieve, clay lumps or balls not exceeding 2 percent, and free of debris. Select cohesive soil should have a plasticity index between 7 and 20.

Most of the excavated soils from this site are expected to be mostly cohesive soils. The backfill to be used should be tested prior to use as explained in the following section.

The backfill around the underground structures will impose active to at rest earth pressures against the embedded walls. Design lateral pressures may be calculated for each backfill type using the following equivalent fluid densities for drained or undrained level backfill:

Strata	Equivalent Fluid Pressure (Drained)	
	At-rest (rigid), pcf	Active (flexible), pcf
Sandy Clay or Select Fill (PI≤20)	70	50
On-site Sand, Bank Sand, Gravel, or Cement Stabilized Sand	55	35
Cohesive Soil (PI≥20)	90	70

7.5 Groundwater Control

Assessment of the need for groundwater control and installation of appropriate dewatering equipment is the contractor's responsibility. The following comments are intended to represent common solutions to groundwater control problems encountered in similar soil conditions in the Dallas area, and may not be construed as dewatering system design recommendations.

A conventional pump and sump arrangement may be adequate if water bearing cohesive soils are encountered during trench excavations. Well points or eductors may be utilized to lower the groundwater level to at least three feet below the excavation level where water bearing cohesionless soils are encountered. Well points are generally not effective below about 15 feet beneath the top of the well point, and deeper dewatering requires deep wells with submersible pumps and eductors. Based on the subsurface soils encountered, we anticipate groundwater to be controlled using either pump and sump arrangement or well points. In any case, the groundwater control system used must provide a relatively dry, stable base for construction. However, it should be noted that groundwater conditions will change due to rainfall and seasonal changes.

Control of groundwater should be accomplished in a manner that will preserve the strength of the foundation soils; will not cause instability of the excavation; and will not result in damage to existing

structures. Where necessary to this purpose, the water will be lowered in advance of excavation by pump and sump arrangement, wells, well points, or similar methods. Open pumping should not be permitted if it results in boils, loss of fines, softening of the subgrade, or excavation instability. Discharge should be arranged to facilitate sampling by the owner's representative or engineer.

8 MONITORING

8.1 Excavation Safety

As required under OSHA regulations, the contractor should provide a "competent person" to inspect trench excavations daily before the start of work, as needed during the shift, and after every rainstorm or other hazard increasing occurrence. When the competent person finds evidence of a hazardous condition, exposed workers should be removed from the hazardous area until the necessary precautions have been taken to ensure their safety. A competent person means one who is capable of identifying existing and predictable hazards in the surroundings or working conditions which are unsanitary, hazardous or dangerous to workers, and who has authorization to take prompt corrective measures to eliminate them.

8.2 Construction Materials Testing

In-place density/moisture content shall be tested and verified as specified by the owner, or at an average frequency of once per 300-linear-feet per 1-foot of compacted depth in accordance with NCTCOG Section 504.5.3.2. We recommend that backfill be monitored by an accredited testing laboratory to verify that construction is performed in conformance with project specifications. HVJ Associates routinely provides these services and would be pleased to do so for this project.

9 PAVEMENT DESIGN RECOMMENDATIONS

9.1 General

We understand that the project will also involve reconstruction of the pavement surface along the existing Belt Line Road between Midway Road and Marsh Lane to match with the existing pavement surface. The existing pavement structure is concrete pavement with asphalt overlay. We recommend the following requirements for pavement cut and repair preparation.

1. Match existing concrete and asphalt thickness to minimum thickness of current standard for the street type.
2. Replaced Class P2 concrete should meet the following mix design requirements in accordance with 2011 Addendum to the North Central Texas Council of Government (NCTCOG) Standard Specifications Item 303.3.3.1.
 - Minimum compressive strength: 4500 psi @ 28 days
 - Minimum sacks of cement required: 6.5 sacks or 611 lbs./ cu. yd. of concrete
 - Fly ash may be used in all classes of concrete for paving to replace a portion of the minimum Portland cement.

- The maximum amount of fly ash allowed is 20% by weight of cement (i.e.) 20% of cement reduction. Addendum specification requires 1.25 lbs. of Class C fly ash for each lb. of Portland cement substituted. Natural pozzolans or fly ash (ASTM Designation C-618) may be utilized in accordance with North Central Texas Standard Specification Item 303.2.4 provided that the “loss on ignition” of the fly ash shall not exceed 3%.
 - Maximum slump allowed: 3-5 inches
 - Maximum water/cement ratio: 0.45 lbs. water per /lbs. Cement.
 - Air Entraining is required (Range 3.5% to 8.5%)
 - Concrete as placed shall contain the proper amount of air required herein with tolerance of plus or minus 1.5%.
3. The backfill material should be either Type-B backfill in accordance with North Central Texas Council of Governments (NCTCOG) Standard Specifications Item 504.2.3.3. or Flowable backfill in accordance with North Central Texas Council of Governments (NCTCOG) Standard Specifications Item 504.2.3.4.
 4. Type B backfill shall consist of native or imported material. Type B backfill should meet the requirements include liquid limit shall not exceed 35, plasticity index shall not exceed 12 and percentage pass No. 200 sieve shall not exceed 35. Bedding and backfill material should be laid in loose 8-inch lifts and compacted to 95% of the maximum density, as measured by ASTM D 698.
 5. Flowable backfill shall consist of a mixture of native soils or manufactured materials, cement and water which produces a material with unconfined compressive strength between 250 psi and 450 psi after 28 days. Any materials used shall be primarily granular with PI less than 12 and with 100% passing a ¾-inch sieve.

9.2 Preparation of Subgrade

The subgrade soils along the pavement alignment generally consist of both cohesive and cohesionless soils. We recommend that at least eight (8) inches of the subgrade be stabilized for full depth concrete pavement construction. Six (6) inches of flexible base could be used instead of lime stabilization. Stabilization of the subgrade should increase the modulus of subgrade reaction and provide subgrade stability for construction during inclement weather. In addition, subgrade stabilization should enhance long-term pavement performance by reducing the tendency of the soil to displace by pumping. We recommend the following procedures for subgrade preparation.

1. Clear the existing pavement section.
2. Strip the surface soil to suitable depths. In areas where soft, compressible or loose soils are encountered, additional stripping may be required.
3. All areas beneath proposed pavement shall be proof rolled to detect areas of weakness prior to placement of fill material. In cut areas, the soil shall be proof rolled after excavation is completed to final subgrade elevation in accordance with North Central

Texas Council of Governments (NCTCOG) Standard Specifications Item 301.1.1.3.4. If subgrade stabilization is not performed, the upper eight (8) inches of subgrade soil shall be compacted at minus two (2) to plus four (4) percentage points of optimum moisture to a minimum of 98% Standard Proctor density (ASTM D 698). It is proposed to use a contact pressure corresponding as nearly as practical to the maximum supporting value of the earthwork or base. A minimum of two coverages of the proof roller will be required. Each succeeding trip of the proof roller shall be offset by not greater than one tire width.

4. For stabilized subgrade, the rate of lime required shall be determined by the owner using an adjusted rate (normally up to 20 percent boost) above the laboratory determined rate required to reduce the PI of the lime treated on-site subgrade soils to 15. The adjusted rate used for clay subgrade soils shall not be less than 4% commercial hydrated lime per dry weight of subgrade soil (for 6 inch depth treatment - 22 lbs per square yard; for 8 inch depth treatment - 29 lbs per square yard) for subgrade soils having a liquid limit less than 50. The adjusted rate used for clay subgrade soils having a liquid limit of 50 or greater shall not be less than 6% commercial hydrated lime per dry weight of subgrade soil (for 6 inch depth treatment - 32 lbs per square yard; for 8 inch depth treatment - 43 lbs per square yard). Compaction of the mixture shall begin immediately after final mixing and in no case later than three (3) days after final mixing. The compacted mixture shall have a uniform density of not less than 98 percent of the maximum density as determined by ASTM D 698.

10 DESIGN REVIEW

HVJ Associates, Inc. should review the design and construction plans and specifications prior to release to make certain that the geotechnical recommendations presented herein have been properly interpreted. Our current scope of services does include an allowance for such review.

11 LIMITATIONS

This investigation was performed for the exclusive use of Town of Addison, Infrastructure & Operations Services to provide geotechnical investigations for the proposed Belt Line Road Street Improvements in Addison, Texas. HVJ Associates, Inc. has endeavored to comply with generally accepted geotechnical engineering practice common in the local area. HVJ Associates, Inc. makes no warranty, express or implied. The analyses and recommendations contained in this report are based on data obtained from subsurface exploration, laboratory testing, the project information provided to us and our experience with similar soils and site conditions. The methods used indicate subsurface conditions only at the specific locations where samples were obtained, only at the time they were obtained, and only to the depths penetrated. Samples cannot be relied on to accurately reflect the strata variations that usually exist between sampling locations. Should any subsurface conditions other than those described in our boring logs be encountered, HVJ Associates, Inc. should be immediately notified so that further investigation and supplemental recommendations can be provided.

PLATES

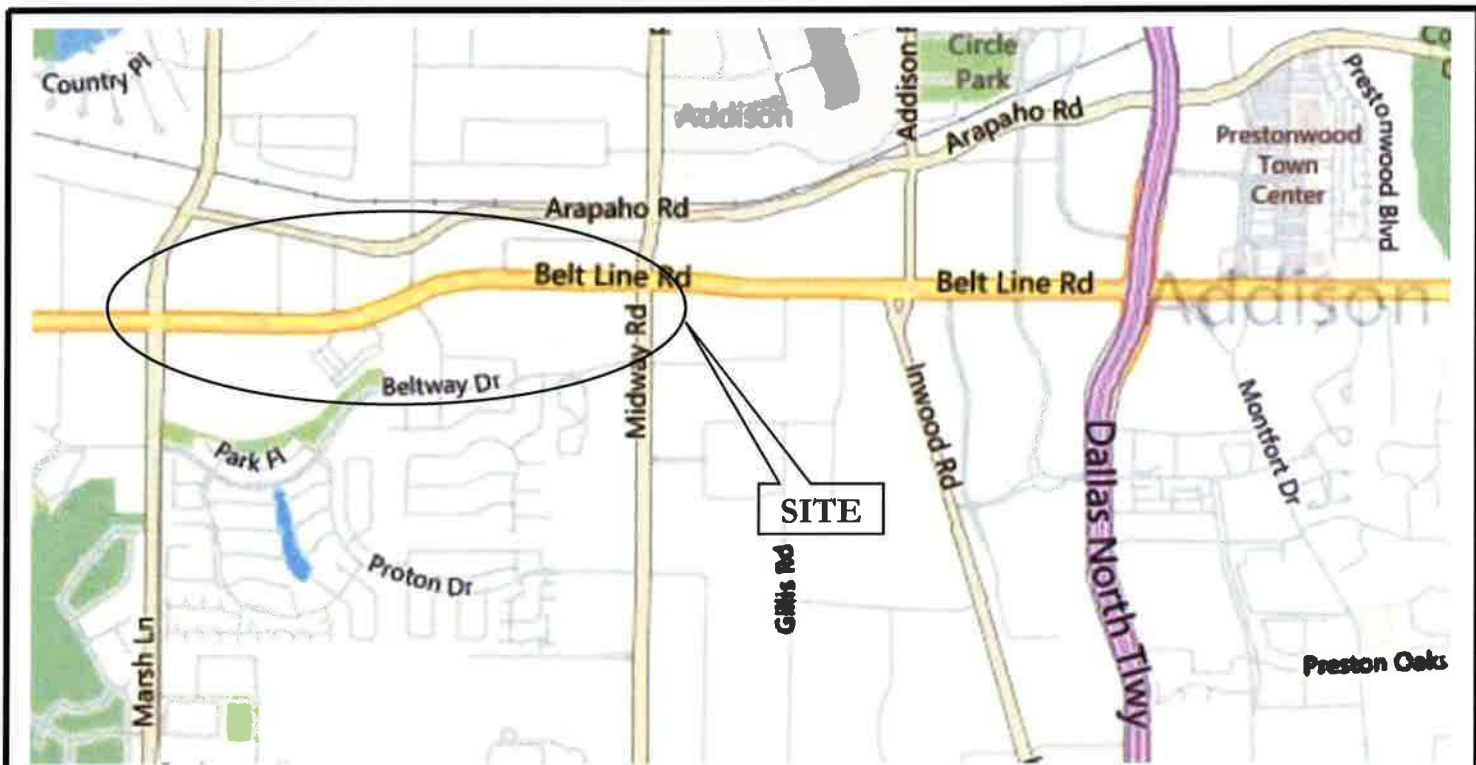

SITE

Gillis Rd



Source: ESRI ARCGIS Explorer
USGS Bing Base Maps

		
<small>8701 John Carpenter Pkwy Suite 250 Dallas, TX 75247 214-678-0227 Ph. 214-678-0138 Fax</small>		
DATE: 11/26/2013	APPROVED BY: JP	PREPARED BY: SS
SITE VICINITY MAP BEL'LINE ROAD From Marsh Lane To Midway Road		
PROJECT NO.: DG-12-15641	DRAWING NO.: PLATE 1	



Kef: Eagle Ford formation
 Kau: Austin Chalk

Source: Geologic Atlas of Texas Dallas Sheet
 UT Austin Bureau of Economic Geology



8701 John Carpenter Fwy Suite 254
 Dallas, TX 75247
 214.628.0227 Ph
 214.628.0228 Fax

DATE: 11/26/2013

APPROVED BY: JP

PREPARED BY: SS

GEOLOGY MAP
 BELTLINE ROAD

From Marsh Lane To Midway Road

PROJECT NO.: DG-12-15641

DRAWING NO.: PLATE 2



⊕ Approximate Boring locations



8701 John Carpenter Freeway Suite 350
Dallas, TX 75247
214-678-0227 Pk
214-678-0238 Fax

DATE: 12/17/13

APPROVED BY: JP

PREPARED BY: SS

PLAN OF BORINGS - I
BELTLINE ROAD

PROJECT NO.: DG-12-15641

DRAWING NO.: PLATE 3A



⊕ Approximate Boring locations



		8701 John Carpenter Fwy Suite 250 Dallas, TX 75247 214-678-0237 Ph 214-678-0238 Fax	
DATE: 12/17/13	APPROVED BY: JP	PREPARED BY: SS	
PLAN OF BORINGS - II BELTLINE ROAD			
PROJECT NO.: DG-12-15641		DRAWING NO.: PLATE 3B	



⊕ Approximate Boring locations



8701 John Carpenter Fwy Suite 250
 Dallas, TX 75247
 214 678 0227 Ph
 214 678 0228 Fax

DATE: 12/17/13

APPROVED BY: JP

PREPARED BY: SS

PLAN OF BORINGS - III
 BELTLINE ROAD

PROJECT NO.: DG-12-15641

DRAWING NO.: PLATE 3C



⊕ Approximate Boring locations



8701 John Carpenter Fwy Suite 250
 Dallas, TX 75217
 214-678-8333 PB
 214-678-0228 Fax

DATE: 12/17/13

APPROVED BY: JP

PREPARED BY: SS

PLAN OF BORINGS - IV
 BELTLINE ROAD

PROJECT NO.: DG-12-15641

DRAWING NO.: PLATE 3D



⊕ Approximate Boring locations



8701 John Carpenter Frey Suite 350
Dallas, TX 75217
214-678-0227 PH
214-678-0228 FAX

DATE: 12/17/13

APPROVED BY: JP

PREPARED BY: SS

PLAN OF BORINGS - V
BELTLINE ROAD

PROJECT NO.: DG-12-15641

DRAWING NO.: PLATE 3E



 Approximate Boring locations



8703 John Carpenter Frey Suite 204
 Dallas, TX 75247
 214 678 0222 Ph
 214 678 0228 Fax

DATE: 12/17/13

APPROVED BY: JP

PREPARED BY: SS

PLAN OF BORINGS - VI
 BELTLINE ROAD

PROJECT NO.: DG-12-15641

DRAWING NO.: PLATE 3F



 Approximate Boring locations



8701 John Carpenter Frey Suite 250
 Dallas, TX 75247
 214-678-0237 Ph
 214-678-0238 Fax

DATE: 12/17/13

APPROVED BY: JP

PREPARED BY: SS

PLAN OF BORINGS - VII
 BELTLINE ROAD

PROJECT NO.: DG-12-15641

DRAWING NO.: PLATE 3G



⊕ Approximate Boring locations



8709 John Carpenter Fry Suite 250
 Dallas, TX 75247
 214-678-0227 Ph
 214-678-0328 Fax

DATE: 12/17/13

APPROVED BY: JP

PREPARED BY: SS

PLAN OF BORINGS - VIII
 BELTLINE ROAD

PROJECT NO.: DG-12-15641

DRAWING NO.: PLATE 3H



⊕ Approximate Boring locations



8701 John Carpenter Fry Suite 250
Dallas, TX 75247
214-678-0237 Pk
214-678-0238 Fax

DATE: 12/17/13

APPROVED BY: JP

PREPARED BY: SS

PLAN OF BORINGS - IX
BELTLINE ROAD

PROJECT NO.: DG-12-15641

DRAWING NO.: PLATE 3I



 Approximate Boring locations



8701 John Carpenter Fwy Suite 350
Dallas, TX 75247
214 678 0227 Ph
214 678 0228 Fax

DATE: 12/17/13

APPROVED BY: JP

PREPARED BY: SS

PLAN OF BORINGS - X
BELTLINE ROAD

PROJECT NO.: DG-12-15641

DRAWING NO.: PLATE 3J

LOG OF BORING

Project: Beltline Road

Boring No.: B- 1

Groundwater during drilling: Dry

Groundwater after drilling: ---

Date: 10/28/2013

Northing: --

Easting: --

Project No.: DG-12-15641

Elevation:

Appx. Station: 12+80

Appx. Offset: 15' RT

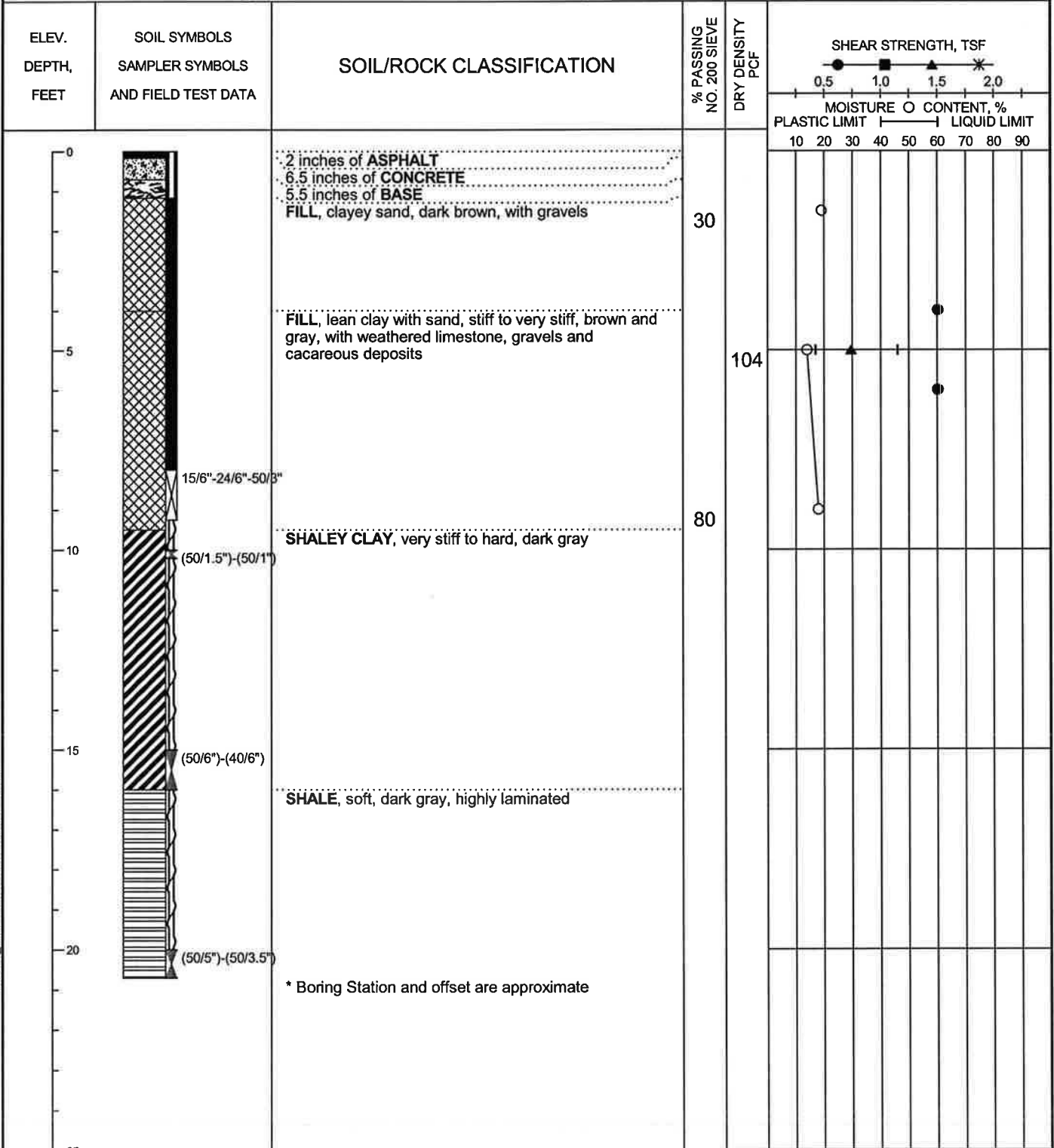

Shear Types: ● = Hand Penet. ■ = Torvane ▲ = Unconf. Comp. ✱ = UU Triaxial

LOG OF SOIL BORING DG-12-15641 BELTLINE ROAD WITH LAB.GPJ HVJ.GDT 2/5/14

LOG OF BORING

Project: Beltline Road

Boring No.: B-2

Groundwater during drilling: Dry

Groundwater after drilling: ---

Date: 10/28/2013

Northing: --

Easting: --

Project No.: DG-12-15641

Elevation:

Appx. Station: 18+00

Appx. Offset: 6' RT

ELEV. DEPTH, FEET	SOIL SYMBOLS SAMPLER SYMBOLS AND FIELD TEST DATA	SOIL/ROCK CLASSIFICATION	% PASSING NO. 200 SIEVE	DRY DENSITY PCF	
<div style="display: flex; align-items: center;"> <div style="flex: 1;"> <p>0</p> <p>5</p> <p>10</p> <p>15</p> <p>20</p> <p>25</p> </div> <div style="flex: 2;"> </div> </div>	<p>2 inches of ASPHALT</p> <p>5.5 inches of CONCRETE</p> <p>6.5 inches of BASE</p> <p>FILL, lean clay, stiff to very stiff, brown and gray, with gravels and cacareous deposits</p> <p>FILL, lean clay clay with sand, soft to stiff, brown and gray, with gravels and cacareous deposits</p> <p>FILL, clayey sand, brown and gray, with weathered limestone, gravels and cacareous deposits</p> <p>SHALEY CLAY, fat, very stiff, dark gray, with weathered limestone seams</p> <p style="margin-left: 20px;">(50/5.5")-(50/6")</p> <p style="margin-left: 20px;">(32/6")-(38/6")</p>	<p>2 inches of ASPHALT</p> <p>5.5 inches of CONCRETE</p> <p>6.5 inches of BASE</p> <p>FILL, lean clay, stiff to very stiff, brown and gray, with gravels and cacareous deposits</p> <p>FILL, lean clay clay with sand, soft to stiff, brown and gray, with gravels and cacareous deposits</p> <p>FILL, clayey sand, brown and gray, with weathered limestone, gravels and cacareous deposits</p> <p>SHALEY CLAY, fat, very stiff, dark gray, with weathered limestone seams</p>	<p>90</p> <p>72</p> <p>45</p> <p>80</p>	<p>102</p>	<p>● = Hand Penet.</p> <p>■ = Torvane</p> <p>▲ = Unconf. Comp.</p> <p>* = UU Triaxial</p>

* Boring Station and offset are approximate

Shear Types:

● = Hand Penet. ■ = Torvane ▲ = Unconf. Comp. * = UU Triaxial

LOG OF SOIL BORING DG-12-15641 BELTLINE ROAD WITH LAB.GPJ HVJ.GDT 2/5/14

LOG OF BORING

Project: Beltline Road
 Boring No.: B- 3
 Groundwater during drilling: Dry
 Groundwater after drilling: ---

Date: 10/29/2013
 Northing: --
 Easting: --

Project No.: DG-12-15641
 Elevation:
 Appx. Station: 22+30
 Appx. Offset: 9' RT

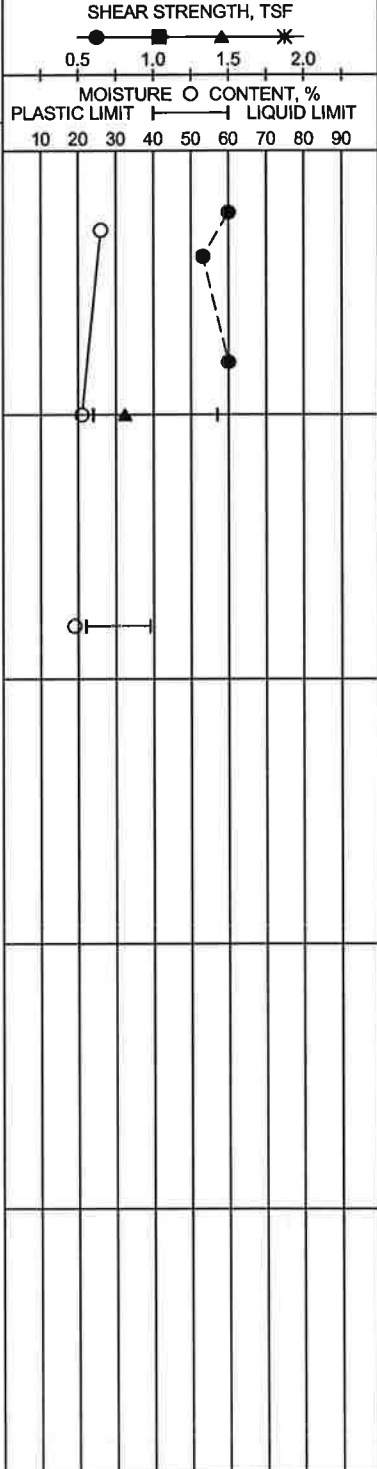
ELEV. DEPTH, FEET	SOIL SYMBOLS SAMPLER SYMBOLS AND FIELD TEST DATA	SOIL/ROCK CLASSIFICATION	% PASSING NO. 200 SIEVE	DRY DENSITY PCF	<div style="text-align: center;"> SHEAR STRENGTH, TSF 0.5 1.0 1.5 2.0 ● ■ ▲ ✱ MOISTURE CONTENT, % PLASTIC LIMIT LIQUID LIMIT 10 20 30 40 50 60 70 80 90 </div>
0		2 inches of ASPHALT 7 inches of CONCRETE 5 inches of BASE FILL, fat clay, stiff to very stiff, brown and gray, with weathered limestone, gravels and cacareous deposits 23/8"-31/8"-17/5" SHALEY CLAY, lean, very stiff, dark gray 13/8"-5/6"-8/6" SHALE, soft, dark gray, with limestone seams (30/6")-(32/6") (50/5")-(50/3")	88	102	
25		* Boring Station and offset are approximate			

Shear Types: ● = Hand Penet. ■ = Torvane ▲ = Unconf. Comp. ✱ = UU Triaxial

LOG OF SOIL BORING DG-12-15641 BELTLINE ROAD WITH LAB.GPJ HVJ.GDT 2/5/14

LOG OF BORING

Project: Beltline Road

Project No.: DG-12-15641

Boring No.: B- 4

Date: 10/29/2013

Elevation:

Groundwater during drilling: Dry

Northing: --

Appx. Station: 28+30

Groundwater after drilling: ---

Easting: --

Appx. Offset: 6' RT

ELEV. DEPTH, FEET	SOIL SYMBOLS SAMPLER SYMBOLS AND FIELD TEST DATA	SOIL/ROCK CLASSIFICATION	% PASSING NO. 200 SIEVE	DRY DENSITY PCF	<div style="text-align: center;"> SHEAR STRENGTH, TSF </div> <div style="text-align: center;"> MOISTURE CONTENT, % PLASTIC LIMIT LIQUID LIMIT </div>
0		2 inches of ASPHALT 7 inches of CONCRETE 5 inches of BASE FILL, fat clay, very stiff, brown and gray, with weathered limestone, gravels and calcareous deposits	90	89	<div style="text-align: center;"> </div>
5		LIMESTONE, hard, tan, weathered			
10		LIMESTONE, very hard, gray			
15					
20					

Shear Types:

● = Hand Penet. ■ = Torvane ▲ = Unconf. Comp. ※ = UU Triaxial

* Boring Station and offset are approximate

PLATE 7a

LOG OF BORING

Project: Beltline Road
 Boring No.: B-4
 Groundwater during drilling: Dry
 Groundwater after drilling: ---

Date: 10/29/2013
 Northing: --
 Easting: --

Project No.: DG-12-15641
 Elevation:
 Appx. Station: 28+30
 Appx. Offset: 6' RT

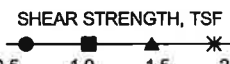
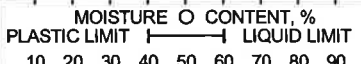
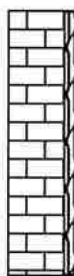
ELEV. DEPTH, FEET	SOIL SYMBOLS SAMPLER SYMBOLS AND FIELD TEST DATA	SOIL/ROCK CLASSIFICATION	% PASSING NO. 200 SIEVE	DRY DENSITY PCF	<div style="text-align: center;"> SHEAR STRENGTH, TSF  </div> <div style="text-align: center;"> MOISTURE CONTENT, % PLASTIC LIMIT LIQUID LIMIT  </div>
25	 (50/0.125")-(50/0.125")	LIMESTONE , very hard, gray			
30	(50/0.125")-(50/0.125")	* Boring Station and offset are approximate			
35					
40					
45					
50					

Shear Types: ● = Hand Penet. ■ = Torvane ▲ = Unconf. Comp. ✱ = UU Triaxial

PLATE 7b

LOG OF SOIL BORING DG-12-15641 BELTLINE ROAD WITH LAB.GPJ HVJ.GDT 2/5/14

LOG OF BORING

Project: Beltline Road
 Boring No.: B- 5
 Groundwater during drilling: Dry
 Groundwater after drilling: ---

Date: 10/29/2013
 Northing: --
 Easting: --

Project No.: DG-12-15641
 Elevation:
 Appx. Station: 33+18
 Appx. Offset: 12' RT

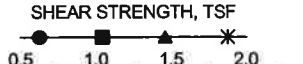
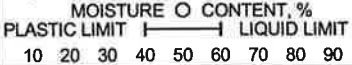
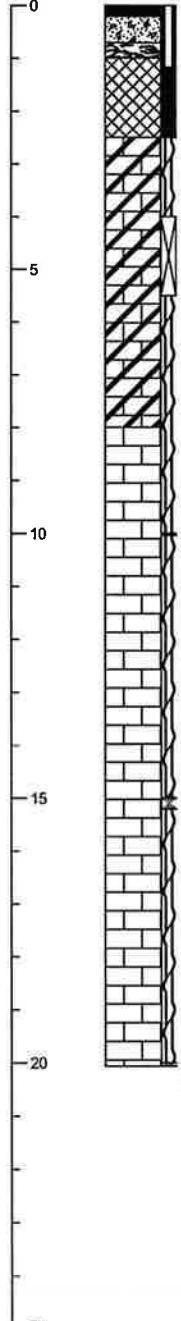
ELEV. DEPTH, FEET	SOIL SYMBOLS SAMPLER SYMBOLS AND FIELD TEST DATA	SOIL/ROCK CLASSIFICATION	% PASSING NO. 200 SIEVE	DRY DENSITY PCF	<div style="text-align: center;"> SHEAR STRENGTH, TSF  </div> <div style="text-align: center;"> MOISTURE CONTENT, % PLASTIC LIMIT LIQUID LIMIT  </div>
<div style="display: flex; align-items: center;"> <div style="margin-right: 10px;">0</div>  </div>	<p>2.5 inches of ASPHALT 6 inches of CONCRETE 3.5 inches of BASE FILL, sandy clay, gravelly, very stiff, brown and gray, with weathered limestone and calcareous deposits</p> <p>LIMESTONE, soft, tan, weathered</p> <p style="text-align: center;">13/6"-11/6"-14/5"</p> <p>LIMESTONE, very hard, gray</p> <p style="text-align: center;">(50/0.25")-(50/0.25")</p> <p style="text-align: center;">(50/1.5")-(50/1")</p> <p style="text-align: center;">(50/0.5")-(50/0.25")</p>	<p>* Boring Station and offset are approximate</p>			<div style="display: flex; justify-content: space-around;"> <div style="text-align: center;">○</div> <div style="text-align: center;">●</div> </div>

Shear Types: ● = Hand Penet. ■ = Torvane ▲ = Unconf. Comp. ✱ = UU Triaxial

LOG OF SOIL BORING, DG-12-15641 BELTLINE ROAD, WITH LAB.GPJ HVJ.GDT, 2/5/14

LOG OF BORING

Project: Beltline Road
 Boring No.: B-6
 Groundwater during drilling: Dry
 Groundwater after drilling: ---

Date: 10/29/2013
 Northing: --
 Easting: --

Project No.: DG-12-15641
 Elevation:
 Appx. Station: 37+18
 Appx. Offset: 6' RT

ELEV. DEPTH, FEET	SOIL SYMBOLS SAMPLER SYMBOLS AND FIELD TEST DATA	SOIL/ROCK CLASSIFICATION	% PASSING NO. 200 SIEVE	DRY DENSITY PCF	<div style="text-align: center;"> SHEAR STRENGTH, TSF </div> <div style="text-align: center;"> MOISTURE CONTENT, % PLASTIC LIMIT LIQUID LIMIT </div>
0		2 inches of ASPHALT 6 inches of CONCRETE 4 inches of BASE FILL, lean clay, stiff to very stiff, brown and gray, with weathered limestone, gravel and calcareous deposits ----- Limestone, hard, tan, weathered, shaley ----- (50/3.25")-(50/0.25") ----- Limestone, very hard, gray ----- (50/0.75")-(50/0.25") ----- (50/1")-(50/0.125") ----- (50/0.25")-(50/0.25")			
5					
10					
15					
20					
25					

Shear Types: ● = Hand Penet. ■ = Torvane ▲ = Unconf. Comp. ✱ = UU Triaxial

* Boring Station and offset are approximate

LOG OF SOIL BORING DG-12-15641 BELTLINE ROAD WITH LAB.GPJ HVJ.GDT 2/5/14

LOG OF BORING

Project: Beltline Road
 Boring No.: B-7
 Groundwater during drilling: Dry
 Groundwater after drilling: ---

Date: 10/29/2013
 Northing: --
 Easting: --

Project No.: DG-12-15641
 Elevation:
 Appx. Station: 43+23
 Appx. Offset: 12' RT

ELEV. DEPTH, FEET	SOIL SYMBOLS SAMPLER SYMBOLS AND FIELD TEST DATA	SOIL/ROCK CLASSIFICATION	% PASSING NO. 200 SIEVE	DRY DENSITY PCF	<div style="text-align: center;"> SHEAR STRENGTH, TSF 0.5 1.0 1.5 2.0 ● ■ ▲ ✱ MOISTURE CONTENT, % PLASTIC LIMIT LIQUID LIMIT 10 20 30 40 50 60 70 80 90 </div>
<div style="display: flex; align-items: center;"> <div style="flex: 1;"> <p>0</p> <p>5</p> <p>10</p> <p>15</p> <p>20</p> <p>25</p> </div> <div style="flex: 1;">  </div> </div>	<p>2 inches of ASPHALT 6.5 inches of CONCRETE 3.5 inches of BASE FILL, sandy clay, gravelly, stiff, brown and gray, with weathered limestone and calcareous deposits</p> <p>-Boring terminated due to unknown hard layer encountered at 4 feet * Boring Station and offset are approximate</p>	<p>2 inches of ASPHALT 6.5 inches of CONCRETE 3.5 inches of BASE FILL, sandy clay, gravelly, stiff, brown and gray, with weathered limestone and calcareous deposits</p>			<div style="display: flex; justify-content: space-around;"> <div style="text-align: center;"> <p>○</p> </div> <div style="text-align: center;"> <p>●</p> </div> </div>

Shear Types: ● = Hand Penet. ■ = Torvane ▲ = Unconf. Comp. ✱ = UU Triaxial

LOG OF SOIL BORING DG-12-15641 BELTLINE ROAD WITH LAB.GPJ HVJ.GDT 2/5/14

LOG OF BORING

Project: Beltline Road
 Boring No.: B- 8
 Groundwater during drilling: Dry
 Groundwater after drilling: ---

Date: 10/31/2013
 Northing: --
 Easting: --

Project No.: DG-12-15641
 Elevation:
 Appx. Station: 48+52
 Appx. Offset: 12' RT

ELEV. DEPTH, FEET	SOIL SYMBOLS SAMPLER SYMBOLS AND FIELD TEST DATA	SOIL/ROCK CLASSIFICATION	% PASSING NO. 200 SIEVE	DRY DENSITY PCF	
<div style="display: flex; align-items: center;"> <div style="margin-right: 10px;"> <p>0</p><p>5</p><p>10</p><p>15</p><p>20</p><p>25</p> </div> </div>	<p>2 inches of ASPHALT 7.5 inches of CONCRETE 2.5 inches of BASE FILL, fat clay, stiff to very stiff, brown and gray, with weathered limestone, gravels, sand and calcareous deposits</p> <p>48/6"-50/5"</p> <p>(50/1")-(50/0.25")</p> <p>(50/1")-(50/0.5")</p> <p>(50/1.25")-(50/0.25")</p>	<p>LIMESTONE, very hard, tan, weathered</p> <p>LIMESTONE, very hard, gray</p>			

* Boring Station and offset are approximate

Shear Types: ● = Hand Penet. ■ = Torvane ▲ = Unconf. Comp. ✱ = UU Triaxial

LOG OF SOIL BORING DG-12-15641 BELTLINE ROAD WITH LAB.GPJ HVJ.GDT 2/5/14





LOG OF BORING

Project: Beltline Road
 Boring No.: B-9
 Groundwater during drilling: Dry
 Groundwater after drilling: ---

Date: 10/29/2013
 Northing: --
 Easting: --

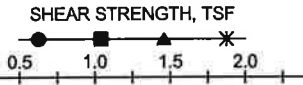
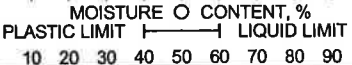
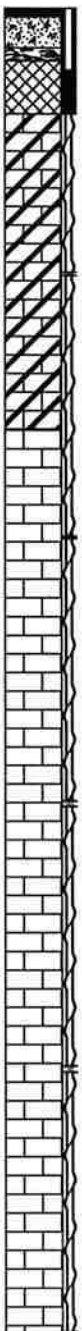
Project No.: DG-12-15641
 Elevation:
 Appx. Station: 53+18
 Appx. Offset: 12' RT

ELEV. DEPTH, FEET	SOIL SYMBOLS SAMPLER SYMBOLS AND FIELD TEST DATA	SOIL/ROCK CLASSIFICATION	% PASSING NO. 200 SIEVE	DRY DENSITY PCF	<div style="text-align: center;"> SHEAR STRENGTH, TSF  MOISTURE CONTENT, % PLASTIC LIMIT LIQUID LIMIT  </div>
0		2 inches of ASPHALT 7 inches of CONCRETE 3 inches of BASE FILL, fat clay, brown and gray, with weathered limestone gravels and calcareous deposits LIMESTONE, very hard, tan, weathered			
5	(50/0.5")-(50/0.25")	LIMESTONE, very hard, gray			
10	(50/0.25")-(50/0.25")				
15	(50/1")-(50/0.25")				
20	(50/0.5")-(50/1")				
25					

* Boring Station and offset are approximate

Shear Types: ● = Hand Penet. ■ = Torvane ▲ = Unconf. Comp. ✱ = UU Triaxial

LOG OF SOIL BORING DG-12-15641 BELTLINE ROAD, WITH LAB.GPJ HVJ.GDT 2/5/14

PLATE 12a

LOG OF BORING

Project: Beltline Road
 Boring No.: B-9
 Groundwater during drilling: Dry
 Groundwater after drilling: ---

Date: 10/29/2013
 Northing: --
 Easting: --

Project No.: DG-12-15641
 Elevation:
 Appx. Station: 53+18
 Appx. Offset: 12' RT

ELEV. DEPTH, FEET	SOIL SYMBOLS SAMPLER SYMBOLS AND FIELD TEST DATA	SOIL/ROCK CLASSIFICATION	% PASSING NO. 200 SIEVE	DRY DENSITY PCF	
<div style="display: flex; align-items: center;"> <div style="margin-right: 10px;"> <p>25</p><p>30</p><p>35</p><p>40</p><p>45</p><p>50</p> </div> </div>	<p>(50/0.25)-(50/0.25)</p> <p>LIMESTONE, very hard, gray</p> <p>(50/1.5)-(50/0.5)</p> <p>* Boring Station and offset are approximate</p>				<div style="text-align: center;"> <p>SHEAR STRENGTH, TSF</p> <p>0.5 1.0 1.5 2.0</p> <hr/> <p>MOISTURE CONTENT, %</p> <p>PLASTIC LIMIT LIQUID LIMIT</p> <p>10 20 30 40 50 60 70 80 90</p> </div>

Shear Types: ● = Hand Penet. ■ = Torvane ▲ = Unconf. Comp. ✱ = UU Triaxial

LOG OF SOIL BORING DG-12-15641 BELTLINE ROAD, WITH LAB.GPJ HVJ.GDT 2/5/14

PLATE 12b

LOG OF BORING

Project: Beltline Road
 Boring No.: B-10
 Groundwater during drilling: Dry
 Groundwater after drilling: ---

Date: 10/31/2013
 Northing: --
 Easting: --

Project No.: DG-12-15641
 Elevation:
 Appx. Station: 58+00
 Appx. Offset: 12' RT

ELEV. DEPTH, FEET	SOIL SYMBOLS SAMPLER SYMBOLS AND FIELD TEST DATA	SOIL/ROCK CLASSIFICATION	% PASSING NO. 200 SIEVE	DRY DENSITY PCF	
<div style="display: flex; align-items: center;"> <div style="margin-right: 10px;">0</div> </div>	<p>2 inches of ASPHALT 7 inches of CONCRETE 3 inches of BASE FILL, fat clay, stiff to very stiff, brown and gray, with weathered limestone, gravels and calcareous deposits</p> <p>50/6"</p> <p>(50/0.25")-(50/0.25")</p> <p>(50/0.5")-(50/0.5")</p> <p>(50/1")-(50/0.5")</p>	<p>LIMESTONE, hard, tan, weathered</p> <p>LIMESTONE, very hard, gray</p>	83	83	<p style="text-align: center;">SHEAR STRENGTH, TSF</p> <p style="text-align: center;">MOISTURE CONTENT, %</p> <p style="text-align: center;">PLASTIC LIMIT LIQUID LIMIT</p>
* Boring Station and offset are approximate					

Shear Types: ● = Hand Penet. ■ = Torvane ▲ = Unconf. Comp. ※ = UU Triaxial

LOG OF SOIL BORING DG-12-15641 BELTLINE ROAD WITH LAB.GPJ HVJ.GDT 2/5/14



SOIL SYMBOLS

Soil Types



Clay



Silt



Sand



Gravel

Modifiers



Clayey



Silty



Sandy



Cemented

Construction Materials



Asphaltic
Concrete



Stabilized
Base



Fill or
Debris



Portland
Cement
Concrete

SAMPLER TYPES

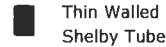

Thin Walled
Shelby Tube



No Recovery



Split Barrel



Auger



Liner Tube



Jar Sample

WATER LEVEL SYMBOLS



Groundwater measured after drilling
operations



Groundwater measured during drilling
operations

SOIL GRAIN SIZE

Classification

Clay
Silt
Sand
Gravel
Cobble
Boulder

Particle Size

< 0.002 mm
0.002 - 0.075 mm
0.075 - 4.75 mm
4.75 - 75 mm
75 - 200 mm
> 200 mm

Particle Size or Sieve No. (U.S. Standard)

< 0.002 mm
0.002 mm - #200 sieve
#200 sieve - #4 sieve
#4 sieve - 3 in.
3 in. - 8 in.
> 8 in.

DENSITY OF COHESIONLESS SOILS

Descriptive Term	Penetration Resistance "N" * Blows/Foot
Very Loose	0 - 4
Loose	4 - 10
Medium Dense	10 - 30
Dense	30 - 50
Very Dense	> 50

CONSISTENCY OF COHESIVE SOILS

Consistency	Undrained Shear Strength (tsf)	Penetration Resistance "N" * (Blows/ft)
Very Soft	0 - 0.125	< 2
Soft	0.125 - 0.25	2-4
Firm	0.25 - 0.5	4-8
Stiff	0.5 - 1.0	8-15
Very Stiff	1.0 - 2.0	15-30
Hard	> 2.0	>30

PENETRATION RESISTANCE

###

Blows required penetrating each of three consecutive 6-inches per ASTM D-1586*

50/4"

If more than 50 blows are required, driving is discontinued and penetration at 50 blows is noted

(4/6")

Texas Cone Penetration blows required penetrating each of two consecutive 6-inches per TEX- 132-E

* The N value is taken as the blows required to penetrate the final 12 inches

TERMS DESCRIBING SOIL STRUCTURE

Slickensided

Fracture planes appear polished or glossy, sometimes striated

Fissured

Breaks along definite planes of fracture with little resistance to fracturing

Inclusion

Small pockets of different soils, such as small lenses of sand scattered through a mass of clay

Parting

Inclusion less than 1/4 inch thick extending through the sample

Seam

Inclusion 1/4 inch to 3 inches thick extending through the sample

Layer

Inclusion greater than 3 inches thick extending through the sample

Laminated

Soil sample composed of alternating partings of different soil type

Stratified

Soil sample composed of alternating seams or layers of different soil type

Intermixed

Soil sample composed of pockets of different soil type and laminated or stratified structure is not evident

Calcareous

Having appreciable quantities of calcium carbonate

Ferrous

Having appreciable quantities of iron

Nodule

A small mass of irregular shape



8701 John Carpenter Fwy Suite 250
Dallas, TX 75247
214-678-0227 Ph
214-678-0228 Fax

KEY TO TERMS AND SYMBOLS USED ON BORING LOGS

PROJECT NO.:

DG-12-15641

DRAWING NO.:

PLATE 14A

ROCK TYPES

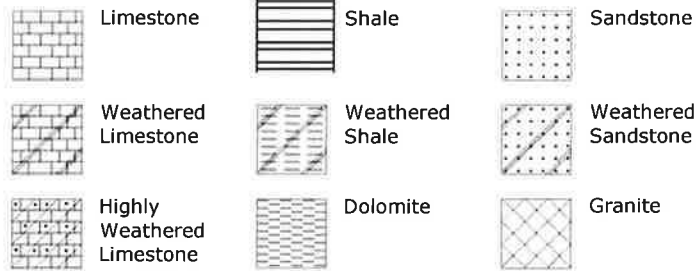

SAMPLER TYPES

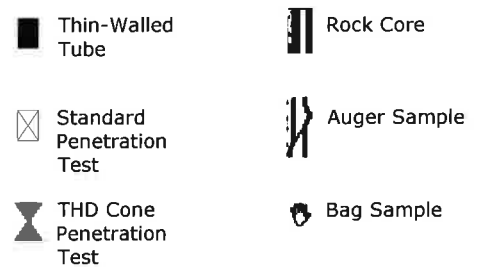

SOLUTION AND VOID CONDITIONS

Void	Interstice; a general term for pore space or other openings in rock.
Cavities	Small solutional concavities.
Vuggy	Containing small cavities, usually lined with a mineral of different composition from that of the surrounding rock.
Vesicular	Containing numerous small, unlined cavities, formed by expansion of gas bubbles or steam during solidification of the rock.
Porous	Containing pores, interstices, or other openings which may or may not interconnect.
Cavernous	Containing cavities or caverns, sometimes quite large. Most frequent in limestones and dolomites.

HARDNESS

Very Soft	Can be carved with a knife, broken with finger pressure, or UCS less than 30 tsf
Soft	Can be gouged or grooved readily with a knife, or UCS between 30 and 100 tsf
Moderately Hard	Can be scratched easily with a knife, or UCS between 100 and 250 tsf
Hard	Can be scratched rarely with a knife, or UCS greater than 250 tsf
Very Hard	Cannot be scratched with a knife

WEATHERING GRADES OF ROCKMASS ⁽¹⁾

Slightly	Discoloration indicates weathering of rock material and discontinuity surfaces.
Moderately	Less than half of the rock material is decomposed or disintegrated to a soil.
Highly	More than half of the rock material is decomposed or disintegrated to a soil.
Completely	All rock material is decomposed and/or disintegrated into soil. The original mass structure is still largely intact.
Residual Soil	All rock material is converted to soil. The mass structure and material fabric are destroyed.

JOINT DESCRIPTION

SPACING		INCLINATION		SURFACES	
Very Close	<2"	Horizontal	0-5	Slickensided	Polished, grooved
Close	2"-12"	Shallow	5-35	Smooth	Planar
Medium Close	12"-3'	Moderate	35-65	Irregular	Undulating or granular
Wide	>3'	Steep	65-85	Rough	Jagged or pitted
		Vertical	85-90		

REFERENCES:

(1) British Standard (1981) Code of Practice for Site Investigation, BS 5930.

(2) The Bridge Div., Tx. Highway Dept. Foundation Exploration & Design Manual, 2nd Division, revised June, 1974.

BEDDING THICKNESS ⁽²⁾

Very Thick	>4'
Thick	2'-4'
Thin	2"-2'
Very Thin	1/2"-2"
Laminated	0.08"-1/2"
Thinly Laminated	<0.08"

Information on each boring log is a compilation of subsurface conditions and soil and rock classifications obtained from the field as well as from laboratory testing of samples. Strata have been interpreted by commonly accepted procedures. The stratum lines on the logs may be transitional and approximate in nature. Water level measurements refer only to those observed at the times and places indicated, and may vary with time, geologic condition or construction activity.



8701 John Carpenter Fwy Suite 250
Dallas, TX 75247
214-678-0227 Ph
214-678-0228 Fax

KEY TO TERMS AND SYMBOLS USED ON BORING LOGS

PROJECT NO.: DG-12-15641

DRAWING NO.: PLATE 14B

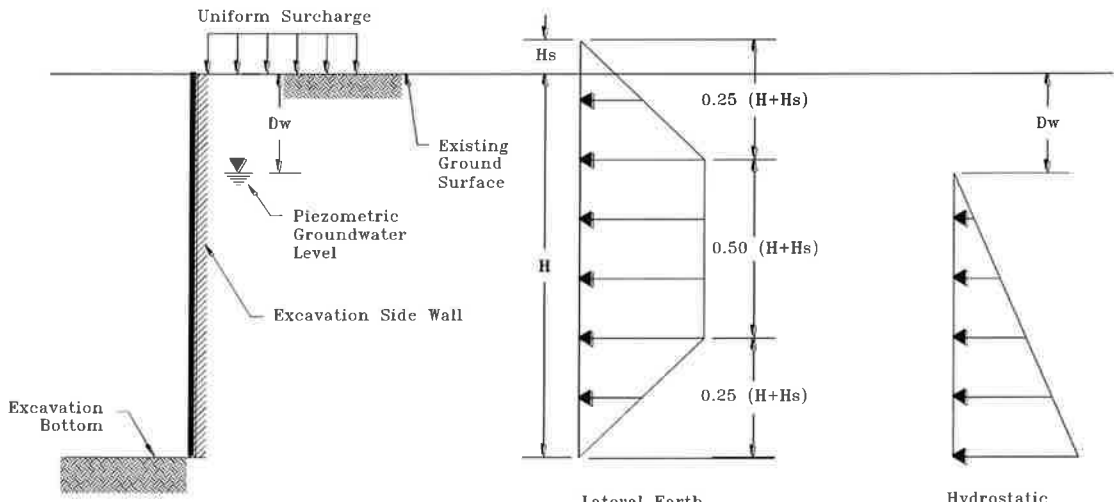

Lateral Earth Pressure, P
 $P = K \gamma (H+H_s)$

Hydrostatic Water Pressure, Pw
 $P_w = \gamma_w (H-D_w)$

H, (ft) = Depth to Excavation Bottom
 S, (psf) = Surcharge loading adjacent to Excavation wall
 D_w, (ft) = Depth to groundwater below Existing grade
 = Zero for temporary excavation
 H_s, (ft) = Equivalent Depth of surcharge loading
 $H_s = \frac{S}{120}$

K = Lateral Earth Pressure coefficient
 (Clay - 0.5 for short term (K_a), 1.0 for long term condition (K_o)
 (Sand - 0.3 for short term (K_a), 0.5 for long term condition (K_o))
 γ , (pcf) = Total unit weight above water table or submerged unit weight below groundwater level
 γ_w , (pcf) = Unit weight of water = 62.4 pcf

Note: The pressure diagram shown is not appropriate for design of cantilever walls.

 8701 Jaker Carpenter Pkwy Suite 250 Dallas, TX 75249 214 478-0022 Ph 214 478-0238 Fax		
DATE: 12/03/2013	APPROVED BY: JP	PREPARED BY: SS
BRACED EXCAVATION LATERAL EARTH PRESSURE DIAGRAM		
PROJECT NO.: DG-12-15641	DRAWING NO.: PLATE 15	

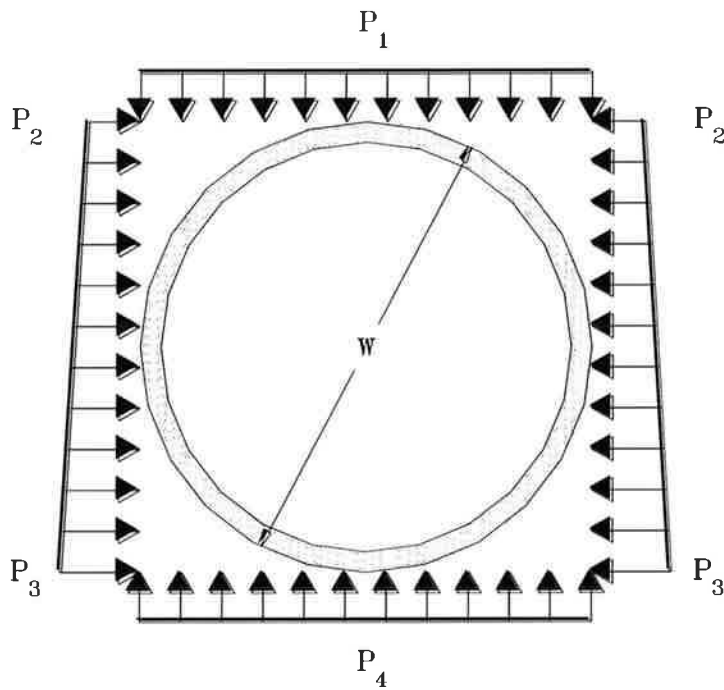

For

$$D_w \leq H$$

$$P_1 = \gamma D_w + (H - D_w)(\gamma - \gamma_w) + P_s + (H - D_w)\gamma_w$$

$$P_2 = [\gamma D_w + (H - D_w)(\gamma - \gamma_w) + P_s]K_o + (H - D_w)\gamma_w$$

$$P_3 = [\gamma D_w + (H + W - D_w)(\gamma - \gamma_w) + P_s]K_o + (H + W - D_w)\gamma_w$$

$$P_4 = \gamma D_w + (H + W - D_w)(\gamma - \gamma_w) + P_s + (H + W - D_w)\gamma_w$$

For

$$H < D_w < H + W$$

$$P_1 = H\gamma + P_s$$

$$P_2 = (\gamma H + P_s)K_o$$

$$P_3 = [\gamma D_w + (H + W - D_w)(\gamma - \gamma_w) + P_s]K_o + (H + W - D_w)\gamma_w$$

$$P_4 = \gamma D_w + (H + W - D_w)(\gamma - \gamma_w) + P_s + (H + W - D_w)\gamma_w$$

For

$$D_w \geq (H + W)$$

$$P_1 = H\gamma + P_s$$

$$P_2 = (\gamma H + P_s)K_o$$

$$P_3 = [(H + W)\gamma + P_s]K_o$$

$$P_4 = (H + W)\gamma + P_s$$

Where

P_1, P_2, P_3 = Pressure imposed on pipe, psf

D_w = Depth of groundwater, feet

H = Depth of top of pipe from ground surface, feet

W = Diameter of pipe, feet

γ = Total Unit weight of soil, pcf

γ_w = Unit weight of water, pcf

P_s = Surcharge load, psf

K_o = Coefficient of earth pressure, (1.0 for clays and 0.5 for sands)



8701 John Carpenter Fwy Suite 250
Dallas, TX 75247
214-678-0227 Ph
214-678-0228 Fax

DATE: 12/03/2013

APPROVED BY:
JP

PREPARED BY:
SS

RIGID PIPE LOADS

PROJECT NO.:
DG-12-15641

DRAWING NO.:
PLATE 16

APPENDIX A
SUMMARY OF LABORATORY TESTING RESULTS

Boring#	Depth	Liquid Limit	Plastic Limit	PI	Percent Finer Than #200 Sieve	Moisture Content (%)	Wet Unit Weight (pcf)	Shear Strength (UC) (tsf)	Pocket Pen (tsf)
B- 1	1.5				30	19			
B- 1	4								1.5
B- 1	5	46	17	29		14	118	0.74	
B- 1	6								1.5
B- 1	9				80	18			
B- 2	1.2								1.5
B- 2	2								0.67
B- 2	3				90	30			
B- 2	4								0.58
B- 2	6								0.5
B- 2	7	46	19	27	72	23	124.5	0.37	
B- 2	9				45	21			
B- 2	13								1.5
B- 2	14	54	24	30	80	17			
B- 3	1.2								1.5
B- 3	1.5				88	26			
B- 3	2								1.33
B- 3	4								1.5
B- 3	5	57	24	33		21	123.7	0.81	
B- 3	9	39	22	17		19			
B- 4	1.2								1.5
B- 4	1.5				90	20			
B- 4	2								1.5
B- 4	3	63	21	42		33	118.8	1.28	
B- 4	4								1.5



8701 John Carpenter Fwy Suite 250
 Dallas, TX 75247
 214-678-0227 Ph
 214-678-0228 Fax

DATE: 11/26/2013

APPROVED BY:
JP

PREPARED BY:
SS

SUMMARY OF LAB TEST RESULTS
 BELTLINE ROAD
 From Marsh Lane To Midway Road

PROJECT NO.: DG-12-15641

DRAWING NO.: A-1

Boring#	Depth	Liquid Limit	Plastic Limit	PI	Percent Finer Than #200 Sieve	Moisture Content (%)	Wet Unit Weight (pcf)	Shear Strength (UC) (tsf)	Pocket Pen (tsf)
B- 5	1.2								1.5
B- 5	1.5					22			
B- 6	1.2								1
B- 6	1.5					35			
B- 6	2								1
B- 6	3	48	20	28		19			
B- 7	1.2								0.83
B- 7	1.5					25			
B- 7	2								0.83
B- 8	1.2								0.83
B- 8	1.5					24			
B- 8	2								0.83
B- 8	3	60	34	26		16			
B- 8	4								1.5
B- 8	5					22			
B- 8	7					18			
B- 9	1.5	60	29	31		35			
B-10	1.2								1
B-10	1.5					34			
B-10	2								1
B-10	3	74	35	39		32	109	0.9	
B-10	4								1.5
Total		10	10	10	8	23	5	5	24



8701 John Carpenter Fwy Suite 250
 Dallas, TX 75247
 214-678-0227 Ph
 214-678-0228 Fax

DATE: 11/26/2013

APPROVED BY:
JP

PREPARED BY:
SS

SUMMARY OF LAB TEST RESULTS
 BELTLINE ROAD
 From Marsh Lane To Midway Road

PROJECT NO.: DG-12-15641

DRAWING NO.:
A-2

APPENDIX B

PAVEMENT CORE PICTURES

**Beltline Road
From Marsh Lane to Midway Road
Town of Addison**

Geotech Points			Pavement Thickness (inches)	
Core #	Station	Offset (RT)	Asphalt	Concrete
B-1	12+80	15'	2	6.5
C-1	16+10	10'	2	7
B-2	18+00	6'	2	5.5
C-2	20+45	15'	2	7.5
B-3	22+30	9'	2	7
C-3	25+12	18'	2	9
B-4	28+30	6'	2	7
C-4	30+81	12'	2	8
B-5	33+18	12'	2.5	6
C-5	35+36	3'	2	6.5
B-6	37+18	6'	2	6
C-6	39+70	12'	2	5.5
B-7	43+23	12'	2	6.5
C-7	45+48	3'	2	5.5
B-8	48+52	12'	2	7
C-8	50+66	3'	2	7.5
B-9	53+18	12'	2	7
C-9	55+70	3'	2	5
B-10	58+00	12'	2	7
C-10	60+30	0'	3	6

Note: Asphalt pavement is overlaid on top of Concrete pavement



			<small>8701 John Carpenter Fwy Suite 250 Dallas, TX 75237 214 678 0237 Pk 214 678 0228 Fax</small>		
DATE: 11/6/13		APPROVED BY: JP		PREPARED BY: RE	
ROADWAY CORE #B-1 and C-1 BELTLINE ROAD From Marsh Lane To Midway Road					
PROJECT NO.: DG-12-15641			DRAWING NO.: B-1		



			<small>8701 John Carpenter Fwy Suite 250 Dallas, TX 75247 214-678-0227 (H) 214-678-0228 Fax</small>		
DATE: 11/6/13		APPROVED BY: JP		PREPARED BY: RE	
ROADWAY CORE #B-2 and C-2 BELTLINE ROAD From Marsh Lane To Midway Road					
PROJECT NO.: DG-12-15641			DRAWING NO.: B-2		



8701 John Carpenter Pkwy Suite 250
Dallas, TX 75247
214-678-0237 Ph
214-678-0238 Fax

DATE: 11/6/13

APPROVED BY: JP

PREPARED BY: RE

ROADWAY CORE #B-3 and C-3
BELTLINE ROAD
From Marsh Lane To Midway Road

PROJECT NO.: DG-12-15641

DRAWING NO.: B-3



8701 John Carpenter Pkwy Suite 250
 Dallas, TX 75247
 214 678-0227 Pk
 214 678-0228 Fax

DATE: 11/6/13

APPROVED BY: JP

PREPARED BY: RE

ROADWAY CORE #B-4 and C-4
 BELTLINE ROAD
 From Marsh Lane To Midway Road

PROJECT NO.: DG-12-15641

DRAWING NO.: B-4



8701 John Carpenter Fwy Suite 250
Dallas, TX 75247
214-678-0227 Ph
214-678-0228 Fax

DATE: 11/6/13	APPROVED BY: JP	PREPARED BY: RE
ROADWAY CORE #B-5 and C-5 BELTLINE ROAD From Marsh Lane To Midway Road		
PROJECT NO.: DG-12-15641	DRAWING NO.: B-5	



8701 John Carpenter Fwy Suite 250
Dallas, TX 75247
214-678-0227 Pl.
214-678-0328 Fax

DATE: 11/6/13

APPROVED BY: JP

PREPARED BY: RE

ROADWAY CORE #B-6 and C-6
BELTLINE ROAD
From Marsh Lane To Midway Road

PROJECT NO.: DG-12-15641

DRAWING NO.: B-6



8701 John Carpenter Frey Suite 200
 Dallas, TX 75247
 214-678-0227 Ph
 214-678-0238 Fax

DATE: 11/6/13

APPROVED BY: JP

PREPARED BY: RE

ROADWAY CORE #B-7 and C-7
 BELTLINE ROAD
 From Marsh Lane To Midway Road

PROJECT NO.: DG-12-15641

DRAWING NO.: B-7



			<small>8701 John Carpenter Pkwy Suite 250 Dallas, TX 75247 214 476 0227 Pkx 214 476 0228 Fax</small>		
DATE: 11/6/13		APPROVED BY: JP		PREPARED BY: RE	
ROADWAY CORE #B-8 and C-8 BELTLINE ROAD From Marsh Lane To Midway Road					
PROJECT NO.: DG-12-15641			DRAWING NO.: B-8		



8701 John Carpenter Pkwy Suite 250
Dallas, TX 75247
214.678.0227 Ph.
214.678.0238 Fax

DATE: 11/6/13

APPROVED BY: JP

PREPARED BY: RE

ROADWAY CORE #B-9 and C-9

BELTLINE ROAD

From Marsh Lane To Midway Road

PROJECT NO.: DG-12-15641

DRAWING NO.: B-9



8701 John Carpenter Fwy Suite 250
 Dallas, TX 75247
 214-678-0227 8%
 214-678-0238 Fax

DATE: 11/6/13

APPROVED BY: JP

PREPARED BY: RE

ROADWAY CORE #B-10 and C-10
 BELTLINE ROAD
 From Marsh Lane To Midway Road

PROJECT NO.: DG-12-15641

DRAWING NO.: B-10

APPENDIX C

SULFATE TEST RESULTS



November 25, 2013

Russell Sieg
HVJ Associates, Inc.
4201 Freidrich Lane, Suite 110
Austin, Texas 78744-1045

TEL: (512) 447-9081

FAX (512) 443-3442

RE: Belt Line Rd

Order No.: 1311165

Dear Russell Sieg:

DHL Analytical, Inc. received 3 sample(s) on 11/18/2013 for the analyses presented in the following report.

There were no problems with the analyses and all data for associated QC met EPA or laboratory specifications except where noted in the Case Narrative and all estimated uncertainties of results are within method specifications.

If you have any questions regarding these tests results, please feel free to call.

Sincerely,

A handwritten signature in black ink, appearing to read 'John DuPont', is written over a light gray background.

John DuPont
General Manager

This report was performed under the accreditation of the State of Texas Laboratory Certification Number: T104704211-13-11



Table of Contents

Miscellaneous Documents	3
CaseNarrative 1311165	5
Analytical Report 1311165	6
AnalyticalQCSummaryReport 1311165	9



2300 Double Creek Dr. ■ Round Rock, TX 78664
 Phone (512) 388-8222 ■ FAX (512) 388-8229
 Web: www.dhlanalytical.com
 E-Mail: login@dhlanalytical.com



No. _____
CHAIN-OF-CUSTODY

CLIENT: HVS Associates, Inc.
 ADDRESS: 4201 Friedrich Ln, Ste. 110
 PHONE: 512-903-8143 FAX/E-MAIL: rsieg@hvj.com
 DATA REPORTED TO: Russell Sieg
 ADDITIONAL REPORT COPIES TO: _____

DATE: 11/18/2013 PAGE 1 OF 1
 PO #: 13-0949 DHL WORK ORDER #: 131165
 PROJECT LOCATION OR NAME: Belt Line Rd
 CLIENT PROJECT #: DG-12-15641 COLLECTOR: _____

Field Sample I.D.	DHL Lab #	Date	Time	Matrix	Container Type	# of Containers	PRESERVATION				ANALYSES	FIELD NOTES
							HCl	HNO ₃	H ₂ SO ₄	NaOH		
B-2, 2'-4'	01	11/18/13										dark brown
B-6, 1'-2'	02											dark brown
B-8, 2'-4'	03											brown

TOTAL: _____

RELINQUISHED BY: (Signature) <u>Russell Sieg</u>	DATE/TIME <u>11/18/13 1449</u>	RECEIVED BY: (Signature) <u>[Signature]</u>	TURN AROUND TIME RUSH <input type="checkbox"/> CALL FIRST 1 DAY <input type="checkbox"/> CALL FIRST 2 DAY <input type="checkbox"/> NORMAL <input checked="" type="checkbox"/> OTHER <input type="checkbox"/>	LABORATORY USE ONLY: RECEIVING TEMP: <u>26.9</u> THERM #: <u>57</u> CUSTODY SEALS: <input type="checkbox"/> BROKEN <input type="checkbox"/> INTACT <input checked="" type="checkbox"/> NOT USED <input type="checkbox"/> CARRIER BILL #: <input type="checkbox"/> APC DELIVERY <input type="checkbox"/> HAND DELIVERED
RELINQUISHED BY: (Signature)	DATE/TIME	RECEIVED BY: (Signature)		
RELINQUISHED BY: (Signature)	DATE/TIME	RECEIVED BY: (Signature)		

DHL DISPOSAL @ \$5.00 each Return

DHL Analytical, Inc.

Sample Receipt Checklist

Client Name HVJ Associates, Inc.
Work Order Number 1311165

Date Received: 11/18/2013
Received by JB

Checklist completed by: [Signature] 11/18/2013
Signature Date

Reviewed by: [Initials] 11/18/2013
Initials Date

Carrier name Hand Delivered

- Shipping container/cooler in good condition? Yes No Not Present
- Custody seals intact on shipping container/cooler? Yes No Not Present
- Custody seals intact on sample bottles? Yes No Not Present
- Chain of custody present? Yes No
- Chain of custody signed when relinquished and received? Yes No
- Chain of custody agrees with sample labels? Yes No
- Samples in proper container/bottle? Yes No
- Sample containers intact? Yes No
- Sufficient sample volume for indicated test? Yes No
- All samples received within holding time? Yes No
- Container/Temp Blank temperature in compliance? Yes No 26.9 °C
- Water - VOA vials have zero headspace? Yes No No VOA vials submitted
- Water - pH<2 acceptable upon receipt? Yes No NA LOT #
Adjusted? _____ Checked by _____
- Water - pH>9 (S) or pH>12 (CN) acceptable upon receipt? Yes No NA LOT #
Adjusted? _____ Checked by _____

Any No response must be detailed in the comments section below.

Client contacted _____ Date contacted: _____ Person contacted _____

Contacted by: _____ Regarding _____

Comments: _____

Corrective Action _____

CLIENT: HVJ Associates, Inc.
Project: Belt Line Rd
Lab Order: 1311165

CASE NARRATIVE

Samples were analyzed using the methods outlined in the following references:

Sulfate Content in Soil by method TEX620J.

All method blanks, sample duplicates, laboratory spikes, and/or matrix spikes met quality assurance objectives.

DHL Analytical, Inc.

Date: 25-Nov-13

CLIENT: HVJ Associates, Inc.
Project: Belt Line Rd
Project No: DG-12-15641
Lab Order: 1311165

Client Sample ID: B-2 2-4'
Lab ID: 1311165-01
Collection Date: 11/08/13
Matrix: SOIL

Analyses	Result	MDL	RL	Qual	Units	DF	Date Analyzed
CHLORIDE AND SULFATE CONTENT IN SOIL		TEX620J					Analyst: JBC
Sulfate	446	2.00	5.00	N	ppm-dry	1	11/22/13 10:33 AM

Qualifiers:	* Value exceeds TCLP Maximum Concentration Level	B Analyte detected in the associated Method Blank
	C Sample Result or QC discussed in the Case Narrative	DF Dilution Factor
	E TPH pattern not Gas or Diesel Range Pattern	J Analyte detected between MDL and RL
	MDL Method Detection Limit	ND Not Detected at the Method Detection Limit
	RL Reporting Limit	S Spike Recovery outside control limits
	N Parameter not NELAC certified	

DHL Analytical, Inc.

Date: 25-Nov-13

CLIENT: HVJ Associates, Inc.
Project: Belt Line Rd
Project No: DG-12-15641
Lab Order: 1311165

Client Sample ID: B-6 1-2'
Lab ID: 1311165-02
Collection Date: 11/08/13
Matrix: SOIL

Analyses	Result	MDL	RL	Qual	Units	DF	Date Analyzed
CHLORIDE AND SULFATE CONTENT IN SOIL							Analyst: JBC
Sulfate	146	1.99	4.97	N	ppm-dry	1	11/22/13 10:47 AM

Qualifiers:	* Value exceeds TCLP Maximum Concentration Level	B Analyte detected in the associated Method Blank
	C Sample Result or QC discussed in the Case Narrative	DF Dilution Factor
	E TPH pattern not Gas or Diesel Range Pattern	J Analyte detected between MDL and RL
	MDL Method Detection Limit	ND Not Detected at the Method Detection Limit
	RL Reporting Limit	S Spike Recovery outside control limits
	N Parameter not NELAC certified	

DHL Analytical, Inc.

Date: 25-Nov-13

CLIENT: HVJ Associates, Inc.
Project: Belt Line Rd
Project No: DG-12-15641
Lab Order: 1311165

Client Sample ID: B-8 2-4'
Lab ID: 1311165-03
Collection Date: 11/08/13
Matrix: SOIL

Analyses	Result	MDL	RL	Qual	Units	DF	Date Analyzed
CHLORIDE AND SULFATE CONTENT IN SOIL							Analyst: JBC
Sulfate	146	1.99	4.97	N	ppm-dry	1	11/22/13 11:02 AM

Qualifiers:	* Value exceeds TCLP Maximum Concentration Level	B Analyte detected in the associated Method Blank
	C Sample Result or QC discussed in the Case Narrative	DF Dilution Factor
	E TPH pattern not Gas or Diesel Range Pattern	J Analyte detected between MDL and RL
	MDL Method Detection Limit	ND Not Detected at the Method Detection Limit
	RL Reporting Limit	S Spike Recovery outside control limits
	N Parameter not NELAC certified	

CLIENT: HVJ Associates, Inc.
Work Order: 1311165
Project: Belt Line Rd

ANALYTICAL QC SUMMARY REPORT

RunID: IC2_131122A

The QC data in batch 60618 applies to the following samples: 1311165-01A, 1311165-02A, 1311165-03A

Sample ID: LCS-60618	Batch ID: 60618	TestNo: Tex620J	Units: ppm-dry
SampType: LCS	Run ID: IC2_131122A	Analysis Date: 11/22/2013 9:04:39 AM	Prep Date: 11/21/2013

Analyte	Result	RL	SPK value	Ref Val	%REC	LowLimit	HighLimit	%RPD	RPDLimit	Qual
Sulfate	206	5.00	200.0	0	103	80	120			N

Sample ID: LCSD-60618	Batch ID: 60618	TestNo: Tex620J	Units: ppm-dry
SampType: LCSD	Run ID: IC2_131122A	Analysis Date: 11/22/2013 9:19:13 AM	Prep Date: 11/21/2013

Analyte	Result	RL	SPK value	Ref Val	%REC	LowLimit	HighLimit	%RPD	RPDLimit	Qual
Sulfate	208	5.00	200.0	0	104	80	120	1.16	20	N

Sample ID: MB-60618	Batch ID: 60618	TestNo: Tex620J	Units: ppm-dry
SampType: MBLK	Run ID: IC2_131122A	Analysis Date: 11/22/2013 9:33:48 AM	Prep Date: 11/21/2013

Analyte	Result	RL	SPK value	Ref Val	%REC	LowLimit	HighLimit	%RPD	RPDLimit	Qual
Sulfate	ND	5.00								N

Sample ID: 1311164-01A DUP	Batch ID: 60618	TestNo: Tex620J	Units: ppm-dry
SampType: DUP	Run ID: IC2_131122A	Analysis Date: 11/22/2013 10:03:59 A	Prep Date: 11/21/2013

Analyte	Result	RL	SPK value	Ref Val	%REC	LowLimit	HighLimit	%RPD	RPDLimit	Qual
Sulfate	107	4.96	0	102.5				3.98	25	N

- Qualifiers:**
- B Analyte detected in the associated Method Blank
 - J Analyte detected between MDL and RL
 - ND Not Detected at the Method Detection Limit
 - RL Reporting Limit
 - J Analyte detected between SDL and RL
 - DF Dilution Factor
 - MDL Method Detection Limit
 - R RPD outside accepted control limits
 - S Spike Recovery outside control limits
 - N Parameter not NELAC certified